

IMPROVING LIVES WITH  
PRECISION DIAGNOSTICS®

2020 PRODUCT CATALOG

25TH ANNIVERSARY EDITION

 **invivoscribe**®



CELEBRATING  
25 YEARS

IMPROVING LIVES WITH  
PRECISION DIAGNOSTICS®



## DEAR COLLEAGUES:

I am pleased to introduce Invivoscribe's 2020 Product Catalog. I'll take this opportunity to share some of last year's accomplishments.

Total year over year revenue grew over 30%, supported by new tests, menu items, adoption of our suite of LymphoTrack® assays that include bioinformatics software, and our LeukoStrat® FLT3 CDx Mutation Assay.

Invivoscribe (IVS) received several regulatory approvals for the internationally-standardized FLT3 signal ratio test, including approval of the CDx claim for quizartinib in Japan. We submitted a CDx distributable kit package to the US FDA so we anticipate we will be able to sell a FLT3 CDx kit in the US later this year. We also finalized several new CDx partnership projects: one for a new CDx assay on the 7500 Fast Dx instrument, and one with a previous partner. We will announce these deals early in 2020.

IVS participated in over 30 conferences and tradeshows worldwide, presenting 8 posters and publishing 2 scientific papers with participation from our R&D, LabPMM and bioinformatics groups. A number of scientific papers and posters were also published or presented by customers using our products.

IVS launched MRD controls for both B- and T-cell assays with our comprehensive suite of LymphoTrack Clonality Assays, including LymphoTrack® software for Illumina® NGS platforms. These assays identify and track clonal rearrangements within the antigen receptor loci (*IGH*, *IGK*, *TRG*, *TRB*). The 24 ID format (48 indices for the *IGH* FR1 assay) allows customers to significantly reduce costs, as users can run any combination of the 7 assays (up to 178 samples with 14 controls) simultaneously on one chip, as the accompanying bioinformatics software automatically sorts and interprets the data for each targeted region and sequence ID. These RUO assays are being used with accompanying minimal residual disease (MRD) bioinformatics software in international studies of a wide range of hematologic malignancies, including multiple myeloma and acute lymphoblastic leukemia. The assays will be submitted for review via the US FDA's 510(k) process and with the appropriate regulatory authorities worldwide.

We also finished development of a *TRG* MiSeqDx 510(k) assay; released LymphoTrack® Dx assays for ThermoFisher NGS platforms, and started working under an exclusive agreement with the BIOMED-2 /EuroClonality Consortium in Europe to develop and commercialize their NGS-based assays.

In addition, we made substantial progress building out a new wet lab in Shanghai to add further capabilities for clinical programs to support our pharma partners in China, expanded operations and capabilities at our clinical labs in the US, Japan, the EU, and established an entirely new line of business: setting up a flow cytometry lab so we can soon offer both flow- and NGS-based MRD testing intramurally on exactly the same primary specimens.

We developed a number of engineered cell lines using CRISPR technology, a highly sensitive assay on a digital droplet PCR platform, and filed a number of patents. Still further, we launched a wholly-owned drug development company, Invivoscribe Therapeutics, that has already started testing a small molecule that targets myeloid malignancies.

In 2019 our entire range of tests, including MyAML®, and MyMRD® gene panels with our MyInformatics® bioinformatics pipeline, received increased traction and use by more than three dozen pharmaceutical partners. These tests are available as RUO and/or CLIA/CAP-listed tests through our LabPMM clinical laboratories in the USA, Europe, and Asia.

Finally, I want to acknowledge that our continued growth and progress over these past 25 years would not be possible without our customer's feedback and support. We look forward to continued interaction with the research and clinical communities so we can offer you the best products for decades to come and we wish you, your colleagues, and your families a joyful, productive, and successful 2020.

*Sincerely Yours,*

**Jeffrey Edward Miller, Ph.D.**

*Founder, Chief Scientific Officer,  
Chief Executive Officer & Chairman*



# INVIVOSCRIBE BOARD OF DIRECTORS



## **Hardwick Simmons, MBA**

Hardwick 'Wick' Simmons retired as the Chairman and CEO of The Nasdaq Stock Market, Inc. in May of 2003. Prior to Nasdaq, he served as President and CEO of Prudential Securities Inc., a major investment management and securities brokerage firm. Simmons is a former chairman of the Securities Industry Association, a former director of the Chicago Board Options Exchange and a former president of the New York Bond Club. He is currently a director of Lionsgate Entertainment Corp., president of Stonetex Oil Corp., and a trustee of Woods Hole Oceanographic Institution. He is a graduate of Harvard College and Harvard Business School and served in the U.S. Marine Corps Reserve from 1960 until 1966.



## **Mitchell Kronenberg, Ph.D.**

Mitchell Kronenberg received a B.A. from Columbia University, a Ph.D. from the California Institute of Technology, and served on the faculty of the UCLA School of Medicine from 1986-1997. He joined the La Jolla Institute for Immunology in 1997, and has been the President there since 2003. The Institute has grown in accomplishment and reputation under his leadership. Dr. Kronenberg's research interests include natural killer T cells, other innate lymphocytes such as MAIT cells and ILC, regulation of mucosal immunology and the microbiome and pathogenesis of inflammatory bowel disease. He has co-authored more than 350 publications, and is a fellow of the American Association for the Advancement of Science (AAAS), a Distinguished Fellow of the American Association of Immunologists, recipient of an NIH MERIT award and is an Institute for Scientific Information (ISI) Highly Cited Scientist. In 2016, he was named the most admired CEO (large nonprofit organization category) by the San Diego Business Journal. He is an advisor to a number of organizations including service as a member of the Board of Scientific Counselors for Basic Science, National Cancer Institute and he has been involved with Invivoscribe since its founding.



## **Stephen Wilson, Ph.D.**

Dr. Wilson is a biomedical research executive with more than two decades of experience in basic and translational immunology. He received his B.S.A. and Ph.D. from the University of Arizona, and serves as the Executive Vice President and Chief Operating Officer of the La Jolla Institute for Immunology.



## Jeffrey Edward Miller, Ph.D.

Dr. Miller is a scientist, inventor, and entrepreneur focused on Improving Lives with Precision Diagnostics® – coupling drug trials and therapeutic treatment regimens with optimized clinically-actionable diagnostic methods in order to select the correct patients and then monitor and track their response throughout the course of their disease. He received his undergraduate degree in Biochemistry from UCLA and a combined Ph.D. in Biochemistry & Molecular Biology from UCSB. Prior to starting Invivoscribe, Dr. Miller had more than twenty years of combined experience in protein biochemistry, cellular and molecular immunology, cardiac physiology, virology, and molecular biology, experience he had developed working in laboratories at the Medical School, Department of Chemistry, Molecular Biology Institute at UCLA, while earning his Ph.D. at UCSB, and as a postdoctoral scientist at Applied Molecular Evolution. He also spent several years at Quest Diagnostics Nichols Institute, setting up the molecular oncology laboratory and developing and launching PCR-based molecular assays for infectious disease and hematopathology.



## James Isaacs, Jr., J.D.

James B. Isaacs, Jr. has practiced law since 1983. He currently serves as Licensing and Contracts Counsel at Invivoscribe. Jim attended Stanford University and Yale Law School, then began his career at the Los Angeles law firm of O'Melveny & Myers. As a trial lawyer and later in-house counsel with a focus on intellectual property disputes, Jim has successfully defended a myriad of businesses and individuals; in plaintiffs' actions he has obtained and collected multi-million dollar judgments in the United States and abroad. As a businessman and co-founder of Invivoscribe, Jim has been active in the legal and commercial affairs of the company since 1995.



## Gary Clouse, J.D.

Gary Clouse has practiced as a litigator and business attorney in Southern California for more than three decades. He currently serves as Corporate Secretary and Legal Counsel for Special Projects at Invivoscribe. Clouse is a graduate of Indiana State University and Northwestern University School of Law. Following law school, he clerked for the federal Seventh Circuit Court of Appeals in Chicago. He began his legal practice at the law firm O'Melveny & Myers in Los Angeles. Clouse is one of the founders of invivoscribe.



## Improving the quality of healthcare worldwide.

Committed to providing high quality, reliable, cutting-edge tools for molecular diagnostic and personalized molecular medicine.

# EXECUTIVE LEADERSHIP TEAM



Meghna Bhatnagar

## **Meghna Bhatnagar, MBA, Chief Financial Officer**

Meghna Bhatnagar joined Invivoscribe in 2010 as Chief Financial Officer. In this role she is responsible for leading the Invivoscribe global finance organization, along with human resources and information technology. Since her arrival, Ms. Bhatnagar has played an integral role in directing all aspects of company strategy, planning and operations.

Ms. Bhatnagar has over 20 years of experience building and leading finance and IT teams in global companies. Prior to joining IVS, she served as COO of Radiant Technologies, a technology company focused on providing business management solutions to small and medium sized companies where she was responsible for leadership and development of an entire project delivery team with full P&L responsibility. She played a key role in guiding overall strategy of the company and at the same time provided leadership for operational improvements.



Dr. Bradley Patay

## **Dr. Bradley Patay, M.D., Chief Medical Officer**

Dr. Patay is dedicated to improving health by integrating genomic knowledge into medical care. He has authored numerous articles in this field, presented at multiple conferences and has been featured in Bloomberg Business Week. He has been head of the internal medicine section at Scripps Torrey Pines, worked as an Assistant Professor at STSI, and has been a founding member of the Board, and Vice President of the College of Genomic Medicine, which was established in 2010 to educate physicians and other health care professionals about genomic medicine.

His diverse clinical experience prior to joining Scripps Clinic in 2005 includes four years as an internist and pediatrician at Neighborhood Healthcare, a private, nonprofit community healthcare practice, and at Palomar Hospital. At these institutions, Brad cared for a wide range of patients, from neonates to the elderly, in both intensive care and the general wards. Through his service on several committees, he helped improve health care institutions' systems.



Paul McMullin

## **Paul McMullin, Head of Global Sales & Marketing**

Paul McMullin joined Invivoscribe in 2018 as the Head of Global Sales & Marketing. In this role, he leads Invivoscribe's worldwide Sales and Marketing efforts with focus on both Diagnostic and Companion Diagnostics (CDx) Products. These Products are sold in over 100 Countries via a Direct Sales Organization as well as Exclusive Distributors.

Mr. McMullin has over 35 years of experience working in the Medical Diagnostics Business. Most of that time has been in the molecular and biotechnology fields. His experience includes numerous positions in Sales and Marketing, establishing Direct Sales, Service and Support companies in Europe and Australia, and managing Distributor Sales in over 55 countries worldwide. He has directly managed employees in Japan, China and most major EU countries.

# 2019 PRESS HIGHLIGHTS



MAY 21, 2019

## **Invivoscribe Expanding Clinical Laboratory Network Space and Testing Capabilities in San Diego, Germany, Japan, and China. Offering Comprehensive Standardized Testing for All Hematologic Malignancies**

Invivoscribe, Inc., a vertically integrated global company focused on Improving Lives with Precision Diagnostics®, today announces expansion of space and testing capabilities in their international network of accredited LabPMM® clinical laboratories. Additions to the test menu will include morphology, IHC, flow cytometry, as well as the latest multiparameter flow- (MPF), and NGS-based minimal residual disease (MRD) testing of primary specimens. These new services will further support rapid patient diagnosis, study subject enrollment, and study subject stratifications. They will be available by end of this year in San Diego followed by the laboratories in Japan, Germany and China.

JUNE 19, 2019

## **Japan's MHLW Approves Invivoscribe's LeukoStrat CDx FLT3 Mutation Assay as the CDx for Daiichi Sankyo's Quizartinib for Treatment of Relapsed/Refractory FLT3-ITD AML. Expands Use to Include Specimens Collected in EDTA**

Invivoscribe is pleased to announce that on June 5th the Ministry of Health, Labor and Welfare (MHLW) approved our LeukoStrat® CDx FLT3 Mutation Assay as the companion diagnostic for Daiichi Sankyo's Quizartinib for the treatment of FLT3-ITD positive relapse/ refractory acute myeloid leukemia (AML) patients in Japan. At the same time the Japanese MHLW added approval in use of EDTA collection tubes to the existing approval of heparin collection tubes used with this assay.

DECEMBER 05, 2019

## **The European Commission Approves Astellas' XOSPATA® for Patients with Relapsed or Refractory Acute Myeloid Leukemia with a FLT3 Mutation Detected by Validated Tests, including the Invivoscribe LeukoStrat CDx FLT3 Mutation Assay**

For twenty-five years, Invivoscribe has improved the quality of healthcare worldwide by providing high quality, standardized reagents, tests, and bioinformatics tools to advance the field of precision medicine. The LeukoStrat® CDx FLT3 Mutation Assay may now be used as an aid in the assessment of AML patients for treatment with XOSPATA® (gilteritinib) in Europe. FLT3 mutation must be confirmed with a validated test, such as the LeukoStrat CDx FLT3 Mutation Assay, which served as the companion diagnostic in the Phase 3 ADMIRAL trial resulting in approval of XOSPATA®.

Companion diagnostics play a key role in the development and approval of targeted drug therapies. The ability to screen for biomarkers in a patient population creates patient subsets which further enables drug developers in the design of novel therapeutics and management of clinical trials. Accordingly, the successful approval of a targeted therapy is highly dependent on the performance of the companion diagnostic.

# 2019 PRODUCT HIGHLIGHTS

AUGUST 26, 2019

## **NOW AVAILABLE! MRD solutions for B- and T-cell clonality tracking**

Minimal Residual Disease (MRD) is the presence of low levels of malignant cells that remain in a subject during or after treatment or when the patient is in remission. Detectable levels of cancer cells following treatment may suggest a higher probability of relapse.



 LymphoTrack<sup>®</sup>  
Assays

 LymphoTrack<sup>®</sup> Dx  
Assays

 IdentiClone<sup>®</sup>

LeukoStrat<sup>®</sup>  
Assays

BEST-IN-CLASS  
ASSAYS & REAGENTS

Invivoscribe provides a full range of standardized CE-marked *in vitro* diagnostic cGMP products for hematology-oncology, as well as RUO assays, analyte specific reagents (ASRs), and DNA & RNA controls.

CELEBRATING  
25 YEARS

IMPROVING LIVES WITH  
PRECISION DIAGNOSTICS<sup>®</sup>



# BEST-IN-CLASS ASSAYS & REAGENTS

Invivoscribe provides a full range of standardized CE-marked *in vitro* diagnostic cGMP products for hematology-oncology, as well as RUO assays, analyte specific reagents (ASRs), and DNA & RNA controls.

## Next-Generation Sequencing

NGS is a powerful, high-throughput DNA sequencing technology that allows for massively parallel sequencing of millions of DNA fragments in a single sequencing run. NGS is revolutionizing modern science and healthcare.

## ABI Fluorescence Detection

We exclusively offer a comprehensive selection of PCR-based assays for ABI fluorescence detection, including targeted *FLT3* ITD and TKD mutation assays, B- and T-cell clonality assays (based on EuroClonality/BIOMED-2 Concerted Action BMH4-CT98-3936), and translocation assays.

## Gel Detection

We exclusively offer a comprehensive selection of PCR-based assays for gel detection, including targeted *FLT3* ITD and TKD mutation assays, B- and T-cell clonality assays (based on EuroClonality/BIOMED-2 Concerted Action BMH4-CT98-3936), and translocation assays.

## Controls & Reagents

Invivoscribe offers an extensive range of General Purpose Reagents (GPRs) and Research Use Only (RUO) nucleic acid controls.

## Companion Diagnostics (CDx)

Invivoscribe is a Comprehensive Partner for Companion Diagnostic Development.



LABPMM®

## CLINICAL LAB SERVICES

The Laboratory for Personalized Molecular Medicine® (LabPMM®) at Invivoscribe offer internationally standardized testing of novel and proprietary biomarkers that are critically important for patient care.

CELEBRATING  
25 YEARS

IMPROVING LIVES WITH  
PRECISION DIAGNOSTICS®

L A B P M M <sup>®</sup>

# CLINICAL LAB SERVICES

The Laboratory for Personalized Molecular Medicine<sup>®</sup> (LabPMM<sup>®</sup>) at Invivoscribe offer internationally standardized testing of novel and proprietary biomarkers that are critically important for patient care.

## NGS Cancer Panels

Cytogenetic identification of chromosome abnormalities has become essential for the clinical management of patients with leukemia and is currently used to help categorize patients into risk groups.

## MRD NGS Tests

LabPMM's MRD tests are NGS-based assays that can be used to detect clonal gene rearrangements identified at diagnosis within virtually all of the antigen receptor loci for both B- and T-cells.

## Targeted Genes

*FLT3* and *NPM1* assays are offered to detect targeted mutations.

## Clonality NGS Tests

The unique process of genetic rearrangements in the immunoglobulin (Ig) and T-cell receptor (TCR) gene loci during immune cell development and maturation generates a vast pool of genetically distinct cells.

## Companion Diagnostics (CDx) Tests

The fms related tyrosine kinase 3 (*FLT3*) is one of the most commonly mutated genes in acute myeloid leukemia (AML), occurring in approximately 30% of patients at the time of diagnosis.<sup>1</sup> Although generally associated with normal cytogenetics where patients have standard risk of relapse, *FLT3* mutations have also been identified in sub-groups of patients with chromosomal abnormalities that are associated with high risk of disease relapse.<sup>2-3</sup>

## Custom Assays

In response to the FDA announcing its intention to dramatically expand its regulatory oversight of laboratory developed tests (LDTs), Invivoscribe is partnering with laboratories worldwide to help facilitate the conversion of LDTs into FDA-cleared assays, as we know the barriers to bringing new assays online are often the availability of resources and the cost of validation.

1. Acute Myeloid Leukemia, Clinical Practice Guidelines in Oncology, (v.2.2014) National Comprehensive Cancer Network.  
2. Lowenberg, B. et al. (1999) "Acute myeloid leukemia." *N Engl J Med* 341(14):1051-62.  
3. Thiede, C. et al. (2002) "Analysis of FLT3-activating mutations in 979 patients with acute myelogenous leukemia: association with FAB and identification of subgroups with poor prognosis." *Blood* 99(12): 4326-35.



STREAMLINED  
CDX PARTNERSHIPS

Companion Diagnostics represents a critical milestone in precision medicine and plays a pivotal role in the validation of targeted therapies. Traditional CDx development models involve multiple partners adding complexity and increasing risk which could affect drug approvals.

CELEBRATING  
25 YEARS

IMPROVING LIVES WITH  
PRECISION DIAGNOSTICS\*

# STREAMLINED CDX PARTNERSHIPS

Our Streamlined CDx™ program has demonstrated value, accelerating the international approvals of multiple new targeted therapies for multiple pharmaceutical companies.

## Product Development

<b>Design Controls</b>	<b>Bioinformatics Software</b>	<b>Identify &amp; Track</b>	<b>Custom Development</b>	<b>Complementary MRD Assays</b>
All biomarker assays & software developed under design controls.	Comprehensive LymphoTrack® Dx clonality with bioinformatics software.	Multiple NGS gene panels that identify and track clinically-actionable biomarkers.	Custom biomarker assay development.	Complementary MRD assays for all biomarkers – potential for surrogate endpoints per agency inputs.

## Manufacturing

<b>cGMP Compliant</b>	<b>CE-marked IVDs &amp; CDx Manufacturing</b>	<b>Assay Development</b>	<b>Controls &amp; Reagents</b>
US FDA/CDRH registered, EN ISO 13485:2016 certified manufacturing facility based in San Diego	PMA companion diagnostics (CDx) for US and Japan, inclusion of CDx in ARTG Australia and >50 CE-IVDs (NGS assays include bioinformatics software).	IUO & RUO assays, CE-marked IVDs, & CDx.	DNA / RNA controls, ASRs, GPRs, MRD controls & proficiency panels.

## LabPMM®

<b>Clinical Lab Experience</b>	<b>Internationally Standardized</b>	<b>Comprehensive Panels</b>	<b>Complementary MRD Assays</b>	<b>Worldwide Enrollment</b>
A dozen years of clinical reference lab experience.	Internationally standardized CDx and biomarker testing with internationally accredited labs serving the US, Europe, and Asia.	Comprehensive LymphoTrack® clonality/MRD assays and NGS MyGene™ panels identify clinically-actionable biomarkers.	Complementary MRD assays for all biomarkers – potential for surrogate future endpoints per agency inputs.	Testing services have supported hundreds of enrollment sites worldwide.

## Global Regulatory Expertise

<b>Accredited &amp; Proven</b>	<b>Registered Medical Device Establishment</b>	<b>Multiple CDx Approvals</b>	<b>CE-marked IVDs</b>	<b>Marketing Authorization Holder (MAH)</b>
EN ISO 13485:2016 accredited. Experienced staff & proven Quality Management System.	Registered Medical Device Establishment with the US FDA, KFDA, Saudi Arabia, and the MHLW/PMDA.	Multiple CDx approvals supporting various drugs: by the FDA (US), PMDA/MHLW (Japan), and TGA (Australia). CDx CE-marked IVD in the EU.	>50 CE-marked IVDs available in the EU and select ROW markets; >60 tests included in the ARTG in Australia.	Marketing Authorization Holder (MAH) and national reimbursement for CDx in Japan.



CONTACT

Complete directory  
online at [invivoscribe.com](http://invivoscribe.com)

# GLOBAL DISTRIBUTOR NETWORK

A long and proud history of working with scientists, laboratorians and clinicians from around the world. We offer product support in over 160 countries. Our distributor partners are in locations around the globe.

## AFRICA

ALGERIA  
ANGOLA  
BURKINA FASO  
BURUNDI  
CAMEROON  
CHAD  
CÔTE D'IVOIRE  
EGYPT  
EQUATORIAL GUINEA  
ESWATINI  
ETHIOPIA  
GABON  
GHANA  
KENYA  
MADAGASCAR  
MALI  
MOROCCO  
MOZAMBIQUE  
NAMIBIA  
NIGERIA  
REPUBLIC OF THE CONGO  
SENEGAL  
SIERRA LEONE  
SOUTH AFRICA  
TANZANIA  
TUNISIA  
UGANDA  
ZAMBIA  
ZIMBABWE

## ASIA

AFGHANISTAN  
ARMENIA  
AZERBAIJAN  
BANGLADESH  
CHINA  
HONG KONG  
INDIA  
INDONESIA  
JAPAN  
KYRGYZSTAN  
MALAYSIA  
NEPAL  
PHILIPPINES  
SINGAPORE  
SOUTH KOREA  
SRI LANKA  
TAIWAN  
TAJKISTAN  
THAILAND  
TURKMENISTAN  
UZBEKISTAN  
VIETNAM

## AUSTRALIA / NEW ZEALAND

AUSTRALIA  
NEW ZEALAND

## EUROPE

AUSTRIA  
BELARUS  
BELGIUM  
BULGARIA  
CROATIA  
CZECH REPUBLIC  
DENMARK  
ESTONIA  
FINLAND  
FRANCE  
GERMANY  
GREECE  
ICELAND  
IRELAND  
ITALY  
KAZAKHSTAN  
LATVIA  
LITHUANIA  
LUXEMBOURG  
MONACO  
NETHERLANDS  
NORWAY  
POLAND  
PORTUGAL  
ROMANIA  
RUSSIA  
SERBIA  
SLOVAKIA  
SLOVENIA  
SPAIN  
SWEDEN  
SWITZERLAND  
UNITED KINGDOM

## MIDDLE EAST

BAHRAIN  
IRAN  
IRAQ  
ISRAEL  
JORDAN  
KUWAIT  
LEBANON  
OMAN  
PAKISTAN  
PALESTINE  
QATAR  
SAUDI ARABIA  
TURKEY  
UNITED ARAB EMIRATES  
YEMEN

## CENTRAL AMERICA

CARIBBEAN  
COSTA RICA  
EL SALVADOR  
GUATEMALA  
HONDURAS  
NICARAGUA  
PANAMA

## NORTH AMERICA

CANADA  
MEXICO  
UNITED STATES

## SOUTH AMERICA

ARGENTINA  
BRAZIL  
CHILE  
COLOMBIA  
PERU  
URUGUAY

# Table of Contents

## Introduction

Letter to Our Colleagues	2
Board of Directors	4
Executive Leadership Team	6
Best-in-Class Assays & Reagents	8
LabPMM Clinical Lab Services	10
Streamlined CDx Partnerships	12
Global Distributor Network	14

## Background

Introduction	16
Test Algorithm for Suspect Lymphoproliferations	17

## Next-Generation Sequencing (NGS)

LymphoTrack® Dx Assays	18
LymphoTrack Dx <i>IGHV</i> Leader Somatic Hypermutation Assay	20
LymphoTrack Dx <i>IGH</i> FR1/2/3 Assays	22
LymphoTrack Dx <i>IGK</i> Assays	26
LymphoTrack Dx <i>TRG</i> Assays	28
LymphoTrack Dx <i>TRB</i> Assays	30
LymphoTrack Dx Bioinformatics Software	32

LymphoTrack® - Research Use Only (RUO) Assays	34
LymphoTrack <i>IGHV</i> Leader Somatic Hypermutation Assay	36
LymphoTrack <i>IGH</i> FR1/FR2/FR3 Assays	38
LymphoTrack <i>IGK</i> Assays	42
LymphoTrack <i>TRG</i> Assays	44
LymphoTrack <i>TRB</i> Assays	46
LymphoTrack Bioinformatics Software	48

LymphoTrack® MRD Solution - Research Use Only (RUO)	50
LymphoTrack Minimal Residual Disease (MRD) Software	52
LymphoTrack B-cell & T-cell Low Positive Controls	54
LymphoQuant B-cell & T-cell Internal Control	55

## Gel and Capillary

IdentiClone® Assays	56
<i>IGH + IGK</i> B-Cell Clonality Assays	58
<i>IGH</i> Gene Clonality Assays	60
<i>IGK</i> Gene Clonality Assays	62
<i>IGL</i> Gene Clonality Assays	64
<i>TCRB + TCRG</i> T-Cell Clonality Assays	66
<i>TCRB</i> Gene Clonality Assays	68
T-Cell Receptor Gamma Gene Rearrangement Assay 2.0	70
<i>TCRG</i> Gene Clonality Assays	72
<i>TCRD</i> Gene Clonality Assays	74
<i>BCL1/JH</i> Translocation Assay	76
<i>BCL2/JH</i> Translocation Assay	78

LeukoStrat® Assays	80
<i>FLT3</i> Mutation Assay - Gel Detection	82
<i>FLT3</i> Mutation Assay 2.0 - ABI Fluorescence Detection	84
CDx <i>FLT3</i> Mutation Assay (CE-marked)	86
CDx <i>FLT3</i> Mutation Assay - AUS	88
CDx <i>FLT3</i> Mutation Assay - Japan	90

Gel and Capillary - Research Use Only (RUO) Assays	92
<i>IGH + IGK</i> B-Cell Clonality Assays	94
<i>IGH</i> Gene Rearrangement Assays	96
<i>IGH</i> Gene Clonality Assays	98
<i>IGK</i> Gene Clonality Assays	100
<i>IGL</i> Gene Clonality Assays	102
<i>TCRB + TCRG</i> T-Cell Clonality Assays	104
<i>TCRB</i> Gene Clonality Assays	106
T-Cell Receptor Gamma Gene Rearrangement Assay 2.0	108
T-Cell Receptor Gamma Gene Rearrangement Assays	110
<i>TCRG</i> Gene Clonality Assays	112
<i>TCRD</i> Gene Clonality Assays	114
<i>BCL1/JH</i> Translocation Assay	116
<i>BCL2/JH</i> t(14;18) Translocation Assay	118
<i>BCL2/JH</i> Translocation Assay	120
<i>BCR/ABL</i> t(9;22) Translocation Assays	122
<i>PML/RAR<math>\alpha</math></i> t(15;17) Translocation Assays	124
<i>IGH</i> Somatic Hypermutation Assays v2.0	126
<i>FLT3</i> Mutation Assays	128

## Analyte Specific Reagents

Analyte Specific Reagents	130
---------------------------	-----

## Controls, Reagents, and Enzymes

Overview	132
DNA Controls	134
Low Positive Controls	138
Internal Controls	139
RNA Controls	140
Control Panels	144
Master Mix Controls	146

## Custom Products

Custom Products	148
-----------------	-----

## Reference

Clonality Testing Workflow Methods	151
Illumina® MiSeq® Workflow Summary	152
Thermo Fisher Scientific® Ion S5™ PGM™ Workflow Summary	153
Next-Generation Sequencing Menu	154
Gel and Capillary Electrophoresis Menu	155
Common Technical Support Questions	156
Recent Poster Abstracts	160

## Product List

Product List by Catalog Number	162
--------------------------------	-----

## Index

Alphabetical Index	165
--------------------	-----

# Background

## PCR & NGS-Based Assessment of Clonality in Hematologic Malignancies

---

Over its 25 year history, Invivoscribe has developed, manufactured, and commercialized the gold-standard molecular hematopathology assays and reagents for gel and capillary electrophoresis detection, and most recently, next-generation sequencing instruments. These standardized, cGMP manufactured assays and reagents were developed and validated using standardized workflow and optimized primer sets, reagents and controls.

A number of our products were developed in collaboration with studies conducted by the EuroClonality BIOMED-2 concerted action group; these capillary based products have provided reliable methods for clonality detection that have withstood the test of time.

We have never accepted the status quo, so our comprehensive menu of clonality assays continues to evolve. All of our NGS-based clonality assays were developed in-house together with accompanying bioinformatics software by our Invivoscribe R&D team. Developed under full ISO 13485 design control, these assays and bioinformatics software were designed to run on several next-generation sequencing platforms. These NGS-based assays are several generations ahead of capillary-based products.

Our comprehensive bioinformatics software not only provides critical information on the presence of clonality, but also identifies the sequence information required to track clones in subsequent samples.

The unique process of gene rearrangement that occurs within the immunoglobulin (*Ig*) and T-cell receptor (*TCR*) gene loci during immune cell development and maturation generates a vast pool of genetically distinct cells. The resulting diverse population of lymphocytes displays an astonishing number of diverse antigen receptors, each coded in the DNA by a unique sequence, and each displayed on the cell surface, or as antibodies in the blood unique to a given cell.<sup>1,2</sup> This diversity allows the adaptive immune system to carry out its role in protecting the human body by recognizing the infinite number of pathogens it might encounter during a lifetime.

In sum, lymphoid malignancies are characterized by size- and sequence-specific rearrangements within these loci, which result from the transformation and subsequent proliferation from a single cell. The associated cellular population typically shares one or more cell-specific or "clonal" antigen-receptor gene rearrangements. The detection of these clonal cells forms the basis for clonality assessment in leukemia, lymphoma, and hematologic disease. These methods can also be used to assess somatic hypermutation (SHM) and to study minimal residual disease (MRD).

Malignant cells that remain in the bone marrow following treatment are a major cause of disease relapse. MRD testing by NGS offers enhanced sensitivity and specificity (compared to MRD testing by flow cytometry), and allows residual cells to be identified at very low levels and monitored throughout the different stages of disease.

Invivoscribe can provide you with the necessary tools to accommodate your needs. From gel detection to NGS, we can help you accurately identify and track hematologic biomarkers.

For additional information on the detection methods available and the biomarkers offered, please refer to the respective product sections of this catalog.

## Immunoglobulin and T-Cell Receptor Gene Rearrangements and the Principle and Method of Clonality Testing

---

The adaptive vertebrate immune system produces a repertoire of immunoglobulin and T-cell receptor molecules using a relatively limited number of heritable germline gene segments. Somatic gene rearrangement is the fundamental mechanism used to generate different immunoglobulin and T-cell receptor molecules, each with unique binding specificity. Lymphocytes undergo gene rearrangements to assemble CDR3 coding regions that are unique in both size and DNA sequence. Since leukemias and lymphomas arise from the malignant transformation of a single cell, they share clonal rearrangement(s) of the antigen receptor genes. This is the basis for clonality testing.<sup>3</sup>

### References:

1. Tonegawa, S. Somatic Generation of Antibody Diversity. *Nature* 302:575-581 (1983)
2. Expression of T-cell receptor genes during early T-cell development. *Immunol Cell Biol.* 2008 Feb;86(2):166-74. Epub 2007 Oct 23.
3. Miller, J. E. (2013). Principle of Immunoglobulin and T cell Receptor Gene Rearrangement. In Cheng, L., Zhang, D., Eble, J. N. (Eds), *Molecular Genetic Pathology* (2nd Ed., Sections 30.2.7.13 and 30.2.7.18). pp825 – 856. New York, USA: Springer Science & Business Media.



# Test Algorithm for Suspect Lymphoproliferations

Developed in concert with the EuroClonality/BIOMED-2 group for PCR-based clonality assessment of suspected B- and T-cell lymphoproliferative disorders.

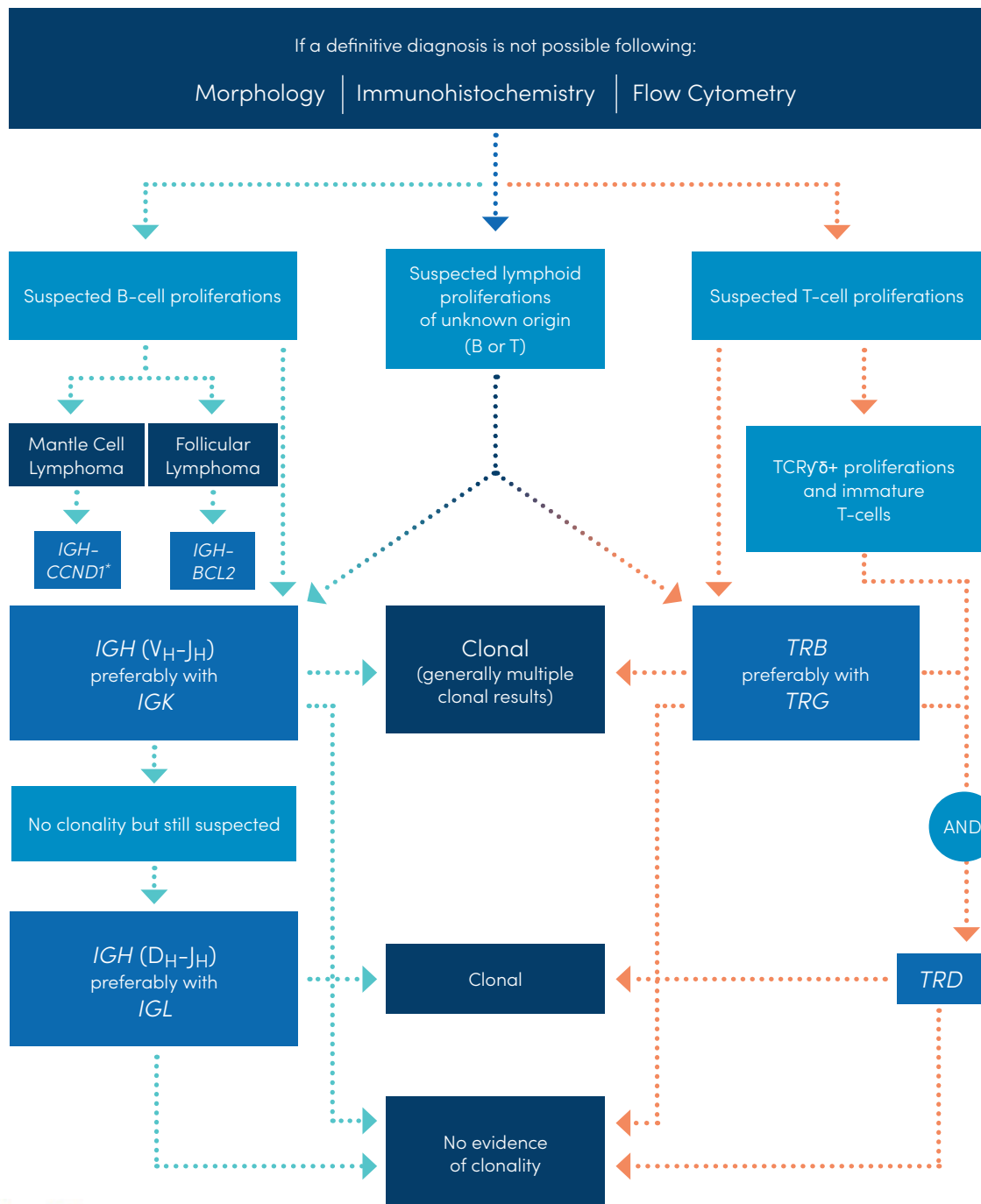

\*Previously known as *BCL1/JH*  
Results should be considered in the context of all available clinical, histological and immunophenotypic data.

# LymphoTrack<sup>®</sup> Dx Assays

## Next-Generation Sequencing (NGS) Assays

### Key Benefits

- » One-step PCR for amplicon and library generation
- » Identify, track, and assess mutation status of B- and T-cell gene rearrangements
- » Sequence amplicons from any LymphoTrack Dx kit together
- » Included bioinformatics software for easy analysis and interpretation

20 / LymphoTrack<sup>®</sup> Dx *IGHV* Leader Somatic  
Hypermutation Assay

28 / LymphoTrack<sup>®</sup> Dx  
*TRG* Assays

22 / LymphoTrack<sup>®</sup> Dx  
*IGH* FR1/2/3 Assays

30 / LymphoTrack<sup>®</sup> Dx  
*TRB* Assays

26 / LymphoTrack<sup>®</sup> Dx  
*IGK* Assays

32 / LymphoTrack<sup>®</sup> Dx  
Bioinformatics Software

### Warranty and Liability

Invivoscribe, Inc. (Invivoscribe<sup>®</sup>) is committed to providing the highest quality products. Invivoscribe<sup>®</sup> warrants that the products meet or exceed the performance standards described in the Instructions For Use, as to products with such an insert. If a product is covered by product specifications and does not perform as specified, our policy is to replace the product or credit the full purchase price. No other warranties of any kind, expressed or implied, are provided by Invivoscribe. Invivoscribe liability shall not exceed the purchase price of the product. Invivoscribe shall have no liability for direct, indirect, consequential, or incidental damages arising from the use, results of use, or inability to use its products; product efficacy under purchaser controlled conditions in purchaser's laboratory must be established and continually monitored through purchaser defined and controlled processes including but not limited to testing of positive, negative, and blank controls every time a sample is tested. Ordering, acceptance, and use of product constitutes purchaser acceptance of sole responsibility for assuring product efficacy and purchaser agreement to the limitation of liability set forth in this paragraph.

NOTICE: These are *in vitro* diagnostic products and are not available for sale or use within North America. Many of the products listed in the section that follows are covered by one or more of the following patents and patent applications owned by or exclusively licensed to Invivoscribe, Inc.: United States Patent Number 7,785,783, United States Patent Number 8,859,748, United States Patent 10,280,462, European Patent Number EP 1549764B1 (validated in 16 countries, and augmented by related European Patents Numbered EP2418287A3 and EP 2460889A3), Japanese Patent Number JP04708029B2, Japanese Patent Application Number 2006-529437, Brazil Patent Application Number PI0410283.5, Canadian Patent Number CA2525122, Indian Patent Number IN243620, Mexican Patent Number MX286493, Chinese Patent Number CN1806051, and Korean Patent Number 101215194.

These products use nucleic acid amplification methods such as Polymerase Chain Reaction (PCR). Any necessary license to practice amplification methods or to use reagents, amplification enzymes or equipment covered by third party patents is the responsibility of the user and no such license is granted by Invivoscribe, Inc., expressly or by implication.

# LymphoTrack<sup>®</sup> Dx

Assays

LymphoTrack Dx Assay kits are designed for the identification of gene rearrangements in hematologic samples utilizing next-generation sequencing (NGS) technologies.

These assays take advantage of the wealth and depth of data generated by the Illumina<sup>®</sup> MiSeq<sup>®</sup>, Thermo Fisher Scientific<sup>®</sup> Ion PGM<sup>™</sup> and Ion S5<sup>™</sup> platforms.

The Invivoscribe NGS assays offer significant improvements over conventional fragment analysis of B- and T-cell gene rearrangements by providing detailed information regarding the DNA sequences, sequence frequency, and mutational status (*IGHV* Leader and *IGH* FR1 only) of each clonotype.

LymphoTrack Dx Assay kits are a complete solution. Kits contain ready-to-use indexed amplification master mixes, necessary controls, and complimentary bioinformatics software. As primers are designed with barcoded indices and adapters, sequencing libraries can be generated with a single PCR, streamlining the overall workflow, eliminating the need for a post-PCR ligation step, and reducing the potential for sample cross contamination.

The per sample testing costs can be reduced by pooling samples from different LymphoTrack Dx Assays into a single sequencing run. The included bioinformatics software will sort the complex NGS data for easy analysis and visualization of individual samples.

Detailed instructions for use are provided with all kits and the Invivoscribe technical support team is always available to answer your questions.

For more information, please visit [www.invivoscribe.com](http://www.invivoscribe.com)

**NOTICE:**

The LymphoTrack Dx Assays are *in vitro* diagnostic products and are not available for sale or use within North America. For more information regarding the research use only reagents, please see the Next-Generation Sequencing - LymphoTrack section.

## LymphoTrack Dx IGHV Leader Somatic Hypermutation Assay

### Assay Description

The LymphoTrack Dx IGHV Leader Somatic Hypermutation Assay for the Illumina<sup>®</sup> MiSeq<sup>®</sup> is an *in vitro* diagnostic product intended for next-generation sequencing (NGS) based determination of the frequency distribution of IGH gene rearrangements, as well as the degree of somatic hypermutation (SHM) of rearranged genes in patients suspected of having lymphoproliferative disease. This assay aids in the identification of lymphoproliferative disorders as well as providing an aid in determining disease prognosis. If you would like to test for IGHV somatic hypermutation using the Thermo Fisher<sup>®</sup> Ion PGM<sup>™</sup> or Ion S5<sup>™</sup> platform, please refer to the LymphoTrack Dx IGH FR1 Assay (9-121-0007).

### Summary and Explanation of the Test

The NGS LymphoTrack Dx IGHV Leader Somatic Hypermutation Assay for the Illumina<sup>®</sup> MiSeq<sup>®</sup> represents a significant improvement over clonality assays using fragment analysis as it efficiently detects the majority of IGH gene rearrangements using a single multiplex master mix, identifies the DNA sequence specific for each clonal gene rearrangement, and assesses the somatic hypermutation rate of clonal samples in the same workflow.

The single multiplex master mixes target the Leader (VHL) and the joining (JH) gene regions of the IGH locus and are designed with Illumina<sup>®</sup> adapters and indices (8 included in Kit A and 24 included in the Panel). This allows for a one-step PCR reaction and pooling of amplicons from several different samples and targets into a single Illumina<sup>®</sup> MiSeq<sup>®</sup> run. No post-PCR ligation step is required.

The included LymphoTrack Dx Bioinformatics Software enables simplified analysis and visualization of individual sample data.

Positive (clonal positive, SHM negative), negative (polyclonal) and SHM (clonal positive, SHM positive) DNA controls are included in the kits.

### Background

The human immunoglobulin heavy chain (IGH) gene locus on chromosome 14 (14q32.3) includes 46–52 functional and 30 nonfunctional variable (VH) gene segments, 27 functional diversity (DH) gene segments, and 6 functional joining (JH) gene segments spread over 1,250 kilobases.

During B-cell development, genes encoding the IGH protein are assembled from multiple polymorphic gene segments that undergo rearrangements and selection, generating cell specific VH-DH-JH rearrangements that are unique in both length and sequence.

Since leukemias and lymphomas originate from the malignant transformation of individual lymphoid cells, all leukemias and lymphomas generally share one or more cell-specific or "clonal" antigen receptor gene rearrangements. Therefore, tests that detect IGH clonal rearrangements can be useful in the study of B- cell malignancies. An additional level of diversity is further generated in the antigen receptors by introducing point mutations in the variable regions, also named SHM. In instances where there is a high degree of SHM, there is the risk that primers located within the variable region will not be able to bind and clonal products will not amplify. In these cases, the leader primers located upstream of the variable region can be beneficial for the detection of clonal products, due to the conserved nature of the VHL region. In addition, the SHM rate of the entire variable gene can be determined using the VHL primers.

Determining the immunoglobulin variable heavy chain gene (IGHV) hypermutation rate is considered a gold standard for determining the prognosis of patients with chronic lymphocytic leukemia (CLL) and small lymphocytic lymphoma (SLL). In addition, NGS methods can improve disease stratification.

### Specimen Requirement

50 ng of high-quality genomic DNA.

### References

1. B Stamatopoulos et al., *Leukemia* 4:837-845 (2017).
2. F Davi et al., *Leukemia* 22: 212-214 (2008).
3. JE Miller et al., *Molecular Genetic Pathology* (2nd ed.). Springer Science & Business Media. 2013: 302.2.7.13 and 30.2.7.18.
4. P Ghia et al., *Leukemia* 21: 2-3 (2007).
5. P Ghia et al., *Blood* 105: 1678-1685 (2005).
6. S Tonegawa. *Nature* 302: 575-581 (1983).



Simplified representation of the immunoglobulin heavy chain (IGH) gene locus on chromosome 14. Depicted are the variable (VH) and downstream consensus joining (JH) region genes involved in rearrangements. Upstream of the variable gene segments, the leader sequence (VHL) is also depicted. Diversity region genes are not depicted.

## Reagents - MiSeq<sup>®</sup> Detection

Kit A Components		Panel Components (includes all master mixes from Kit A plus the items below)			
Master Mix Name	Index #	Master Mix Name	Index #	Master Mix Name	Index #
IGH Leader MiSeq 01	A001	IGH Leader MiSeq 09	A009	IGH Leader MiSeq 18	A018
IGH Leader MiSeq 02	A002	IGH Leader MiSeq 10	A010	IGH Leader MiSeq 19	A019
IGH Leader MiSeq 03	A003	IGH Leader MiSeq 11	A011	IGH Leader MiSeq 20	A020
IGH Leader MiSeq 04	A004	IGH Leader MiSeq 12	A012	IGH Leader MiSeq 21	A021
IGH Leader MiSeq 05	A005	IGH Leader MiSeq 13	A013	IGH Leader MiSeq 22	A022
IGH Leader MiSeq 06	A006	IGH Leader MiSeq 14	A014	IGH Leader MiSeq 23	A023
IGH Leader MiSeq 07	A007	IGH Leader MiSeq 15	A015	IGH Leader MiSeq 25	A025
IGH Leader MiSeq 08	A008	IGH Leader MiSeq 16	A016	IGH Leader MiSeq 27	A027
Controls		Controls			
IGH SHM POS (+) Qty. 1		IGH SHM POS (+) Qty. 3			
IGH POS (+) Qty. 1		IGH POS (+) Qty. 3			
NGS NEG (-) Qty. 1		NGS NEG (-) Qty. 3			

Rank	Sequence	Length	Merge count	V-gene	J-gene	% Total reads	Cumulative %	Mutation rate partial V-gene (%)	In-frame (Y/N)	No stop codon (Y/N)	V-coverage
1	TTCTCGTGGTG	455	29603	IGHV4-59_08	IGHJ4_02	9.93	9.93	11.26	Y	Y	98.63
2	CTCGCCCTCCT	463	205	IGHV5-51_01	IGHJ4_02	0.07	9.99	0.00	Y	Y	99.66
3	GGTTTTCCCTTG	484	201	IGHV3-7_01	IGHJ4_02	0.07	10.06	7.77	Y	Y	100.00
4	CTCGCCCTCCT	463	185	IGHV5-51_01	IGHJ5_02	0.06	10.12	6.08	Y	Y	99.32
5	CTCGCCCTCCT	469	170	IGHV5-51_01	IGHJ4_02	0.06	10.18	0.00	Y	Y	99.32
6	CTCGCCCTCCT	466	160	IGHV5-51_01	IGHJ4_02	0.05	10.23	0.00	Y	Y	99.66
7	CTGCTGCTGAC	460	159	IGHV2-5_10	IGHJ5_02	0.05	10.29	8.08	Y	Y	97.64
8	GGTTTTCCCTTG	493	156	IGHV3-48_02	IGHJ6_02	0.05	10.34	3.72	Y	Y	98.99
9	CTCGCCCTCCT	334	153	IGHV5-51_02	IGHJ2_01	0.05	10.39	3.72	Y	N	27.70
10	CTCGCCCTCCT	334	152	IGHV5-51_02	IGHJ2_01	0.05	10.44	3.38	Y	N	26.01

**Example Data.** The top 10 sequences from a read summary generated by the LymphoTrack Dx Software - MiSeq<sup>®</sup> with the SHM mutation rate and predictions pertaining to whether a sequence is in-frame or contains a premature stop codon are depicted. To learn more about the LymphoTrack Dx software, please refer to the LymphoTrack Dx Bioinformatics Software section.

## Ordering Information

Catalog #	Products	Quantity Components
9-121-0059	LymphoTrack <sup>®</sup> Dx IGHV Leader Somatic Hypermutation Assay Kit A - MiSeq <sup>®</sup>	8 indices - 5 sequencing reactions each
9-121-0069	LymphoTrack <sup>®</sup> Dx IGHV Leader Somatic Hypermutation Assay Panel - MiSeq <sup>®</sup>	24 indices - 5 sequencing reactions each
9-500-0009	LymphoTrack <sup>®</sup> Dx Software - MiSeq <sup>®</sup>	1 CD complimentary with purchase

CE  These products are CE-IVD assays for *in vitro* diagnostic use.

# LymphoTrack Dx IGH FR1/2/3 Assays

## Assay Description

### LymphoTrack Dx IGH FR1 Assays

The LymphoTrack Dx IGH FR1 Assay for the Illumina MiSeq<sup>®</sup> or Thermo Fisher Scientific<sup>®</sup> Ion S5<sup>™</sup> and Ion PGM<sup>™</sup> is an *in vitro* diagnostic product intended for next-generation sequencing (NGS) based determination of the frequency distribution of IGH gene rearrangements as well as the degree of somatic hypermutation of rearranged genes in patients suspected with having lymphoproliferative disease. This assay aids in the identification of lymphoproliferative disorders as well as providing an aid in determining disease prognosis.

### LymphoTrack Dx IGH FR1/2/3 Assays

The LymphoTrack Dx IGH FR1 Assay for the Illumina MiSeq<sup>®</sup> or Thermo Fisher Scientific<sup>®</sup> Ion S5<sup>™</sup> and Ion PGM<sup>™</sup> is an *in vitro* diagnostic product intended for next-generation sequencing (NGS) based determination of the frequency distribution of IGH gene rearrangements as well as the degree of somatic hypermutation of rearranged genes in patients suspected with having lymphoproliferative disease. This assay aids in the identification of lymphoproliferative disorders as well as providing an aid in determining disease prognosis.

This LymphoTrack Dx IGH FR2 Assay is an *in vitro* diagnostic product intended for next-generation sequencing (NGS) for the Illumina MiSeq<sup>®</sup> or Thermo Fisher Scientific<sup>®</sup> Ion S5<sup>™</sup> and Ion PGM<sup>™</sup> instruments. The assay will determine the frequency distribution of IGH V<sub>H</sub>-J<sub>H</sub> gene rearrangements in patients suspected with having lymphoproliferative disease. This assay aids in the identification of lymphoproliferative disorders.

The LymphoTrack Dx IGH FR3 Assay is an *in vitro* diagnostic product intended for next-generation sequencing (NGS) for the Illumina MiSeq<sup>®</sup> or Thermo Fisher Scientific<sup>®</sup> Ion S5<sup>™</sup> and Ion PGM<sup>™</sup> instruments. The assay will determine the frequency distribution of IGH V<sub>H</sub>-J<sub>H</sub> gene rearrangements in patients suspected with having lymphoproliferative disease. This assay aids in the identification of lymphoproliferative disorders.

## Summary and Explanation of the Test

The LymphoTrack Dx IGH Assays represent a significant improvement over conventional clonality assessment methods utilizing fragment analysis by providing four important and complementary uses in a single workflow:

1. Detection of clonal populations.
2. Identification of sequence information required to track clonal rearrangements in subsequent samples.
3. The LymphoTrack Dx IGH framework 1 FR1 master mixes provide the degree of SHM in the immunoglobulin variable heavy chain (IGHV) gene locus.
4. The ability to track sequences in subsequent samples with the Invivoscribe LymphoTrack MRD<sup>\*</sup> Software. For more information, please refer to page 52 and 53.

These assays utilize a single multiplex master mix to target each conserved IGH Framework Region (FR1, FR2, and FR3) within the V<sub>H</sub> and the J<sub>H</sub> regions described in lymphoid malignancies. The included primers are designed with Illumina<sup>®</sup> or Thermo Fisher Scientific adapters and indices (8-24 and 12, respectively).

This allows up to 24 samples on MiSeq<sup>®</sup> and 12 samples on Ion PGM<sup>™</sup> and Ion S5<sup>™</sup> to be sequenced at the same time with any of the individual FRs.

In addition, amplicons generated with different FR master mixes or Invivoscribe LymphoTrack Dx kits (such as IGH or TRG) can be pooled together in the same sequencing library to reduce testing costs. The associated LymphoTrack Dx Software provides interpretation of the data via a simple and streamlined method of analysis and visualization. By following the guidelines provided in the instructions for use, samples can be interpreted for evidence of clonality and SHM rates.

Positive clonal (SHM negative) and negative polyclonal DNA controls are included in kits. A clonal SHM positive control can be purchased separately (cat#: 4-088-0008).

## Background

The human immunoglobulin heavy chain (IGH) gene locus on chromosome 14 (14q32.3) includes 46-52 functional and 30 non-functional variable (V<sub>H</sub>), 27 functional diversity (D<sub>H</sub>), and 6 functional joining (J<sub>H</sub>) gene segments. The V<sub>H</sub> gene segments can be further broken down into three conserved frameworks (FR) and three variable complementarity-determining regions (CDRs).

During development of lymphoid cells, antigen receptor genes undergo somatic gene rearrangements. Specifically during B-cell development, IGH molecules are assembled from multiple polymorphic gene segments that undergo rearrangements generating V<sub>H</sub>-D<sub>H</sub>-J<sub>H</sub> combinations unique in both length and sequence. Since leukemias and lymphomas originate from the malignant transformation of individual lymphoid cells, all leukemias and lymphomas generally share one or more cell-specific or "clonal" antigen receptor gene rearrangements.

In addition, the IGHV hypermutation status obtained with the LymphoTrack Dx IGH FR1 master mixes, provides important prognostic information for patients with chronic lymphocytic leukemia (CLL) and small lymphocytic lymphoma (SLL). The SHM rate has been shown to have clinical relevance for CLL, as there is a clear distinction in the median survival of patients with and without SHM.<sup>1</sup>

## Specimen Requirement

50 ng of high-quality genomic DNA.

## References

1. P. Ghia et al., Blood 105: 1678-1685 (2005).

## Simplified Representation of the IGH Gene

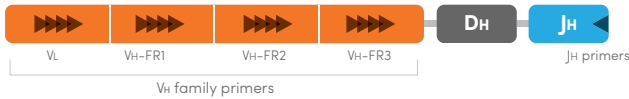

Simplified depiction of variable (VH) and downstream consensus joining (JH) region genes involved in gene rearrangements.

## Reagents - MiSeq<sup>®</sup> Detection

The LymphoTrack Dx IGH FR1/2/3 Assays contain components from respective individual FR kit A's or panels.

LymphoTrack Dx IGH FR1 Components		LymphoTrack Dx IGH FR2 Components		LymphoTrack Dx IGH FR3 Components	
Master Mix Name	Index #	Master Mix Name	Index #	Master Mix Name	Index #
IGH FR1 MiSeq 01	A001	IGH FR2 MiSeq 01	A001	IGH FR3 MiSeq 01	A001
IGH FR1 MiSeq 02	A002	IGH FR2 MiSeq 02	A002	IGH FR3 MiSeq 02	A002
IGH FR1 MiSeq 03	A003	IGH FR2 MiSeq 03	A003	IGH FR3 MiSeq 03	A003
IGH FR1 MiSeq 04	A004	IGH FR2 MiSeq 04	A004	IGH FR3 MiSeq 04	A004
IGH FR1 MiSeq 05	A005	IGH FR2 MiSeq 05	A005	IGH FR3 MiSeq 05	A005
IGH FR1 MiSeq 06	A006	IGH FR2 MiSeq 06	A006	IGH FR3 MiSeq 06	A006
IGH FR1 MiSeq 07	A007	IGH FR2 MiSeq 07	A007	IGH FR3 MiSeq 07	A007
IGH FR1 MiSeq 08	A008	IGH FR2 MiSeq 08	A008	IGH FR3 MiSeq 08	A008
IGH FR1 MiSeq 09	A009	IGH FR2 MiSeq 09	A009	IGH FR3 MiSeq 09	A009
IGH FR1 MiSeq 10	A010	IGH FR2 MiSeq 10	A010	IGH FR3 MiSeq 10	A010
IGH FR1 MiSeq 11	A011	IGH FR2 MiSeq 11	A011	IGH FR3 MiSeq 11	A011
IGH FR1 MiSeq 12	A012	IGH FR2 MiSeq 12	A012	IGH FR3 MiSeq 12	A012
IGH FR1 MiSeq 13	A013	IGH FR2 MiSeq 13	A013	IGH FR3 MiSeq 13	A013
IGH FR1 MiSeq 14	A014	IGH FR2 MiSeq 14	A014	IGH FR3 MiSeq 14	A014
IGH FR1 MiSeq 15	A015	IGH FR2 MiSeq 15	A015	IGH FR3 MiSeq 15	A015
IGH FR1 MiSeq 16	A016	IGH FR2 MiSeq 16	A016	IGH FR3 MiSeq 16	A016
IGH FR1 MiSeq 18	A018	IGH FR2 MiSeq 18	A018	IGH FR3 MiSeq 18	A018
IGH FR1 MiSeq 19	A019	IGH FR2 MiSeq 19	A019	IGH FR3 MiSeq 19	A019
IGH FR1 MiSeq 20	A020	IGH FR2 MiSeq 20	A020	IGH FR3 MiSeq 20	A020
IGH FR1 MiSeq 21	A021	IGH FR2 MiSeq 21	A021	IGH FR3 MiSeq 21	A021
IGH FR1 MiSeq 22	A022	IGH FR2 MiSeq 22	A022	IGH FR3 MiSeq 22	A022
IGH FR1 MiSeq 23	A023	IGH FR2 MiSeq 23	A023	IGH FR3 MiSeq 23	A023
IGH FR1 MiSeq 25	A025	IGH FR2 MiSeq 25	A025	IGH FR3 MiSeq 25	A025
IGH FR1 MiSeq 27	A027	IGH FR2 MiSeq 27	A027	IGH FR3 MiSeq 27	A027

Kit A's contain indices IGH FRX A001 to A008. Panels contain all master mixes listed above.

Controls in Individual FR (1, 2, or 3) Kit A's	Controls in Individual FR (1, 2, or 3) Panels	Controls in Combo FR 1/2/3 Kit A	Controls in Combo FR 1/2/3 Panel
IGH POS (+) Qty. 1	IGH POS (+) Qty 3	IGH POS (+) Qty. 2	IGH POS (+) Qty. 6
NGS NEG (-) Qty. 1	NGS NEG (-) Qty 3	NGS NEG (-) Qty. 2	NGS NEG (-) Qty. 6

## LymphoTrack Dx *IGH* FR1/2/3 Assays continued

### Reagents – Ion S5™ / PGM™ Detection

The LymphoTrack Dx *IGH* FR1/2/3 Assays contain components from respective individual FR Assays.

LymphoTrack Dx <i>IGH</i> FR1 Components		LymphoTrack Dx <i>IGH</i> FR2 Components		LymphoTrack Dx <i>IGH</i> FR3 Components	
Master Mix Name	Index #	Master Mix Name	Index #	Master Mix Name	Index #
<i>IGH</i> FR1 Ion S5/PGM 01	IonXpress_001	<i>IGH</i> FR2 Ion S5/PGM 01	IonXpress_001	<i>IGH</i> FR3 Ion S5/PGM 01	IonXpress_001
<i>IGH</i> FR1 Ion S5/PGM 02	IonXpress_002	<i>IGH</i> FR2 Ion S5/PGM 02	IonXpress_002	<i>IGH</i> FR3 Ion S5/PGM 02	IonXpress_002
<i>IGH</i> FR1 Ion S5/PGM 03	IonXpress_003	<i>IGH</i> FR2 Ion S5/PGM 03	IonXpress_003	<i>IGH</i> FR3 Ion S5/PGM 03	IonXpress_003
<i>IGH</i> FR1 Ion S5/PGM 04	IonXpress_004	<i>IGH</i> FR2 Ion S5/PGM 04	IonXpress_004	<i>IGH</i> FR3 Ion S5/PGM 04	IonXpress_004
<i>IGH</i> FR1 Ion S5/PGM 07	IonXpress_007	<i>IGH</i> FR2 Ion S5/PGM 07	IonXpress_007	<i>IGH</i> FR3 Ion S5/PGM 07	IonXpress_007
<i>IGH</i> FR1 Ion S5/PGM 08	IonXpress_008	<i>IGH</i> FR2 Ion S5/PGM 08	IonXpress_008	<i>IGH</i> FR3 Ion S5/PGM 08	IonXpress_008
<i>IGH</i> FR1 Ion S5/PGM 09	IonXpress_009	<i>IGH</i> FR2 Ion S5/PGM 09	IonXpress_009	<i>IGH</i> FR3 Ion S5/PGM 09	IonXpress_009
<i>IGH</i> FR1 Ion S5/PGM 10	IonXpress_010	<i>IGH</i> FR2 Ion S5/PGM 10	IonXpress_010	<i>IGH</i> FR3 Ion S5/PGM 10	IonXpress_010
<i>IGH</i> FR1 Ion S5/PGM 11	IonXpress_011	<i>IGH</i> FR2 Ion S5/PGM 11	IonXpress_011	<i>IGH</i> FR3 Ion S5/PGM 11	IonXpress_011
<i>IGH</i> FR1 Ion S5/PGM 12	IonXpress_012	<i>IGH</i> FR2 Ion S5/PGM 12	IonXpress_012	<i>IGH</i> FR3 Ion S5/PGM 12	IonXpress_012
<i>IGH</i> FR1 Ion S5/PGM 13	IonXpress_013	<i>IGH</i> FR2 Ion S5/PGM 13	IonXpress_013	<i>IGH</i> FR3 Ion S5/PGM 13	IonXpress_013
<i>IGH</i> FR1 Ion S5/PGM 14	IonXpress_014	<i>IGH</i> FR2 Ion S5/PGM 14	IonXpress_014	<i>IGH</i> FR3 Ion S5/PGM 14	IonXpress_014
Controls in Individual FR (1,2, or 3) Kits			Controls in FR 1/2/3 Kit		
<i>IGH</i> POS (+) Qty. 2			<i>IGH</i> POS (+) Qty. 4		
NGS NEG (-) Qty. 2			NGS NEG (-) Qty. 4		



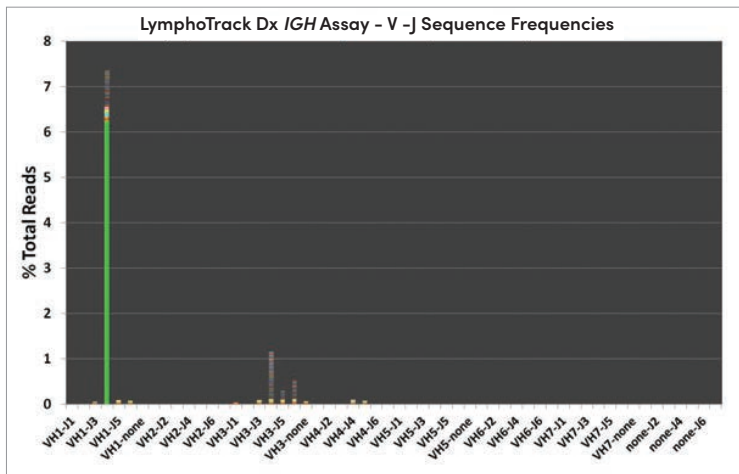

**V-J Sequence Frequencies.** The LymphoTrack Dx Software provides a stacked bar graph depicting the relative frequencies of the 200 most prevalent V<sub>H</sub>-J<sub>H</sub> rearrangements identified in a sample. To learn more about the LymphoTrack Dx software, please refer to the LymphoTrack Dx Bioinformatics Software section.

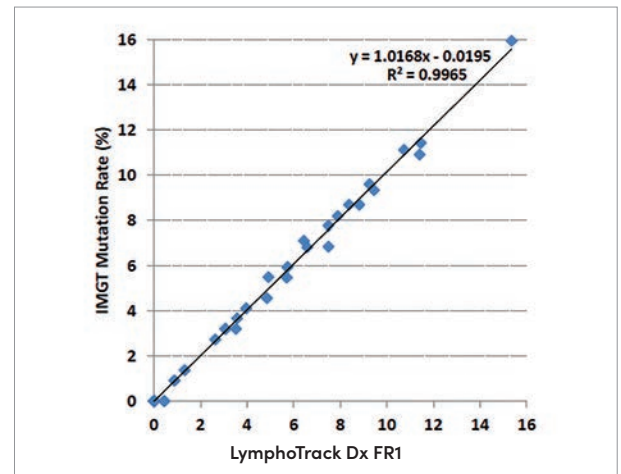

**Comparison of SHM Analysis Methods.** The SHM rate of 51 CLL samples was determined by the LymphoTrack Dx IGH FR1 Assay - MiSeq<sup>®</sup> and analyzed with both the LymphoTrack Dx Software - MiSeq<sup>®</sup> and IMGT analysis.

## Ordering Information

Catalog #	Products	Quantity Components
9-121-0129	LymphoTrack <sup>®</sup> Dx IGH FR1/2/3 Assay Kit A - MiSeq <sup>®</sup>	8 + 8 + 8 indices - 5 sequencing reactions each
9-121-0139	LymphoTrack <sup>®</sup> Dx IGH FR1/2/3 Assay Panel - MiSeq <sup>®</sup>	24 + 24 + 24 indices - 5 sequencing reactions each
9-121-0009	LymphoTrack <sup>®</sup> Dx IGH FR1 Assay Kit A - MiSeq <sup>®</sup>	8 indices - 5 sequencing reactions each
9-121-0039	LymphoTrack <sup>®</sup> Dx IGH FR1 Assay Panel - MiSeq <sup>®</sup>	24 indices - 5 sequencing reactions each
9-121-0089	LymphoTrack <sup>®</sup> Dx IGH FR2 Assay Kit A - MiSeq <sup>®</sup>	8 indices - 5 sequencing reactions each
9-121-0099	LymphoTrack <sup>®</sup> Dx IGH FR2 Assay Panel - MiSeq <sup>®</sup>	24 indices - 5 sequencing reactions each
9-121-0109	LymphoTrack <sup>®</sup> Dx IGH FR3 Assay Kit A - MiSeq <sup>®</sup>	8 indices - 5 sequencing reactions each
9-121-0119	LymphoTrack <sup>®</sup> Dx IGH FR3 Assay Panel - MiSeq <sup>®</sup>	24 indices - 5 sequencing reactions each
9-500-0009	LymphoTrack <sup>®</sup> Dx Software - MiSeq <sup>®</sup>	1 CD complimentary with purchase
9-121-0057	LymphoTrack <sup>®</sup> Dx IGH FR1/2/3 Assay - S5/PGM <sup>™</sup>	12 + 12 + 12 indices - 5 sequencing reactions each
9-121-0007	LymphoTrack <sup>®</sup> Dx IGH FR1 Assay - S5/PGM <sup>™</sup>	12 indices - 5 sequencing reactions each
9-121-0037	LymphoTrack <sup>®</sup> Dx IGH FR2 Assay - S5/PGM <sup>™</sup>	12 indices - 5 sequencing reactions each
9-121-0047	LymphoTrack <sup>®</sup> Dx IGH FR3 Assay - S5/PGM <sup>™</sup>	12 indices - 5 sequencing reactions each
9-500-0007	LymphoTrack <sup>®</sup> Dx Software - S5/PGM <sup>™</sup>	1 CD complimentary with purchase

**CE IVD** These products are CE-IVD assays for *in vitro* diagnostic use.

# LymphoTrack Dx *IGK* Assay

## Assay Description

The LymphoTrack Dx *IGK* Assays for the Illumina<sup>®</sup> MiSeq<sup>®</sup>, or Thermo Fisher Scientific<sup>®</sup> Ion PGM<sup>™</sup> and Ion S5<sup>™</sup> instruments are *in vitro* diagnostic products intended for next-generation sequencing (NGS) based determination of the frequency distribution of *IGK* gene rearrangements in patients suspected of having lymphoproliferative disease. These assays aid in the identification of lymphoproliferative disorders.

## Summary and Explanation of the Test

In contrast to the IdentiClone<sup>®</sup> fragment analysis assays for clonality that utilize two master mixes, these NGS assays contain a single multiplex master mix to target conserved regions of the *IGK* gene locus described in lymphoid malignancies, thereby, reducing sample DNA requirements and simplifying the testing workflow. The LymphoTrack Dx *IGK* master mix primers are also designed with Illumina<sup>®</sup> or Thermo Fisher Scientific adapters and up to 24 different indices. This allows amplicons generated from different indexed *IGK* master mixes to be pooled into a single library for loading onto one MiSeq<sup>®</sup> flow cell, Ion PGM<sup>™</sup> or Ion S5<sup>™</sup> chips.

The associated LymphoTrack Dx Software is capable of sorting complex NGS data by gene target, providing users the ability to reduce per sample testing costs by sequencing amplicons from any LymphoTrack Dx Assay (e.g. *IGH*, *IGK*, *TRB*, *TRG*) at the same time. In addition, the LymphoTrack Dx Software provides an easy and streamlined method for visualization of data and guidelines provided in the instructions for use allow samples to be interpreted for evidence or no evidence of clonality.

Positive clonal and negative polyclonal DNA controls are included in kits.

## Background

The LymphoTrack Dx *IGK* Assays represent a significant improvement over existing fragment analysis clonality assays by providing two important and complementary uses:

1. Detection of initial clonal populations.
2. Identification of sequence information required to track clonal rearrangements in subsequent samples.

The human immunoglobulin kappa (*IGK*) gene locus on chromosome 2 (2p11.2) includes 76 V (variable) region genes spanning 7 subgroups and 5 J (joining) region gene segments upstream of the (Cκ) region.

During lymphoid cell development, antigen receptor genes undergo somatic gene rearrangements. Specifically, during B-cell development, genes encoding *IGK* molecules are assembled from multiple polymorphic gene segments that generate V-J combinations unique in both length and sequence.

In addition, the kappa deleting element ( $K_{de}$ ), approximately 24 kb downstream of the Jκ-Cκ region can also rearrange with Vκ gene segments and the isolated recombination signal sequence in the Jκ-Cκ intron (Jκ-Cκ INTR).

Since leukemias and lymphomas originate from the malignant transformation of individual lymphoid cells, all leukemias and lymphomas generally share one or more cell-specific or "clonal" antigen receptor gene rearrangements. Therefore, tests that detect *IGK* clonal rearrangements can be useful in the study of B- cell malignancies and complement *IGH* testing, as the *IGK* receptor is less susceptible to somatic mutations.

## Specimen Requirement

50 ng of high-quality genomic DNA.

## References

1. EP Rock et al., *J Exp Med* 179 (1): 323-8 (1994).
2. JE Miller et al., *Molecular Diagnostic* 4 (2): 102-117(1999).

## Simplified Representation of the *IGK* Gene



Depicted are the variable region (Vκ) or variable intragenic Jκ-Cκ intron (Jκ-Cκ INTR) genes involved in *IGK* gene rearrangements in addition to the downstream consensus joining region genes (Jκ) or kappa deleting element ( $K_{de}$ ).

## Reagents - MiSeq<sup>®</sup> Detection

Kit A Components		Panel Components (includes all master mixes from Kit A plus the items below)			
Master Mix Name	Index #	Master Mix Name	Index #	Master Mix Name	Index #
IGK MiSeq 01	A001	IGK MiSeq 09	A009	IGK MiSeq 18	A018
IGK MiSeq 02	A002	IGK MiSeq 10	A010	IGK MiSeq 19	A019
IGK MiSeq 03	A003	IGK MiSeq 11	A011	IGK MiSeq 20	A020
IGK MiSeq 04	A004	IGK MiSeq 12	A012	IGK MiSeq 21	A021
IGK MiSeq 05	A005	IGK MiSeq 13	A013	IGK MiSeq 22	A022
IGK MiSeq 06	A006	IGK MiSeq 14	A014	IGK MiSeq 23	A023
IGK MiSeq 07	A007	IGK MiSeq 15	A015	IGK MiSeq 25	A025
IGK MiSeq 08	A008	IGK MiSeq 16	A016	IGK MiSeq 27	A027
Controls		Controls			
IGK POS (+) Qty. 1	NGS NEG (-) Qty. 1	IGK POS (+) Qty. 3	NGS NEG (-) Qty. 3		

## Reagents - Ion S5<sup>™</sup>/PGM<sup>™</sup> Detection

Assay Components			
Master Mix Name	Index #	Master Mix Name	Index #
IGK S5/PGM 01	IonXpress_001	IGK S5/PGM 11	IonXpress_011
IGK S5/PGM 02	IonXpress_002	IGK S5/PGM 12	IonXpress_012
IGK S5/PGM 04	IonXpress_004	IGK S5/PGM 13	IonXpress_013
IGK S5/PGM 08	IonXpress_008	IGK S5/PGM 14	IonXpress_014
IGK S5/PGM 09	IonXpress_009	IGK S5/PGM 16	IonXpress_016
IGK S5/PGM 010	IonXpress_010	IGK S5/PGM 17	IonXpress_017
Controls			
IGK POS (+) Qty. 2		NGS NEG (-) Qty. 2	

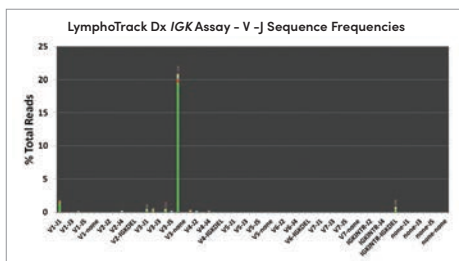

**V-J Sequence Frequencies.** The LymphoTrack Dx Software provides a stacked bar graph depicting the relative frequencies for the most prevalent rearrangements identified in a sample. To learn more about the LymphoTrack Dx software, please refer to the LymphoTrack Dx Bioinformatics Software section.

## Ordering Information

Catalog #	Products	Quantity Components
9-122-0009	LymphoTrack <sup>®</sup> Dx IGK Assay Kit A - MiSeq <sup>®</sup>	8 indices - 5 sequencing reactions each
9-122-0019	LymphoTrack <sup>®</sup> Dx IGK Assay Panel - MiSeq <sup>®</sup>	24 indices - 5 sequencing reactions each
9-500-0009	LymphoTrack <sup>®</sup> Dx Software - MiSeq <sup>®</sup>	1 CD complimentary with purchase
9-122-0007	LymphoTrack <sup>®</sup> Dx IGK Assay - S5/PGM <sup>™</sup>	12 indices - 5 sequencing reactions each
9-500-0007	LymphoTrack <sup>®</sup> Dx Software - S5/PGM <sup>™</sup>	1 CD complimentary with purchase

CE IVD These products are CE-IVD assays for *in vitro* diagnostic use.

# LymphoTrack Dx TRG Assay

## Assay Description

The LymphoTrack Dx TRG Assays for the Illumina<sup>®</sup> MiSeq<sup>®</sup>, Thermo Fisher Scientific<sup>®</sup> Ion PGM<sup>™</sup> or Ion S5<sup>™</sup> instruments are *in vitro* diagnostic products intended for next-generation sequencing (NGS) based determination of the frequency distribution of TRG gene rearrangements in patients suspected with having lymphoproliferative disease. These assays aid in the identification of lymphoproliferative disorders.

## Summary and Explanation of the Test

These assays utilize a single multiplex master mix to target conserved V and J regions of the human T-cell receptor gamma (TRG) gene that are described in lymphoid malignancies. Primers are designed with Illumina<sup>®</sup> or Thermo Fisher Scientific adapters and up to 24 different indices; thereby allowing amplicons generated from different TRG master mixes to be pooled together for sequencing on a single MiSeq<sup>®</sup> flow cell, or Ion PGM<sup>™</sup> or Ion S5<sup>™</sup> chip.

The associated LymphoTrack Dx Software sorts complex NGS data by gene target, providing users the ability to reduce per sample testing costs by sequencing amplicons generated with any LymphoTrack Dx Assay (e.g. IGH, IGK, TRB, TRG) at the same time. In addition, the LymphoTrack Dx Software provides an easy and streamlined method for data visualization and guidelines provided in the instructions for use allow samples to be interpreted for evidence or no evidence of clonality.

Positive clonal and negative polyclonal DNA controls are included in kits.

## Background

The LymphoTrack Dx TRG Assays represent a significant improvement over existing fragment analysis clonality assays by providing two important and complementary uses:

1. Detection of initial clonal populations.
2. Identification of sequence information required to track clonal rearrangements in subsequent samples.

The TRG gene locus on chromosome 7 (7q14) includes 14 V (variable region) genes (Group I, II, III, and IV), 5 J (joining region) gene segments, and 2 C (constant region) genes spread over 200 kilobases.

During development of lymphoid cells, antigen receptor genes undergo somatic gene rearrangements. Specifically during T-cell development, genes encoding TRG molecules are assembled from multiple polymorphic gene segments that undergo rearrangement generating V-J combinations unique in both length and sequence. Since leukemias and lymphomas originate from the malignant transformation of individual lymphoid cells, all leukemias and lymphomas generally share one or more cell-specific or “clonal” antigen receptor gene rearrangement. Therefore, tests that detect TRG clonal rearrangements can be useful in the study of B- and T-cell malignancies.

## Specimen Requirement

50 ng of high-quality genomic DNA.

## References

1. S Tonegawa. *Nature* 302: 575-581 (1983).
2. JE Miller et al., *Molecular Genetic Pathology* (2nd ed.). Springer Science & Business Media. 2013: 30.2.7.13.

## Simplified Representation of the TRG Gene



Depicted are the variable region (V) genes and downstream consensus joining region genes (J) that are involved in TRG gene rearrangements.

## Reagents - MiSeq<sup>®</sup> Detection

Kit A Components		Panel Components (includes all master mixes from Kit A plus the items below)			
Master Mix Name	Index #	Master Mix Name	Index #	Master Mix Name	Index #
TRG MiSeq 01	A001	TRG MiSeq 09	A009	TRG MiSeq 18	A018
TRG MiSeq 02	A002	TRG MiSeq 10	A010	TRG MiSeq 19	A019
TRG MiSeq 03	A003	TRG MiSeq 11	A011	TRG MiSeq 20	A020
TRG MiSeq 04	A004	TRG MiSeq 12	A012	TRG MiSeq 21	A021
TRG MiSeq 05	A005	TRG MiSeq 13	A013	TRG MiSeq 22	A022
TRG MiSeq 06	A006	TRG MiSeq 14	A014	TRG MiSeq 23	A023
TRG MiSeq 07	A007	TRG MiSeq 15	A015	TRG MiSeq 25	A025
TRG MiSeq 08	A008	TRG MiSeq 16	A016	TRG MiSeq 27	A027
Controls		Controls			
TRG POS (+) Qty. 1	NGS NEG (-) Qty. 1	TRG POS (+) Qty. 3	NGS NEG (-) Qty. 3		

## Reagents - Ion S5<sup>™</sup>/PGM<sup>™</sup> Detection

Assay components					
Master Mix Name	Index #	Master Mix Name	Index #	Master Mix Name	Index #
TRG S5/PGM 01	IonXpress_001	TRG S5/PGM 07	IonXpress_007	TRG S5/PGM 11	IonXpress_011
TRG S5/PGM 02	IonXpress_002	TRG S5/PGM 08	IonXpress_008	TRG S5/PGM 12	IonXpress_012
TRG S5/PGM 03	IonXpress_003	TRG S5/PGM 09	IonXpress_009	TRG S5/PGM 13	IonXpress_013
TRG S5/PGM 04	IonXpress_004	TRG S5/PGM 10	IonXpress_010	TRG S5/PGM 14	IonXpress_014
Controls					
TRG POS (+) Qty. 2			NGS NEG (-) Qty. 2		

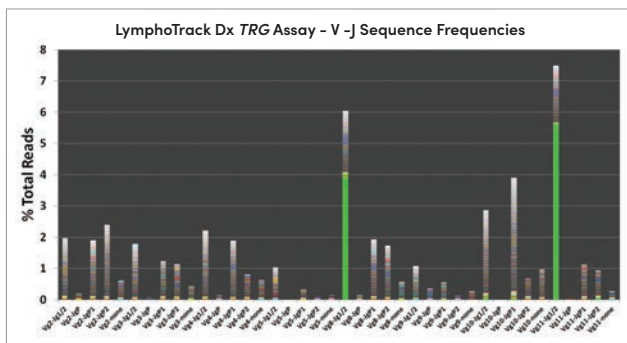

**V-J Sequence Frequencies.** The LymphoTrack Dx bioinformatics software provides PDF reports which include Top 10 Merged Read Summary as well as a stacked bar graph depicting the relative frequencies of the V-J rearrangements identified in the sample. To learn more about the LymphoTrack Dx software, please refer to the LymphoTrack Dx Bioinformatics Software section.

## Ordering Information

Catalog #	Products	Quantity Components
9-227-0019	LymphoTrack <sup>®</sup> Dx TRG Assay Kit A - MiSeq <sup>®</sup>	8 indices - 5 sequencing reactions each
9-227-0009	LymphoTrack <sup>®</sup> Dx TRG Assay Panel - MiSeq <sup>®</sup>	24 indices - 5 sequencing reactions each
9-500-0009	LymphoTrack <sup>®</sup> Dx Software - MiSeq <sup>®</sup>	1 CD complimentary with purchase
9-227-0007	LymphoTrack <sup>®</sup> Dx TRG Assay - S5/PGM <sup>™</sup>	12 indices - 5 sequencing reactions each
9-500-0007	LymphoTrack <sup>®</sup> Dx Software - S5/PGM <sup>™</sup>	1 CD complimentary with purchase

## LymphoTrack Dx TRB Assay

### Assay Description

The LymphoTrack<sup>®</sup> Dx TRB Assay is an *in vitro* diagnostic product intended for next-generation sequencing (NGS) for the Illumina MiSeq<sup>®</sup> instrument. The assay will determine the frequency distribution of TRB V $\beta$ -J $\beta$  gene rearrangements in patients suspected of having lymphoproliferative disease. This assay aids in the identification of lymphoproliferative disorders.

### Summary and Explanation of the Test

In contrast to the IdentiClone<sup>®</sup> fragment analysis assays for clonality that utilizes three master mixes, this NGS-based assay contains a single multiplex master mix to target conserved V and J regions of the TRB gene locus described in lymphoid malignancies, thereby, reducing sample DNA requirements and simplifying the testing workflow. The LymphoTrack Dx TRB master mix primers are designed with Illumina<sup>®</sup> adapters and 8 (Kit A) or 24 (Panel) different indices. This allows amplicons generated from different indexed TRB master mixes to be pooled into a single library for loading onto one MiSeq<sup>®</sup> flow cell.

The associated LymphoTrack Dx Software is capable of sorting complex NGS data by gene target, offering a second layer of multiplexing. This provides users the ability to reduce per sample testing costs by sequencing amplicons from any LymphoTrack Dx MiSeq<sup>®</sup> Assay (e.g. TRB, TRG, IGH, IGK) at the same time. In addition, the LymphoTrack Dx Software provides an easy and streamlined method for visualization of data. Guidelines to interpret samples for evidence or no evidence of clonality are included in the instructions for use provided with each kit.

Positive clonal and negative polyclonal DNA controls are included in kits.

### Background

The LymphoTrack Dx TRB Assays represent a significant improvement over fragment analysis methods for clonality testing by providing two important and complementary uses:

1. Detection of initial clonal populations.
2. Identification of sequence information required to track clonal rearrangements in subsequent samples.

Analysis of the rearranged TRB locus increases the probability of identifying T cell receptor gene rearrangements, as compared to testing for TRG gene rearrangements only. As a result, combining the analysis of TRB and TRG loci increases the sensitivity of clonality detection.

The human T-cell receptor beta (TRB) gene locus on chromosome 7 (7q34) includes 65 V $\beta$  (variable) gene segments, followed by two separate clusters of genes each containing a D $\beta$  (diversity) gene, several J $\beta$  (joining) genes, and a C $\beta$  (constant) region spread over 685 kilobases. The 2 C $\beta$  genes, TRBC1 and TRBC2, encode highly homologous products with no functional difference.

During lymphoid cell development, antigen receptor genes undergo somatic gene rearrangements. Specifically, during T-cell development genes encoding TRB molecules are assembled from multiple polymorphic gene segments that generate V $\beta$  - D $\beta$  - J $\beta$  combinations unique in both length and sequence.

Since leukemias and lymphomas originate from the malignant transformation of individual lymphoid cells, all leukemias and lymphomas generally share one or more cell-specific or "clonal" antigen receptor gene rearrangements. Therefore, tests that detect TRB clonal rearrangements can be useful in the study of B- and T-cell malignancies.

### Specimen Requirement

50 ng of high-quality genomic DNA.

### References

1. EP Rock et al., *J Exp Med* 179 (1): 323-8 (1994).
2. JE Miller et al., *Molecular Genetic Pathology* (2nd ed.). Springer

---

### Simplified Representation of the TRB Gene



Depicted are the variable (V $\beta$ ), diversity (D $\beta$ ), and joining (J $\beta$ ) gene regions involved in TRB gene rearrangements, in addition to the downstream consensus (C $\beta$ ) gene regions.

## Reagents - MiSeq<sup>®</sup> Detection

Kit A Components		Panel Components (includes all master mixes from Kit A plus the items below)			
Master Mix Name	Index #	Master Mix Name	Index #	Master Mix Name	Index #
TRB MiSeq 01	A001	TRB MiSeq 09	A009	TRB MiSeq 18	A018
TRB MiSeq 02	A002	TRB MiSeq 10	A010	TRB MiSeq 19	A019
TRB MiSeq 03	A003	TRB MiSeq 11	A011	TRB MiSeq 20	A020
TRB MiSeq 04	A004	TRB MiSeq 12	A012	TRB MiSeq 21	A021
TRB MiSeq 05	A005	TRB MiSeq 13	A013	TRB MiSeq 22	A022
TRB MiSeq 06	A006	TRB MiSeq 14	A014	TRB MiSeq 23	A023
TRB MiSeq 07	A007	TRB MiSeq 15	A015	TRB MiSeq 25	A025
TRB MiSeq 08	A008	TRB MiSeq 16	A016	TRB MiSeq 27	A027
Controls		Controls			
TRB POS (+) Qty. 1	NGS NEG (-) Qty. 1	TRB POS (+) Qty. 3		NGS NEG (-) Qty. 3	

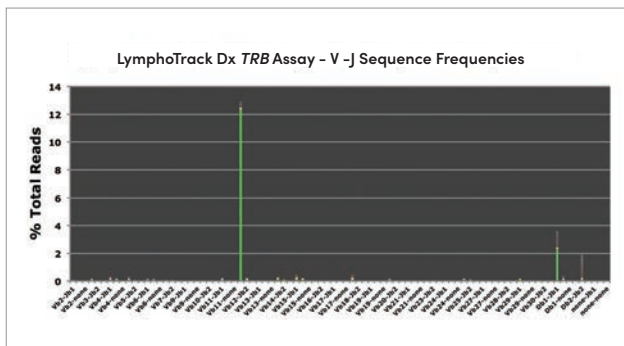

**V-J Sequence Frequencies.** The LymphoTrack Dx bioinformatics software provides a stacked bar graph depicting the relative frequencies for the 200 most prevalent rearrangements sequenced and identified in the sample. To learn more about the LymphoTrack Dx software, please refer to the LymphoTrack Dx Bioinformatics Software section.

## Ordering Information

Catalog #	Products	Quantity Components
9-225-0009	LymphoTrack <sup>®</sup> Dx TRB Assay Kit A - MiSeq <sup>®</sup>	8 indices - 5 sequencing reactions each
9-225-0019	LymphoTrack <sup>®</sup> Dx TRB Assay Panel - MiSeq <sup>®</sup>	24 indices - 5 sequencing reactions each
9-500-0009	LymphoTrack <sup>®</sup> Dx Software - MiSeq <sup>®</sup>	1 CD complimentary with purchase

## LymphoTrack Dx Bioinformatics Software

### Software Use

The LymphoTrack Dx Bioinformatics Software package is provided with each LymphoTrack Dx Assay to analyze raw FASTQ files for clonality analysis of single or multiple target data sets (*IGHV* Leader, *IGH* FR1, *IGH* FR2, *IGH* FR3, *IGK*, *TRB*, or *TRG*). For data generated with LymphoTrack Dx *IGHV* Leader or *IGH* FR1 Assays, the software provides additional information, including the rate of somatic hypermutation and whether a clone would be functional based upon the presence of a premature stop codon. The software can also predict whether an open reading frame would be in- or out-of-frame.

The provided software is composed of two distinct parts:

1. A bioinformatics Data Analysis Application
2. Microsoft Excel<sup>®</sup> Data Visualization spreadsheets and automated Sample-to-PDF Reports for streamlined data analysis for VJ usage and VJ sequence frequency graphs.

### Minimum Software Requirements

- Processor: Intel Core 2 Duo or newer CPU recommended.
- Hard Drive: At least 80 GB of free disk space is required; 250 GB recommended.
- RAM: 4 GB required; 8 GB or more recommended.

- Operating System: Windows 7 (64-bit) is required.
- Java 8 for 64-bit operating systems or higher (Java configured for 32-bit operating systems is not compatible with the LymphoTrack Dx Software – MiSeq or LymphoTrack Dx Software – S5/PGM). The most recent version of Java can be downloaded directly from Oracle at <http://www.java.com/>.
- A PDF reader, such as Adobe Acrobat Reader, to visualize data reports generated by the LymphoTrack Reporter.
- Microsoft Office Excel 2007, 2010, or 2013 with Macro support enabled is required for data visualization.
- A CD-ROM drive.
- The LymphoTrack Dx Software – MiSeq has been validated for use with Windows 7 configured for English (United States) language and default display size settings, and Microsoft Excel 2007/2010/2013 for alternate data visualization. Use of other Windows/Excel versions and/or language/display size settings may not be compatible.
- The LymphoTrack Dx Software – S5/PGM has been validated for use with Microsoft Excel 2007/2010/2013/2016 and Windows 7 or Windows 10 configured for English (United States) language and default display size settings, and for alternate data visualization. Use of other Windows/Excel versions and/or language/display size settings may not be compatible.

\* If a CD-ROM drive is not available, please contact us at: [support@invivoscribe.com](mailto:support@invivoscribe.com)

### Sequence Frequency Graph

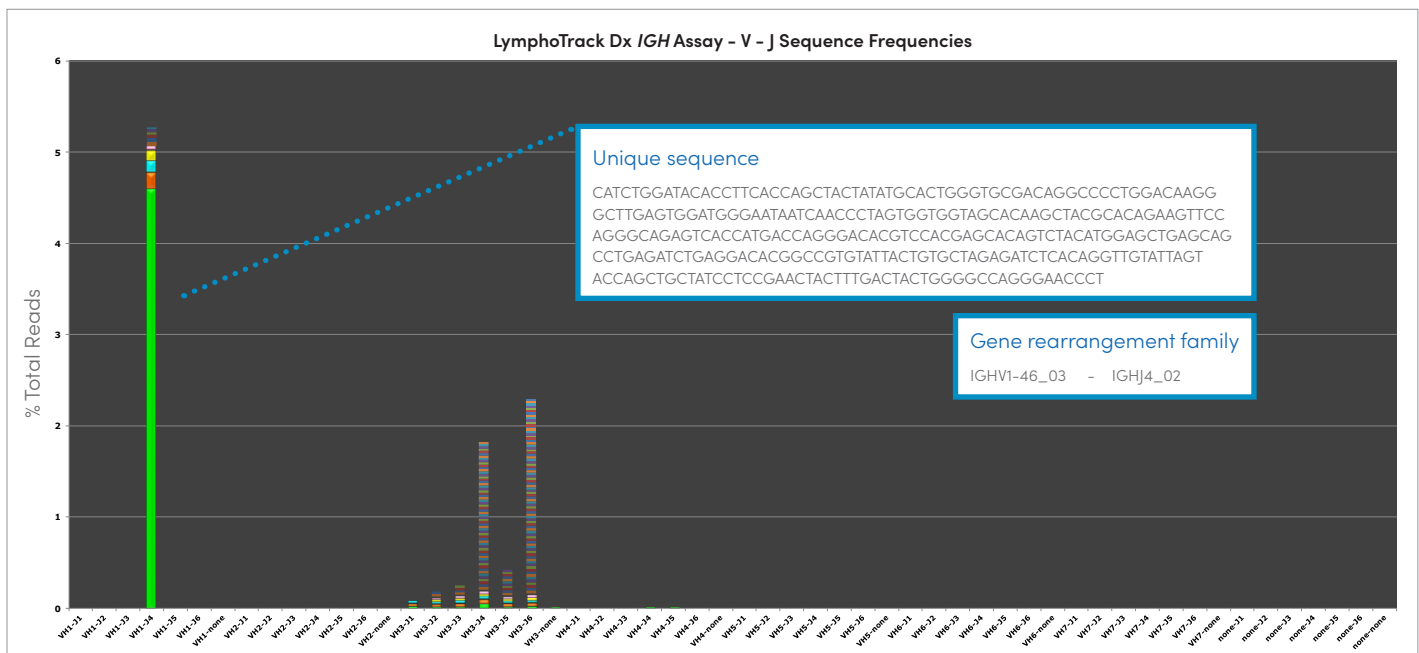

The stacked bar graph depicts the top 200 sequencing reads for a sample. Each individual colored bar represents a unique population of cells. Different colors stacked at the same point on the x-axis represent unique sequences that utilize the same V and J gene families. The amplicons of these products vary in sequence and may also vary in product size.



## Sequencing Summary

Using the merged read summary, along with the easy to follow flow charts in the accompanying LymphoTrack Dx Assay instructions for use (IFU), interpretation is quick and easy.

Sample Name												
Total reads = 32,458												
Rank	Sequence	Length	Merge count	V-gene	J-gene	% Total reads	Cumulative %	Mutation rate partial V-gene (%)	In-frame (Y/N)	No stop codon (Y/N)	V-coverage	
1	TTCTCGTGGTG	455	29603	IGHV4-59_08	IGHJ4_02	9.93	9.93	11.26	Y	Y	98.63	
2	CTCGCCCTCCT	463	205	IGHV5-51_01	IGHJ4_02	0.07	9.99	0.00	Y	Y	99.66	
3	GGTTTTCTTG	484	201	IGHV3-7_01	IGHJ4_02	0.07	10.06	7.77	Y	Y	100.00	
4	CTCGCCCTCCT	463	185	IGHV5-51_01	IGHJ5_02	0.06	10.12	6.08	Y	Y	99.32	
5	CTCGCCCTCCT	469	170	IGHV5-51_01	IGHJ4_02	0.06	10.18	0.00	Y	Y	99.32	
6	CTCGCCCTCCT	466	160	IGHV5-51_01	IGHJ4_02	0.05	10.23	0.00	Y	Y	99.66	
7	CTGCTGCTGAC	460	159	IGHV2-5_10	IGHJ5_02	0.05	10.29	8.08	Y	Y	97.64	
8	GGTTTTCTTG	493	156	IGHV3-48_02	IGHJ6_02	0.05	10.34	3.72	Y	Y	98.99	
9	CTCGCCCTCCT	334	153	IGHV5-51_02	IGHJ2_01	0.05	10.39	3.72	Y	N	27.70	
10	CTCGCCCTCCT	334	152	IGHV5-51_02	IGHJ2_01	0.05	10.44	3.38	Y	N	26.01	

- The sample name is clearly identified and the total number of reads (= Read Depth) generated for the sample is provided. Following the IFU, it is easy to determine whether the data generated for a sample can be assessed for the presence or absence of clonality.
- The sequence of clonal populations is provided and populations are ranked from most abundant to least prevalent. Sequences that differ by 1-2 basepairs are automatically merged to account for possible sequencing errors and to improve the accuracy and ease of sample interpretation.
- Sequences are aligned with reference genes to allow for easy identification of specific types of gene rearrangements such as *IGHV3-21*, which is characteristic of some CLL cases and correlates with a poor prognosis.
- The percentage that a unique sequence contributes to the total number of reads for a sample is calculated. Following the guidelines in the IFU, samples can be interpreted for the evidence indicating the presence or absence of clonality.
- For the LymphoTrack Dx *IGHV* Leader and *IGH* FR1 Assays, the somatic hypermutation status of a sequence is automatically calculated by comparing the identified sequence with a germline reference. In addition, predictions on whether the sequence would be functional can be drawn by the provided information regarding the presence of a premature stop codon or an open reading frame that is out-of-frame.

## Ordering Information

Catalog #	Products	Quantity Components
9-500-0009	LymphoTrack <sup>®</sup> Dx Software - MiSeq <sup>®</sup>	1 CD complimentary with kit purchase
9-500-0007	LymphoTrack <sup>®</sup> Dx Software - S5/PGM <sup>™</sup>	1 CD complimentary with kit purchase



## Next-Generation Sequencing (NGS) RUO Assays

### Key Benefits

- » One-step PCR for amplicon and library generation
- » Identify and assess mutation status of B- and T-cell gene rearrangements
- » Sequence amplicons from any LymphoTrack kit together
- » Included bioinformatics software for easy analysis and interpretation
- » Same reagents for clonality, somatic hypermutation (SHM), minimal residual disease (MRD) testing, and tracking/monitoring of immunotherapy constructs

36 / LymphoTrack *IGH* Leader Somatic Hypermutation Assay

44 / LymphoTrack *TRG* Assays

38 / LymphoTrack *IGH* FR1/2/3 Assays

46 / LymphoTrack *TRB* Assay

42 / LymphoTrack *IGK* Assays

48 / LymphoTrack Bioinformatics Software

#### WARRANTY AND LIABILITY

Invivoscribe® (Invivoscribe®) is committed to providing the highest quality products. Invivoscribe® warrants that the products meet or exceed the performance standards described in the Instructions For Use, as to products with such an insert. If a product is covered by product specifications and does not perform as specified, our policy is to replace the product or credit the full purchase price. No other warranties of any kind, expressed or implied, are provided by Invivoscribe®. Invivoscribe® liability shall not exceed the purchase price of the product. Invivoscribe® shall have no liability for direct, indirect, consequential or incidental damages arising from the use, results of use, or inability to use its products; product efficacy under purchaser controlled conditions in purchaser's laboratory must be established and continually monitored through purchaser defined and controlled processes including but not limited to testing of positive, negative, and blank controls every time a sample is tested. Ordering, acceptance and use of product constitutes purchaser acceptance of sole responsibility for assuring product efficacy and purchaser agreement to the limitation of liability set forth in this paragraph.

NOTICE: Many of the products listed in the section that follows may be covered by one or more of the following patents and patent applications owned by or exclusively licensed to Invivoscribe, Inc.: United States Patent Number 7,785,783, United States Patent Number 8,859,748, United States Patent 10,280,462, European Patent Number EP 1549764B1 (validated in 16 countries, and augmented by related European Patents Numbered EP2418287A3 and EP 2460889A3), Japanese Patent Number JP04708029B2, Japanese Patent Application Number 2006-529437, Brazil Patent Application Number PI0410283.5, Canadian Patent Number CA2525122, Indian Patent Number IN243620, Mexican Patent Number MX286493, Chinese Patent Number CN1806051, and Korean Patent Number 101215194.

These products use nucleic acid amplification methods such as Polymerase Chain Reaction (PCR). Any necessary license to practice amplification methods or to use reagents, amplification enzymes or equipment covered by third party patents is the responsibility of the user and no such license is granted by Invivoscribe, Inc., expressly or by implication.



LymphoTrack Assay kits are designed for the identification of gene rearrangements in hematologic samples utilizing next-generation sequencing (NGS) technologies.

These assays take advantage of the wealth and depth of NGS data generated with either the Illumina® MiSeq® or the Thermo Fisher Scientific® Ion PGM™ and Ion S5™ platforms. They offer significant improvements over conventional clonality testing methods, by providing the distribution of gene rearrangements, DNA sequences, the mutational status (*IGH* only), and the ability to track specific gene rearrangements all with the same workflow.

Primers included in the master mixes are designed with Illumina® adapters and indices (8 or 24 indices configurations for a total possible 24 or \*48 unique indices [\*FR1 only] per framework kits) or Thermo Fisher adapters and indices (12 indices per framework kits). By offering multiple kit configurations (8-or-24 indices for MiSeq®, 12 for Ion S5/PGM™), Invivoscribe further provides laboratories the ability to choose the optimal kit for their sample throughput and read-depth requirements. Testing costs can be reduced by sequencing in a single run, with the possibility to combine: a) samples with up to 48 different indices and b) amplicons from other LymphoTrack Assays.

Research Use Only (RUO) assays are not for sale in Europe and other global markets where equivalent CE-IVD assays are available and registered with the appropriate regulatory agencies. For more information regarding the CE-marked LymphoTrack® Dx Assays, please refer to the preceding pages.

# LymphoTrack IGHV Leader Somatic Hypermutation Assay

## Assay Uses

This research use only (RUO) assay for next-generation sequencing (NGS), identifies clonal IGH V<sub>H</sub>-J<sub>H</sub> rearrangements, the associated V<sub>H</sub>-J<sub>H</sub> DNA sequences, and the frequency distribution of V<sub>H</sub> region and J<sub>H</sub> region segment utilization. The assay also uses the Illumina<sup>®</sup> MiSeq<sup>®</sup> platform to define the extent of somatic hypermutation (SHM) present in the IGHV gene of analyzed samples. If you would like to test for IGHV somatic hypermutation using the Thermo Fisher<sup>®</sup> Ion PGM<sup>™</sup> or Ion S5<sup>™</sup> platform please refer to the LymphoTrack IGH FR1 Assay (7-121-0007).

## Summary and Explanation of the Test

The LymphoTrack IGHV Leader Somatic Hypermutation Assay for NGS provides significant improvements over clonality assays using fragment analysis and Sanger sequencing. The assay efficiently detects the majority of IGH gene rearrangements using a single multiplex master mix, identifies the DNA sequence specific for each clonal gene rearrangement, and calculates the degree of SHM for each sample.

The master mixes included in this assay target the Leader (V<sub>H</sub>L) and the joining (J<sub>H</sub>) gene regions of IGH and are designed with Illumina<sup>®</sup> adapters and indices (8 included in Kit A and 24 included in Panels). Including adapters and indices in the primer design allows for a one-step PCR approach to generate sequence-ready amplicons, followed by direct pooling of samples for sequencing on a Illumina<sup>®</sup> MiSeq<sup>®</sup> flow cell.

The included LymphoTrack bioinformatics software enables simplified analysis and visualization of data generated from this assay.

Positive (clonal positive, SHM negative), negative (polyclonal), and SHM positive (clonal positive, SHM positive) controls are included in the kit. Primers included in the master mixes are designed with Illumina<sup>®</sup> adapters and indices (8 or 24 indices per framework kits). This allows for a one-step PCR reaction to generate sequence-ready amplicons and pooling of several different samples on the same Illumina<sup>®</sup> MiSeq<sup>®</sup> flow cell. The LymphoTrack bioinformatics software enables easy analysis and visualization of data and the LymphoTrack MRD Software allows sequences to be tracked in subsequent samples. Please see the LymphoTrack MRD software section to learn how the LymphoTrack Assays can be applied to MRD studies, or email [marketing@invivoscribe.com](mailto:marketing@invivoscribe.com).

## Background

The human immunoglobulin heavy chain (IGH) gene locus on chromosome 14 (14q32.3) includes 46 - 52 functional and 30 nonfunctional variable (V<sub>H</sub>) gene segments, 27 functional diversity (D<sub>H</sub>) gene segments, and 6 functional joining (J<sub>H</sub>) gene segments spread over 1250 kilobases.

During B-cell development, genes encoding the IGH molecules are assembled from multiple polymorphic gene segments that undergo rearrangements and selection, generating V<sub>H</sub>-D<sub>H</sub>-J<sub>H</sub> combinations that are unique in both length and sequence for each cell.

Since leukemias and lymphomas originate from the malignant transformation of individual lymphoid cells, all leukemias and lymphomas generally share one or more cell-specific or "clonal" antigen receptor gene rearrangements. Therefore, tests that detect IGH clonal rearrangements can be useful in the study of B-cell malignancies. An additional level of diversity is generated in the antigen receptors by somatic point mutations in the variable regions and this mutation status provides important prognostic information for chronic lymphocytic leukemia (CLL) and small lymphocytic lymphoma (SLL). In addition, NGS methods can improve disease stratification and elucidate subclone gene profiles.

## Specimen Requirement

50 ng of high-quality genomic DNA.

## References

1. B Stamatopoulos et al., *Leukemia* 4:837-845 (2017).
2. F Davi et al., *Leukemia* 22: 212-214 (2008).
3. JE Miller et al., *Molecular Genetic Pathology* (2nd ed.). Springer Science & Business Media. 2013: 302.2.713 and 30.2.718.
4. KJ Trainor et al., *Blood* 75: 2220-2222 (1990).
5. P Ghia et al., *Leukemia* 21: 2-3 (2007).
6. P Ghia et al., *Blood* 105: 1678-685 (2005).
7. S Tonegawa. *Nature* 302: 575-581 (1983).



Simple representation of the organization of the immunoglobulin heavy chain (IGH) gene on chromosome 14. Depicted are the variable region (V<sub>H</sub>) genes and downstream consensus joining region genes (J<sub>H</sub>) that are involved in rearrangements. Upstream of the variable gene segments, the leader sequence (V<sub>H</sub>L) is also depicted. Diversity region genes are not depicted.

## Reagents - MiSeq<sup>®</sup> Detection

Kit A Components		Panel Components (includes all master mixes from Kit A plus the items below)			
Master Mix Name	Index #	Master Mix Name	Index #	Master Mix Name	Index #
<i>IGH</i> Leader MiSeq 01	A001	<i>IGH</i> Leader MiSeq 09	A009	<i>IGH</i> Leader MiSeq 18	A018
<i>IGH</i> Leader MiSeq 02	A002	<i>IGH</i> Leader MiSeq 10	A010	<i>IGH</i> Leader MiSeq 19	A019
<i>IGH</i> Leader MiSeq 03	A003	<i>IGH</i> Leader MiSeq 11	A011	<i>IGH</i> Leader MiSeq 20	A020
<i>IGH</i> Leader MiSeq 04	A004	<i>IGH</i> Leader MiSeq 12	A012	<i>IGH</i> Leader MiSeq 21	A021
<i>IGH</i> Leader MiSeq 05	A005	<i>IGH</i> Leader MiSeq 13	A013	<i>IGH</i> Leader MiSeq 22	A022
<i>IGH</i> Leader MiSeq 06	A006	<i>IGH</i> Leader MiSeq 14	A014	<i>IGH</i> Leader MiSeq 23	A023
<i>IGH</i> Leader MiSeq 07	A007	<i>IGH</i> Leader MiSeq 15	A015	<i>IGH</i> Leader MiSeq 25	A025
<i>IGH</i> Leader MiSeq 08	A008	<i>IGH</i> Leader MiSeq 16	A016	<i>IGH</i> Leader MiSeq 27	A027
<b>Controls</b>		<b>Controls</b>			
<i>IGH</i> SHM POS (+) Qty. 1		<i>IGH</i> SHM POS (+) Qty. 3			
<i>IGH</i> POS (+) Qty. 1		<i>IGH</i> POS (+) Qty. 3			
NGS NEG (-) Qty. 1		NGS NEG (-) Qty. 3			

Rank	Sequence	Length	Merge count	V-gene	J-gene	% Total reads	Cumulative %	Mutation rate partial V-gene (%)	In-frame (Y/N)	No stop codon (Y/N)	V-coverage
1	TTCTCGTGGTG	455	29603	IGHV4-59_08	IGHJ4_02	9.93	9.93	11.26	Y	Y	98.63
2	CTCGCCCTCCT	463	205	IGHV5-51_01	IGHJ4_02	0.07	9.99	0.00	Y	Y	99.66
3	GGTTTTCTTG	484	201	IGHV3-7_01	IGHJ4_02	0.07	10.06	7.77	Y	Y	100.00
4	CTCGCCCTCCT	463	185	IGHV5-51_01	IGHJ5_02	0.06	10.12	6.08	Y	Y	99.32
5	CTCGCCCTCCT	469	170	IGHV5-51_01	IGHJ4_02	0.06	10.18	0.00	Y	Y	99.32
6	CTCGCCCTCCT	466	160	IGHV5-51_01	IGHJ4_02	0.05	10.23	0.00	Y	Y	99.66
7	CTGCTGCTGAC	460	159	IGHV2-5_10	IGHJ5_02	0.05	10.29	8.08	Y	Y	97.64
8	GGTTTTCTTG	493	156	IGHV3-48_02	IGHJ6_02	0.05	10.34	3.72	Y	Y	98.99
9	CTCGCCCTCCT	334	153	IGHV5-51_02	IGHJ2_01	0.05	10.39	3.72	Y	N	27.70
10	CTCGCCCTCCT	334	152	IGHV5-51_02	IGHJ2_01	0.05	10.44	3.38	Y	N	26.01

Example Data. Depicted are the top 10 sequences from a read summary generated by the LymphoTrack Software - MiSeq<sup>®</sup>. Highlighted columns represent fields that are unique to SHM analysis and include the SHM mutation rate and predictions pertaining to whether a sequence is in-frame or contains a premature stop codon. To learn more about the LymphoTrack software, please refer to the LymphoTrack Bioinformatics Software section.

## Ordering Information

Catalog #	Products	Quantity Components
7-121-0059	LymphoTrack <sup>®</sup> <i>IGHV</i> Leader Somatic Hypermutation Assay Kit A - MiSeq <sup>®</sup>	8 indices - 5 sequencing reactions each
7-121-0069	LymphoTrack <sup>®</sup> <i>IGHV</i> Leader Somatic Hypermutation Assay Panel - MiSeq <sup>®</sup>	24 indices - 5 sequencing reactions each
7-500-0009	LymphoTrack <sup>®</sup> Software - MiSeq <sup>®</sup>	1 CD complimentary with purchase

# LymphoTrack IGH FR1/FR2/FR3 Assays

## Assay Uses

These research use only (RUO) assays for next-generation sequencing (NGS), identify clonal IGH V<sub>H</sub>-J<sub>H</sub> rearrangements, the associated V<sub>H</sub>-J<sub>H</sub> region DNA sequences, the frequency distribution of V<sub>H</sub> region and J<sub>H</sub> region segment utilization. The LymphoTrack FR1 can also identify the degree of somatic hypermutation (SHM) of rearranged genes using the Illumina<sup>®</sup> MiSeq<sup>®</sup>, Thermo Fisher Scientific<sup>®</sup> Ion PGM<sup>™</sup> or Ion S5<sup>™</sup>. The LymphoTrack IGH FR1, IGH FR2, and IGH FR3 Assays contain primers that target the conserved framework 1 (FR1), framework 2 (FR2), and framework 3 (FR3) regions, respectively. The LymphoTrack IGH FR1/2/3 Assay kits contain the master mixes of all three frameworks.

## Summary and Explanation of the Test

The LymphoTrack IGH Assays represent a significant improvement over clonality assays that utilize fragment analysis by providing four important and complementary uses:

1. Detection of clonal populations.
2. Identification of sequence information and V<sub>H</sub>-J<sub>H</sub> segment utilization.
3. The LymphoTrack IGH FR1 Assays provide the degree of SHM of the immunoglobulin variable heavy chain (IGHV).
4. The ability to track sequences in subsequent samples with the Invivoscribe LymphoTrack MRD Software.

Primers included in the master mixes are designed with Illumina<sup>®</sup> adapters and indices (8 included in Kit A, 24 included in the Panel, and an independent 24 included in the Panel B) or Thermo Fisher adaptors and indices (12 indices per framework kits). This allows for a one-step PCR reaction to generate sequence-ready amplicons and pooling of several different samples on the same Illumina<sup>®</sup> MiSeq<sup>®</sup> cell, Ion S5 or Ion PGM chip. The LymphoTrack bioinformatics software enables easy analysis and visualization of data and the LymphoTrack MRD Software allows sequences to be tracked in subsequent samples. Please see the LymphoTrack MRD software section to learn how the LymphoTrack Assays can be applied to MRD studies, or email [marketing@invivoscribe.com](mailto:marketing@invivoscribe.com).

Positive clonal (SHM negative) and negative polyclonal DNA controls are included in kits. A clonal SHM positive control can be purchased separately (4-088-0008).

## Background

The human immunoglobulin heavy chain (IGH) gene locus on chromosome 14 (14q32.3) includes 46-52 functional and 30 nonfunctional variable (V<sub>H</sub>) gene segments, 27 functional diversity (D<sub>H</sub>) gene segments, and 6 functional joining (J<sub>H</sub>) gene segments spread over 1250 kilobases.

During development of lymphoid cells, the antigen receptor genes go through somatic gene rearrangements. For example, during B-cell development, genes encoding the IGH molecules are assembled from multiple polymorphic gene segments that undergo rearrangements and selection, generating V<sub>H</sub>-D<sub>H</sub>-J<sub>H</sub> combinations. Since leukemias and lymphomas originate from the malignant transformation of individual lymphoid cells, all leukemias and lymphomas generally share one or more cell-specific or "clonal" antigen receptor gene rearrangements. Therefore, tests that detect IGH clonal populations can be useful in the study of B- and T-cell malignancies.

## Specimen Requirement

50 ng of high-quality genomic DNA.

## References

1. S Tonegawa. *Nature* 302: 575-581 (1983).
2. JE Miller et al., *Molecular Genetic Pathology* (2nd ed.). Springer Science & Business Media. 2013: 30.2.7.13 and 30.2.7.18.
3. KJ Trainor et al., *Blood* 75: 2220-2222 (1990).
4. P Ghia. *Leukemia* 21: 1-3 (2007).

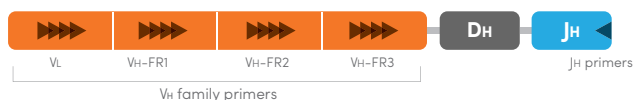

Simple representation of the organization of the immunoglobulin heavy chain (IGH) gene locus on chromosome 14. Depicted are the variable region (V<sub>H</sub>) genes and downstream consensus joining region genes segments (J<sub>H</sub>) that are involved in rearrangements.

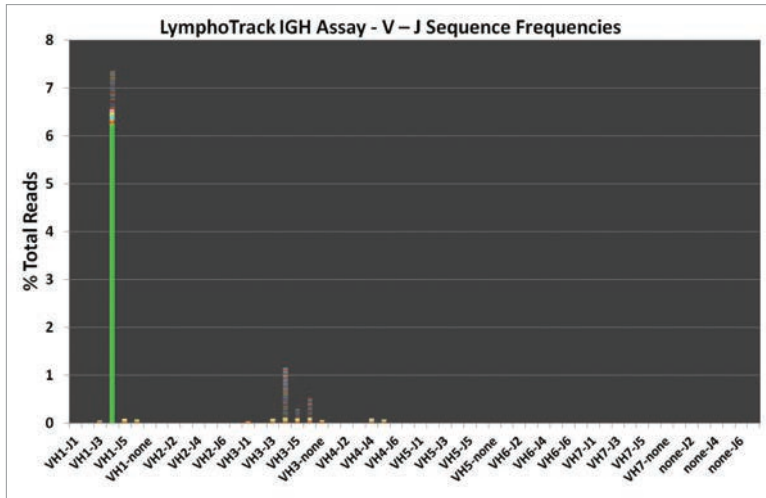

**V-J Sequence Frequencies.** The LymphoTrack Software provides a stacked bar graph depicting the relative frequencies for the 200 most prevalent V<sub>H</sub>-J<sub>H</sub> rearrangements identified in a sample. To learn more about the LymphoTrack software, please refer to the LymphoTrack Bioinformatics Software section.

### Ordering Information

Catalog #	Products	Quantity Components
7-121-0129	LymphoTrack <sup>®</sup> IGH FR1/2/3 Assay Kit A - MiSeq <sup>®</sup>	Indices 1-8 (5 sequencing reactions each)
7-121-0139	LymphoTrack <sup>®</sup> IGH FR1/2/3 Assay Panel - MiSeq <sup>®</sup>	Indices 1-24 (5 sequencing reactions each)
7-121-0009	LymphoTrack <sup>®</sup> IGH FR1 Assay Kit A - MiSeq <sup>®</sup>	Indices 1-8 (5 sequencing reactions each)
7-121-0039	LymphoTrack <sup>®</sup> IGH FR1 Assay Panel - MiSeq <sup>®</sup>	Indices 1-24 (5 sequencing reactions each)
7-121-0149	LymphoTrack <sup>®</sup> IGH FR1 Assay Panel B - MiSeq <sup>®</sup> <b>NEW!</b>	Indices 25-48 (5 sequencing reaction each)
7-121-0089	LymphoTrack <sup>®</sup> IGH FR2 Assay Kit A - MiSeq <sup>®</sup>	Indices 1-8 (5 sequencing reactions each)
7-121-0099	LymphoTrack <sup>®</sup> IGH FR2 Assay Panel - MiSeq <sup>®</sup>	Indices 1-24 (5 sequencing reactions each)
7-121-0109	LymphoTrack <sup>®</sup> IGH FR3 Assay Kit A - MiSeq <sup>®</sup>	Indices 1-8 (5 sequencing reactions each)
7-121-0119	LymphoTrack <sup>®</sup> IGH FR3 Assay Panel - MiSeq <sup>®</sup>	Indices 1-24 (5 sequencing reactions each)
7-500-0009	LymphoTrack <sup>®</sup> Software - MiSeq <sup>®</sup>	1 CD complimentary with purchase
7-121-0057	LymphoTrack <sup>®</sup> IGH FR1/2/3 Assay - S5/PGM™	12 + 12 + 12 indices - 5 sequencing reactions each
7-121-0007	LymphoTrack <sup>®</sup> IGH FR1 Assay - S5/PGM™	12 indices - 5 sequencing reactions each
7-121-0037	LymphoTrack <sup>®</sup> IGH FR2 Assay - S5/PGM™	12 indices - 5 sequencing reactions each
7-121-0047	LymphoTrack <sup>®</sup> IGH FR3 Assay - S5/PGM™	12 indices - 5 sequencing reactions each
7-500-0007	LymphoTrack <sup>®</sup> Software - S5/PGM™	1 CD complimentary with purchase
7-500-0008	LymphoTrack <sup>®</sup> MRD Software	1 CD complimentary with purchase

# LymphoTrack IGH FR1/FR2/FR3 Assays continued

Reagents - MiSeq® Detection							
The LymphoTrack IGH FR1/2/3 Assays contain components from respective individual FR Kit A's or Panels.							
LymphoTrack IGH FR1 Components		LymphoTrack IGH FR2 Components		LymphoTrack IGH FR3 Components			
Master Mix Name	Index #	Master Mix Name	Index #	Master Mix Name	Index #		
IGH FR1 MiSeq 01	A001	IGH FR2 MiSeq 01	A001	IGH FR3 MiSeq 01	A001		
IGH FR1 MiSeq 02	A002	IGH FR2 MiSeq 02	A002	IGH FR3 MiSeq 02	A002		
IGH FR1 MiSeq 03	A003	IGH FR2 MiSeq 03	A003	IGH FR3 MiSeq 03	A003		
IGH FR1 MiSeq 04	A004	IGH FR2 MiSeq 04	A004	IGH FR3 MiSeq 04	A004		
IGH FR1 MiSeq 05	A005	IGH FR2 MiSeq 05	A005	IGH FR3 MiSeq 05	A005		
IGH FR1 MiSeq 06	A006	IGH FR2 MiSeq 06	A006	IGH FR3 MiSeq 06	A006		
IGH FR1 MiSeq 07	A007	IGH FR2 MiSeq 07	A007	IGH FR3 MiSeq 07	A007		
IGH FR1 MiSeq 08	A008	IGH FR2 MiSeq 08	A008	IGH FR3 MiSeq 08	A008		
IGH FR1 MiSeq 09	A009	IGH FR2 MiSeq 09	A009	IGH FR3 MiSeq 09	A009		
IGH FR1 MiSeq 10	A010	IGH FR2 MiSeq 10	A010	IGH FR3 MiSeq 10	A010		
IGH FR1 MiSeq 11	A011	IGH FR2 MiSeq 11	A011	IGH FR3 MiSeq 11	A011		
IGH FR1 MiSeq 12	A012	IGH FR2 MiSeq 12	A012	IGH FR3 MiSeq 12	A012		
IGH FR1 MiSeq 13	A013	IGH FR2 MiSeq 13	A013	IGH FR3 MiSeq 13	A013		
IGH FR1 MiSeq 14	A014	IGH FR2 MiSeq 14	A014	IGH FR3 MiSeq 14	A014		
IGH FR1 MiSeq 15	A015	IGH FR2 MiSeq 15	A015	IGH FR3 MiSeq 15	A015		
IGH FR1 MiSeq 16	A016	IGH FR2 MiSeq 16	A016	IGH FR3 MiSeq 16	A016		
IGH FR1 MiSeq 18	A018	IGH FR2 MiSeq 18	A018	IGH FR3 MiSeq 18	A018		
IGH FR1 MiSeq 19	A019	IGH FR2 MiSeq 19	A019	IGH FR3 MiSeq 19	A019		
IGH FR1 MiSeq 20	A020	IGH FR2 MiSeq 20	A020	IGH FR3 MiSeq 20	A020		
IGH FR1 MiSeq 21	A021	IGH FR2 MiSeq 21	A021	IGH FR3 MiSeq 21	A021		
IGH FR1 MiSeq 22	A022	IGH FR2 MiSeq 22	A022	IGH FR3 MiSeq 22	A022		
IGH FR1 MiSeq 23	A023	IGH FR2 MiSeq 23	A023	IGH FR3 MiSeq 23	A023		
IGH FR1 MiSeq 25	A025	IGH FR2 MiSeq 25	A025	IGH FR3 MiSeq 25	A025		
IGH FR1 MiSeq 27	A027	IGH FR2 MiSeq 27	A027	IGH FR3 MiSeq 27	A027		
IGH FR1 MiSeq 17	A017						
IGH FR1 MiSeq 24	A024						
IGH FR1 MiSeq 26	A026						
IGH FR1 MiSeq 28	A028						
IGH FR1 MiSeq 29	A029						
IGH FR1 MiSeq 30	A030						
IGH FR1 MiSeq 31	A031						
IGH FR1 MiSeq 32	A032						
IGH FR1 MiSeq 33	A033						
IGH FR1 MiSeq 34	A034						
IGH FR1 MiSeq 35	A035						
IGH FR1 MiSeq 36	A036						
IGH FR1 MiSeq 37	A037						
IGH FR1 MiSeq 38	A038						
IGH FR1 MiSeq 39	A039						
IGH FR1 MiSeq 40	A040						



## Reagents - MiSeq® Detection cont.

The LymphoTrack IGH FR1/2/3 Assays contain components from respective individual FR Kit A's or Panels.

LymphoTrack IGH FR1 Components		LymphoTrack IGH FR2 Components		LymphoTrack IGH FR3 Components	
Master Mix Name	Index #	Master Mix Name	Index #	Master Mix Name	Index #
IGH FR1 MiSeq 41	A041				
IGH FR1 MiSeq 42	A042				
IGH FR1 MiSeq 43	A043				
IGH FR1 MiSeq 44	A044				
IGH FR1 MiSeq 45	A045				
IGH FR1 MiSeq 46	A046				
IGH FR1 MiSeq 47	A047				
IGH FR1 MiSeq 48	A048				
IGH FR1 MiSeq 49	A049				
Controls in Individual FR (1, 2, or 3) Kit A's		Controls in Individual FR (1,2, or 3) Panels		Controls in Combo FR 1/2/3 Kit A	
IGH POS (+) Qty. 1		IGH POS (+) Qty. 3		IGH POS (+) Qty. 2	
NGS NEG (-) Qty. 1		NGS NEG (-) Qty. 3		NGS NEG (-) Qty. 2	
				Controls in Combo FR 1/2/3 Panel	
				IGH POS (+) Qty. 6	
				NGS NEG (-) Qty. 6	

Kit A's contain indices IGH FRX A001 to A008. Panels contain all master mixes listed on pg. 40

## Reagents - Ion S5™/PGM™ Detection

The LymphoTrack IGH FR1/2/3 Assays contain components from respective individual FR Assays.

LymphoTrack IGH FR1 Components		LymphoTrack IGH FR2 Components		LymphoTrack IGH FR3 Components	
Master Mix Name	Index #	Master Mix Name	Index #	Master Mix Name	Index #
IGH FR1 S5/PGM 01	IonXpress_001	IGH FR2 S5/PGM 01	IonXpress_001	IGH FR3 S5/PGM 01	IonXpress_001
IGH FR1 S5/PGM 02	IonXpress_002	IGH FR2 S5/PGM 02	IonXpress_002	IGH FR3 S5/PGM 02	IonXpress_002
IGH FR1 S5/PGM 03	IonXpress_003	IGH FR2 S5/PGM 03	IonXpress_003	IGH FR3 S5/PGM 03	IonXpress_003
IGH FR1 S5/PGM 04	IonXpress_004	IGH FR2 S5/PGM 04	IonXpress_004	IGH FR3 S5/PGM 04	IonXpress_004
IGH FR1 S5/PGM 07	IonXpress_007	IGH FR2 S5/PGM 07	IonXpress_007	IGH FR3 S5/PGM 07	IonXpress_007
IGH FR1 S5/PGM 08	IonXpress_008	IGH FR2 S5/PGM 08	IonXpress_008	IGH FR3 S5/PGM 08	IonXpress_008
IGH FR1 S5/PGM 09	IonXpress_009	IGH FR2 S5/PGM 09	IonXpress_009	IGH FR3 S5/PGM 09	IonXpress_009
IGH FR1 S5/PGM 10	IonXpress_010	IGH FR2 S5/PGM 10	IonXpress_010	IGH FR3 S5/PGM 10	IonXpress_010
IGH FR1 S5/PGM 11	IonXpress_011	IGH FR2 S5/PGM 11	IonXpress_011	IGH FR3 S5/PGM 11	IonXpress_011
IGH FR1 S5/PGM 12	IonXpress_012	IGH FR2 S5/PGM 12	IonXpress_012	IGH FR3 S5/PGM 12	IonXpress_012
IGH FR1 S5/PGM 13	IonXpress_013	IGH FR2 S5/PGM 13	IonXpress_013	IGH FR3 S5/PGM 13	IonXpress_013
IGH FR1 S5/PGM 14	IonXpress_014	IGH FR2 S5/PGM 14	IonXpress_014	IGH FR3 S5/PGM 14	IonXpress_014
Controls in Individual FR (1,2, or 3) Kits			Controls in FR 1/2/3 Kit		
IGH POS (+) Qty. 2			IGH POS (+) Qty. 4		
NGS NEG (-) Qty. 2			NGS NEG (-) Qty. 4		

# LymphoTrack *IGK* Assay

## Assay Uses

This research use only (RUO) assay for next-generation sequencing (NGS), identifies clonal *IGK* V $\kappa$ -J $\kappa$ , V $\kappa$ -K $\text{de}$ , and intron-K $\text{de}$  (INTR-K $\text{de}$ ) rearrangements, the corresponding DNA sequences, and provides the distribution frequency of V $\kappa$ -J $\kappa$ , V $\kappa$ -K $\text{de}$ , and INTR-K $\text{de}$  segment utilization using the Illumina<sup>®</sup> MiSeq<sup>®</sup> or Thermo Fisher Scientific<sup>®</sup> Ion PGM<sup>™</sup> and Ion S5<sup>™</sup> platforms.

## Summary and Explanation of the Test

The LymphoTrack *IGK* Assay represents a significant improvement over clonality assays that utilize fragment analysis by providing three important and complementary uses:

1. Detection of clonal populations.
2. Identification of sequence information and gene segment utilization.
3. Ability to track sequences in subsequent samples with the use of the LymphoTrack MRD Software.

Unlike conventional fragment analysis assays, this NGS method utilizes a single multiplex master mix to target conserved regions of *IGK* that are described in lymphoid malignancies. Primers are designed with Illumina<sup>®</sup> adapters and indices (8-24) or Thermo Fisher Scientific adapters and indices (12), thereby allowing for a one-step PCR reaction to generate sequence-ready amplicons. To reduce per sample testing costs, amplicons from different samples (amplified with different indexed master mixes) or LymphoTrack kits can be sequenced together on a single Illumina<sup>®</sup> MiSeq<sup>®</sup> flow cell, Ion S5<sup>™</sup> or PGM<sup>™</sup> chips.

The LymphoTrack bioinformatics software enables simplified analysis and visualization of data and the LymphoTrack MRD Software allows identified sequences to be tracked in subsequent samples. Please see the LymphoTrack MRD software section to learn how the LymphoTrack Assays can be applied to MRD studies, or email [marketing@invivoscribe.com](mailto:marketing@invivoscribe.com). Positive (clonal) and negative (polyclonal) DNA controls are included in the kits.

## Background

The human immunoglobulin kappa (*IGK*) gene locus on chromosome 2 (2p11.2) includes 76 V (variable) region genes spanning 7 subgroups and 5 J (joining) region gene segments upstream of the C $\kappa$  region. The K $\text{de}$ , approximately 24 kb downstream of the J $\kappa$ -C $\kappa$  region, can also rearrange with V $\kappa$  gene segments and the isolated recombination signal sequence in the J $\kappa$ -C $\kappa$  intronic region.

During development of lymphoid cells, antigen receptor genes undergo somatic gene rearrangements. Specifically during B-cell development, genes encoding *IGK* molecules are assembled from multiple polymorphic gene segments that undergo rearrangements generating V-J combinations unique in both length and sequence. Since leukemias and lymphomas originate from the malignant transformation of individual lymphoid cells, all leukemias and lymphomas generally share one or more cell-specific or "clonal" antigen receptor gene rearrangements. Therefore, tests that detect *IGK* clonal populations can be useful in the study of B-cell malignancies and complement *IGH* testing, as the *IGK* receptor is less susceptible to somatic mutations.

## Specimen Requirement

50 ng of high-quality genomic DNA.

## References

1. S Tonegawa et al., *Nature* 302: 575-581 (1983).
2. JE Miller et al., *Molecular Genetic Pathology* (2nd ed.). Springer Science & Business Media. 2013: 30.2.7.13 and 30.2.7.18.
3. KJ Trainor et al., *Blood* 75: 2220-2222 (1990).

## Simplified Representation of the *IGK* Gene



Depicted are the variable region (V $\kappa$ ) genes or variable intragenic J $\kappa$ -C $\kappa$  intron (J $\kappa$ -C $\kappa$  INTR) and downstream consensus joining region genes (J $\kappa$ ) or kappa deleting element (K $\text{de}$ ) that are involved in *IGK* gene rearrangements.

## Reagents - MiSeq® Detection

Kit A Components		Panel Components (includes all master mixes from Kit A plus the items below)			
Master Mix Name	Index #	Master Mix Name	Index #	Master Mix Name	Index #
IGK MiSeq 01	A001	IGK MiSeq 09	A009	IGK MiSeq 18	A018
IGK MiSeq 02	A002	IGK MiSeq 10	A010	IGK MiSeq 19	A019
IGK MiSeq 03	A003	IGK MiSeq 11	A011	IGK MiSeq 20	A020
IGK MiSeq 04	A004	IGK MiSeq 12	A012	IGK MiSeq 21	A021
IGK MiSeq 05	A005	IGK MiSeq 13	A013	IGK MiSeq 22	A022
IGK MiSeq 06	A006	IGK MiSeq 14	A014	IGK MiSeq 23	A023
IGK MiSeq 07	A007	IGK MiSeq 15	A015	IGK MiSeq 25	A025
IGK MiSeq 08	A008	IGK MiSeq 16	A016	IGK MiSeq 27	A027
Controls		Controls			
IGK POS (+) Qty. 1	NGS NEG (-) Qty. 1	IGK POS (+) Qty. 3	NGS NEG (-) Qty. 3		

## Reagents - Ion S5/PGM™ Detection

Assay Components			
Master Mix Name	Index #	Master Mix Name	Index #
IGK S5/PGM 01	IonXpress_001	IGK S5/PGM 11	IonXpress_011
IGK S5/PGM 02	IonXpress_002	IGK S5/PGM 12	IonXpress_012
IGK S5/PGM 04	IonXpress_004	IGK S5/PGM 13	IonXpress_013
IGK S5/PGM 08	IonXpress_008	IGK S5/PGM 14	IonXpress_014
IGK S5/PGM 09	IonXpress_009	IGK S5/PGM 16	IonXpress_016
IGK S5/PGM 010	IonXpress_010	IGK S5/PGM 17	IonXpress_017
Controls			
IGK POS (+) Qty. 2	NGS NEG (-) Qty. 2		

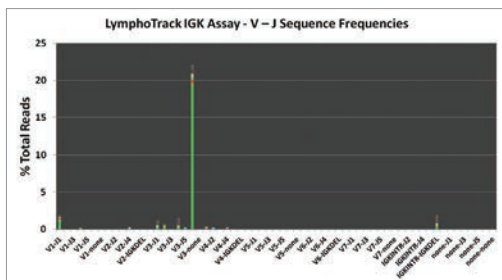

**V-J Sequence Frequencies.** The LymphoTrack bioinformatics software provides a stacked bar graph depicting the relative frequencies for the 200 most prevalent rearrangements sequenced and identified in the sample. To learn more about the LymphoTrack software, please refer to the LymphoTrack Bioinformatics Software section.

## Ordering Information

Catalog #	Products	Quantity Components
7-122-0009	LymphoTrack® IGK Assay Kit A - MiSeq®	8 indices - 5 sequencing reactions each
7-122-0019	LymphoTrack® IGK Assay Panel - MiSeq®	24 indices - 5 sequencing reactions each
7-500-0009	LymphoTrack® Software - MiSeq®	1 CD complimentary with purchase
7-122-0007	LymphoTrack® IGK Assay - S5/PGM™	12 indices - 5 sequencing reactions each
7-500-0007	LymphoTrack® Software - S5/PGM™	1 CD complimentary with purchase
7-500-0008	LymphoTrack® MRD Software*	1 CD complimentary with purchase

\*MRD Software can be used to track sequences generated by either LymphoTrack Assays - MiSeq® or Ion S5/PGM™.

# LymphoTrack TRG Assay

## Assay Uses

This research use only (RUO) assay for next-generation sequencing (NGS) identifies clonal *TRG* V-J rearrangements and the associated V-J region DNA sequences. It also provides the frequency distribution of V-J segment utilization using the Illumina<sup>®</sup> MiSeq<sup>®</sup> or Thermo Fisher Scientific<sup>®</sup> Ion S5<sup>™</sup> and PGM<sup>™</sup> instruments.

## Summary and Explanation of the Test

The LymphoTrack TRG Assay represents a significant improvement over existing clonality assays that utilize fragment analysis by providing three important and complementary uses:

1. Detection of clonal populations.
2. Identification of sequence information and gene segment utilization.
3. Ability to track sequences in subsequent samples with the use of the Invivoscribe MRD Software.

The single multiplex master mix targets all conserved regions within the variable (V) and the joining (J) genes described in lymphoid malignancies. The average PCR amplicon size of the *TRG* gene rearrangements generated using this assay was designed to be compatible with fragmented DNA isolated from challenging samples such as FFPE sections.

Primers are designed with Illumina<sup>®</sup> adapters and indices (8-24) or Thermo Fisher Scientific adapters and indices (12), thereby allowing for a one-step PCR reaction to generate sequence-ready amplicons. In addition, amplicons from different samples (amplified with different indexed master mixes) or LymphoTrack kits can be sequenced together on a single Illumina<sup>®</sup> MiSeq<sup>®</sup> flow cell Ion S5<sup>™</sup> or PGM<sup>™</sup> chip to reduce per sample testing costs.

The LymphoTrack bioinformatics software enables simplified analysis and visualization of data generated from this assay and the LymphoTrack MRD Software allows sequences to be tracked in subsequent samples. Please see the LymphoTrack MRD software section to learn how the LymphoTrack Assays can be applied to MRD studies, or email [marketing@invivoscribe.com](mailto:marketing@invivoscribe.com). Positive (clonal) and negative (polyclonal) DNA controls are included in the kits.

## Background

The human T-cell receptor gamma (*TRG*) gene locus on chromosome 7 (7q14) includes 14 variable region (Group I, II, III, and IV), 5 joining region (J) gene segments, and 2 constant (C) genes spread over 200 kilobases.

During development of lymphoid cells, the antigen receptor genes (including gene segments within the *TRG* locus), undergo somatic gene rearrangement. These developmentally regulated gene rearrangements generate V-J combinations that are unique for each cell. Since leukemias and lymphomas originate from the malignant transformation of individual lymphoid cells, all leukemias and lymphomas generally share one or more cell-specific or “clonal” antigen receptor gene rearrangements. Therefore, tests that detect *TRG* clonal populations can be useful in the study of T-cell and certain B-cell malignancies. Since the *TRG* locus rearranges before the *TRB* locus, and all unsuccessful or unproductive rearrangements are retained in the cells, examination of the *TRG* locus can identify both clonal  $\Delta\gamma$  as well as clonal  $\alpha/\beta$  T-cells. Clonal  $\alpha/\beta$  T-cells would be expected to have biallelic *TRG* gene rearrangements.

## Specimen Requirement

50 ng of high-quality genomic DNA.

## References

1. S Tonegawa et al., *Nature* 302: 575-581 (1983).
2. JE Miller et al., *Molecular Genetic Pathology* (2nd ed.). Springer Science & Business Media. 2013: 30.2.7.13 and 30.2.7.18.
3. KJ Trainor et al., *Blood* 75: 2220-2222 (1990).

## Simplified Representation of the TRG Gene



Simple representation of the organization of the T-cell receptor gamma gene on chromosome 7. Depicted are the variable region genes (Vγ2–Vγ11) and downstream joining region genes (Jγ1/2–JγP1/2) that are involved in rearrangements in T-cell lymphomas.

## Reagents - MiSeq<sup>®</sup> Detection

Kit A Components		Panel Components (includes all master mixes from Kit A plus the items below)			
Master Mix Name	Index #	Master Mix Name	Index #	Master Mix Name	Index #
TRG MiSeq 01	A001	TRG MiSeq 09	A009	TRG MiSeq 18	A018
TRG MiSeq 02	A002	TRG MiSeq 10	A010	TRG MiSeq 19	A019
TRG MiSeq 03	A003	TRG MiSeq 11	A011	TRG MiSeq 20	A020
TRG MiSeq 04	A004	TRG MiSeq 12	A012	TRG MiSeq 21	A021
TRG MiSeq 05	A005	TRG MiSeq 13	A013	TRG MiSeq 22	A022
TRG MiSeq 06	A006	TRG MiSeq 14	A014	TRG MiSeq 23	A023
TRG MiSeq 07	A007	TRG MiSeq 15	A015	TRG MiSeq 25	A025
TRG MiSeq 08	A008	TRG MiSeq 16	A016	TRG MiSeq 27	A027
Controls		Controls			
TRG POS (+) Qty. 1	NGS NEG (-) Qty. 1	TRG POS (+) Qty. 3		NGS NEG (-) Qty. 3	

## Reagents - Ion S5/PGM<sup>™</sup> Detection

Assay Components					
Master Mix Name	Index #	Master Mix Name	Index #	Master Mix Name	Index #
TRG S5/PGM 01	IonXpress_001	TRG S5/PGM 07	IonXpress_007	TRG S5/PGM 11	IonXpress_011
TRG S5/PGM 02	IonXpress_002	TRG S5/PGM 08	IonXpress_008	TRG S5/PGM 12	IonXpress_012
TRG S5/PGM 03	IonXpress_003	TRG S5/PGM 09	IonXpress_009	TRG S5/PGM 13	IonXpress_013
TRG S5/PGM 04	IonXpress_004	TRG S5/PGM 10	IonXpress_010	TRG S5/PGM 14	IonXpress_014
Controls					
TRG POS (+) Qty. 2			NGS NEG (-) Qty. 2		

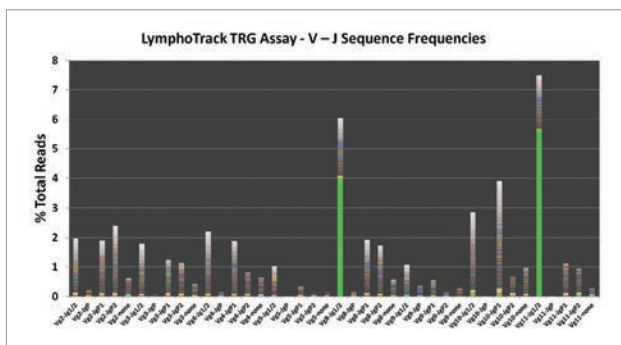

**V - J Sequence Frequencies.** The LymphoTrack bioinformatics software provides a stacked bar graph depicting the relative frequencies for the V-J rearrangements identified and sequenced in a sample. To learn more about the LymphoTrack software, please refer to the LymphoTrack Bioinformatics Software section.

## Ordering Information

Catalog #	Products	Quantity Components
7-227-0019	LymphoTrack <sup>®</sup> TRG Assay Kit A - MiSeq <sup>®</sup>	8 indices - 5 sequencing reactions each
7-227-0009	LymphoTrack <sup>®</sup> TRG Assay Panel - MiSeq <sup>®</sup>	24 indices - 5 sequencing reactions each
7-500-0009	LymphoTrack <sup>®</sup> Software - MiSeq <sup>®</sup>	1 CD complimentary with purchase
7-227-0007	LymphoTrack <sup>®</sup> TRG Assay - S5/PGM <sup>™</sup>	12 indices - 5 sequencing reactions each
7-500-0007	LymphoTrack <sup>®</sup> Software - S5/PGM <sup>™</sup>	1 CD complimentary with purchase
7-500-0008	LymphoTrack <sup>®</sup> MRD Software*	1 CD complimentary with purchase

\*MRD Software can be used to track sequences generated by either LymphoTrack Assays - MiSeq<sup>®</sup> or Ion S5/PGM<sup>™</sup>.

# LymphoTrack *TRB* Assay

## Assay Uses

This research use only (RUO) assay for next-generation sequencing (NGS) identifies clonal *TRB* V $\beta$ -(D $\beta$ -)J $\beta$  rearrangements, the associated V $\beta$ -(D $\beta$ -)J $\beta$  region DNA sequences, it provides the frequency distribution of V $\beta$ , D $\beta$ , and J $\beta$  region segment utilization using the Illumina<sup>®</sup> MiSeq<sup>®</sup> platform.

## Summary and Explanation of the Test

In contrast to the conventional fragment analysis assays for clonality that utilize three master mixes, this NGS-based assay contains a single multiplex master mix to target conserved V, D, and J regions of the *TRB* gene locus described in lymphoid malignancies. This reduces DNA sample requirements and simplifies the testing workflow. The LymphoTrack *TRB* master mix primers are also designed with Illumina<sup>®</sup> adapters and 8 indices (Kit A) or 24 indices (Panel). This allows amplicons generated from different indexed *TRB* master mixes to be pooled into a single sequencing library.

The associated LymphoTrack Software is capable of sorting complex NGS data by gene target. This offers a second layer of multiplexing to reduce per sample testing costs by allowing amplicons from any LymphoTrack Assay (e.g. *IGH*, *IGK*, *TRB*, *TRG*) to be sequenced on the same flow cell. In addition, the LymphoTrack Software provides easy visualization of data and the LymphoTrack Minimal Residual Disease Data Analysis Tool allows identified sequences to be tracked and monitored in subsequent samples. Positive clonal and negative polyclonal DNA controls are included in kits. Please see the LymphoTrack MRD software section to learn how the LymphoTrack Assays can be applied to MRD studies, or email [marketing@invivoscribe.com](mailto:marketing@invivoscribe.com).

## Background

The LymphoTrack *TRB* Assay represent a significant improvement over clonality assessment by fragment analysis by providing two important and complementary uses:

1. Detection of initial clonal populations.
2. Identification of sequence information required to track clonal rearrangements in subsequent samples.

Analysis of the rearranged *TRB* locus increases the probability of identifying T-cell receptor gene rearrangements, as compared to testing for *TRG* gene rearrangements only. As a result, combining the analysis of *TRB* and *TRG* loci increases the sensitivity of clonality detection.

The human T-cell receptor beta (*TRB*) gene locus on chromosome 7 (7q34) includes 65 V $\beta$  (variable) gene segments, followed by two separate clusters of genes each containing a D $\beta$  (diversity) gene, several J $\beta$  (joining) genes, and a C $\beta$  (constant) region spread over 685 kilobases. The two C $\beta$  genes, *TRBC1* and *TRBC2*, encode highly homologous products with no functional difference.

During lymphoid cell development, antigen receptor genes undergo somatic gene rearrangements. Specifically, during T-cell development, genes encoding *TRB* molecules are assembled from multiple polymorphic gene segments that generate V $\beta$ -D $\beta$ -J $\beta$  combinations unique in both length and sequence.

Since leukemias and lymphomas originate from the malignant transformation of individual lymphoid cells, all leukemias and lymphomas generally share one or more cell-specific or "clonal" antigen receptor gene rearrangements. Therefore, tests that detect *TRB* clonal rearrangements can be useful in the study of B- and T-cell malignancies.

## Specimen Requirement

50 ng of high-quality genomic DNA.

## References

1. EP Rock et al., *J Exp Med* 179 (1): 323-8 (1994).
2. JE Miller et al., *Molecular Genetic Pathology* (2nd Ed., sections 30.2.7.13 and 30.2.7.18). New York, USA: Springer Science & Business Media (2013).

## Simplified Representation of the *TRB* Gene



Depicted are the variable (V $\beta$ ), diversity (D $\beta$ ), and joining (J $\beta$ ) gene regions involved in *TRB* gene rearrangements, in addition to the downstream consensus (C $\beta$ ) gene regions.

## Reagents - MiSeq<sup>®</sup> Detection

Kit A Components		Panel Components (includes all master mixes from Kit A plus the items below)			
Master Mix Name	Index #	Master Mix Name	Index #	Master Mix Name	Index #
TRB MiSeq 01	A001	TRB MiSeq 09	A009	TRB MiSeq 18	A018
TRB MiSeq 02	A002	TRB MiSeq 10	A010	TRB MiSeq 19	A019
TRB MiSeq 03	A003	TRB MiSeq 11	A011	TRB MiSeq 20	A020
TRB MiSeq 04	A004	TRB MiSeq 12	A012	TRB MiSeq 21	A021
TRB MiSeq 05	A005	TRB MiSeq 13	A013	TRB MiSeq 22	A022
TRB MiSeq 06	A006	TRB MiSeq 14	A014	TRB MiSeq 23	A023
TRB MiSeq 07	A007	TRB MiSeq 15	A015	TRB MiSeq 25	A025
TRB MiSeq 08	A008	TRB MiSeq 16	A016	TRB MiSeq 27	A027
Controls		Controls			
TRB POS (+) Qty. 1	NGS NEG (-) Qty. 1	TRB POS (+) Qty. 3		NGS NEG (-) Qty. 3	

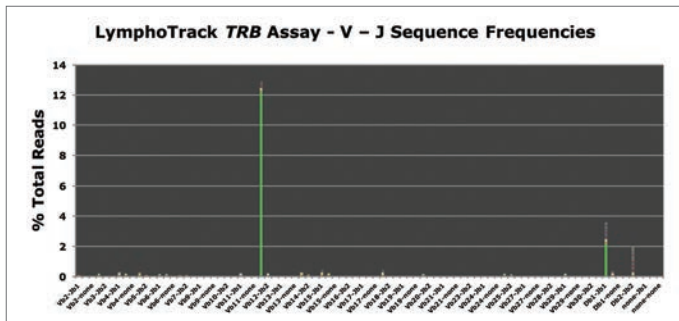

**V-J Sequence Frequencies.** The LymphoTrack bioinformatics software provides PDF reports which include Top 10 Merged Read Summary as well as a stacked bar graph depicting the relative frequencies of the 200 most prevalent rearrangements sequenced and identified in the sample. To learn more about the LymphoTrack software, please refer to the LymphoTrack Bioinformatics Software section.

## Ordering Information

Catalog #	Products	Quantity Components
7-225-0009	LymphoTrack <sup>®</sup> TRB Assay Kit A - MiSeq <sup>®</sup>	8 indices - 5 sequencing reactions each
7-225-0019	LymphoTrack <sup>®</sup> TRB Assay Panel - MiSeq <sup>®</sup>	24 indices - 5 sequencing reactions each
7-500-0009	LymphoTrack <sup>®</sup> Software - MiSeq <sup>®</sup>	1 CD complimentary with purchase
7-500-0008	LymphoTrack <sup>®</sup> MRD Software*	1 CD complimentary with purchase

\*MRD Software can be used to track sequences generated by either LymphoTrack Assays - MiSeq<sup>®</sup> or Ion S5/PGM<sup>™</sup>. MRD applications are for Research Use Only. To obtain a copy, please contact your local distributor or send an e-mail to [customerservice@invivoscribe.com](mailto:customerservice@invivoscribe.com).

# LymphoTrack Bioinformatics Software

## Software Use

The LymphoTrack Bioinformatics Software package is provided with each LymphoTrack Assay to analyze raw FASTQ files for clonality analysis of single or multiple target data sets (*IGHV* Leader (Leader), *IGH* FR1, *IGH* FR2, *IGH* FR3, *IGK*, *TRG*, *TRB*). For data generated with LymphoTrack *IGHV* Leader or *IGH* FR1 Assays the software provides additional information, including the rate of somatic hypermutation (SHM) and whether a clone will be functional based upon the presence of a premature stop codon. The software can also predict whether an open reading frame would be in- or out-of-frame, so no external data analysis is required for sample interpretation.

The provided software is composed of two distinct parts:

1. A bioinformatics Data Analysis Application
2. Microsoft Excel<sup>®</sup> Data Visualization spreadsheets for each gene target and automated Sample-to-PDF Reports for streamlined data analysis.

## Minimum Software Requirements

- Processor: Intel Core 2 Duo or newer CPU recommended.
- Hard Drive: At least 80 GB of free disk space is required; 250 GB recommended.
- RAM: 4 GB required; 8 GB or more recommended.

- Operating System: Windows 7 (64-bit) is required.
- Java 8 for 64-bit operating systems or higher (Java configured for 32-bit operating systems is not compatible with the LymphoTrack Software – MiSeq or LymphoTrack Software – S5/PGM). The most recent version of Java can be downloaded directly from Oracle at <http://www.java.com/>.
- A PDF reader, such as Adobe Acrobat Reader, to visualize data reports generated by the LymphoTrack Reporter.
- Microsoft Office Excel 2007, 2010, or 2013 with Macro support enabled is required for data visualization.
- A CD-ROM drive.
- The LymphoTrack Software – MiSeq has been validated for use with Windows 7 configured for English (United States) language and default display size settings, and Microsoft Excel 2007/2010/2013 for alternate data visualization. Use of other Windows/Excel versions and/or language/display size settings may not be compatible.
- The LymphoTrack Software – S5/PGM has been validated for use with Microsoft Excel 2007/2010/2013/2016 and Windows 7 or Windows 10 configured for English (United States) language and default display size settings, and for alternate data visualization. Use of other Windows/Excel versions and/or language/display size settings may not be compatible.

## Sequence Frequency Graph

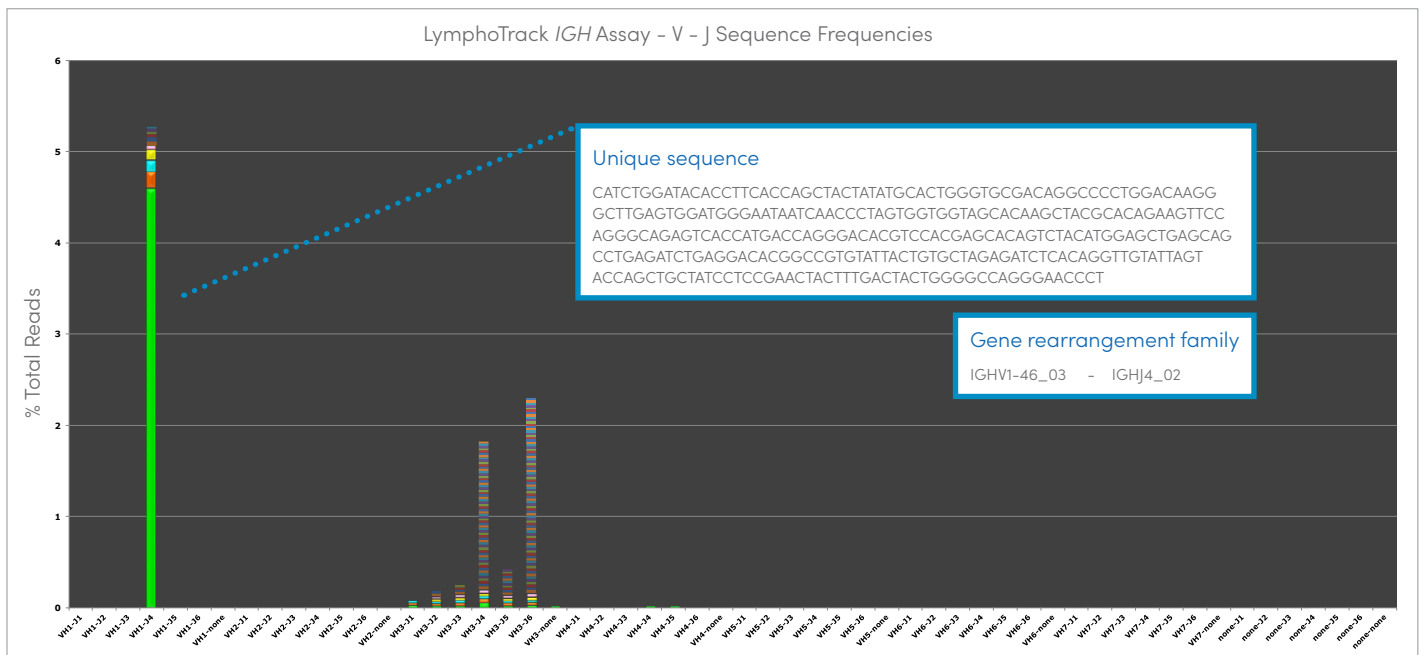

The stacked bar graph depicts the top 200 sequencing reads for a sample. Each individual colored bar represents a unique population of cells. Different colors stacked at the same point on the x-axis represent unique sequences that utilize the same V and J gene families. The amplicons of these products vary in sequence and may also vary in product size.



## Sequencing Summary

Using the merged read summary interpretation is quick and easy.

1 Easy identification of specific types of gene rearrangements such as *IGHV3-21*.

Rank	Sequence	Length	Merge count	V-gene	J-gene	% Total reads	Cumulative %	Mutation rate partial V-gene (%)	In-frame (Y/N)	No stop codon (Y/N)	V-coverage
1	TTCTCGTGGTG	455	29603	IGHV4-59_08	IGHJ4_02	9.93	9.93	11.26	Y	Y	98.63
2	CTCGCCCTCCT	463	205	IGHV5-51_01	IGHJ4_02	0.07	9.99	0.00	Y	Y	99.66
3	GGTTTTCTTG	484	201	IGHV3-7_01	IGHJ4_02	0.07	10.06	7.77	Y	Y	100.00
4	CTCGCCCTCCT	463	185	IGHV5-51_01	IGHJ5_02	0.06	10.12	6.08	Y	Y	99.32
5	CTCGCCCTCCT	469	170	IGHV5-51_01	IGHJ4_02	0.06	10.18	0.00	Y	Y	99.32
6	CTCGCCCTCCT	466	160	IGHV5-51_01	IGHJ4_02	0.05	10.23	0.00	Y	Y	99.66
7	CTGCTGCTGAC	460	159	IGHV2-5_10	IGHJ5_02	0.05	10.29	8.08	Y	Y	97.64
8	GGTTTTCTTG	493	156	IGHV3-48_02	IGHJ6_02	0.05	10.34	3.72	Y	Y	98.99
9	CTCGCCCTCCT	334	153	IGHV5-51_02	IGHJ2_01	0.05	10.39	3.72	Y	N	27.70
10	CTCGCCCTCCT	334	152	IGHV5-51_02	IGHJ2_01	0.05	10.44	3.38	Y	N	26.01

2 Identification of clonal sequences for follow up tracking with LymphoTrack MRD Software.

3 SHM rate and indicators to determine whether a clone is productive. Only provided for *IGHV* Leader and *IGH* FR1.

The read summary provides sequences from a sample ranked from most abundant to least prevalent. The total read count for individual sequences is provided and no independent analysis is required to determine V and J gene families and predictions for SHM when analyzing data from LymphoTrack *IGHV* Leader or *IGH* FR1 Assays. Additionally, the software provides raw and merged data in which reads that differ by 1-2 bp are automatically merged to account for possible sequencing errors and to improve the accuracy and ease of sample interpretation. combined.

### Ordering Information

Catalog #	Products	Quantity Components
7-500-0009	LymphoTrack <sup>®</sup> Software- MiSeq <sup>®</sup>	1 CD complimentary with kit purchase
7-500-0007	LymphoTrack <sup>®</sup> Software - S5/PGM <sup>™</sup>	1 CD complimentary with kit purchase



## Minimal Residual Disease (MRD) Solution

### Key Benefits

- » Complete solution for MRD clonality testing includes controls and software
- » Ensures test sensitivity to enable confidence in reporting
- » Facilitates standardization of clonotype tracking
- » LymphoTrack MRD Software for automated analyses with PDF Reports
- » Longitudinal assessment of mutation status of B- and T-cell clonality including gene rearrangements and somatic hypermutation (SHM)
- » LymphoTrack Assays formatted for both Illumina® and Thermo Fisher NGS Platforms available

52/ LymphoTrack Minimal Residual Disease (MRD) Software

55/ LymphoQuant B-cell & T-cell Internal Control

54/ LymphoTrack B-cell & T-cell Low Positive Controls

#### WARRANTY AND LIABILITY

Invivoscribe® (Invivoscribe®) is committed to providing the highest quality products. Invivoscribe® warrants that the products meet or exceed the performance standards described in the Instructions For Use, as to products with such an insert. If a product is covered by product specifications and does not perform as specified, our policy is to replace the product or credit the full purchase price. No other warranties of any kind, expressed or implied, are provided by Invivoscribe®. Invivoscribe® liability shall not exceed the purchase price of the product. Invivoscribe® shall have no liability for direct, indirect, consequential or incidental damages arising from the use, results of use, or inability to use its products; product efficacy under purchaser controlled conditions in purchaser's laboratory must be established and continually monitored through purchaser defined and controlled processes including but not limited to testing of positive, negative, and blank controls every time a sample is tested. Ordering, acceptance and use of product constitutes purchaser acceptance of sole responsibility for assuring product efficacy and purchaser agreement to the limitation of liability set forth in this paragraph.

NOTICE: Many of the products listed in the section that follows may be covered by one or more of the following patents and patent applications owned by or exclusively licensed to Invivoscribe, Inc.: United States Patent Number 7,785,783, United States Patent Number 8,859,748, United States Patent 10,280,462, European Patent Number EP 1549764B1 (validated in 16 countries, and augmented by related European Patents Numbered EP2418287A3 and EP 2460889A3), Japanese Patent Number JP04708029B2, Japanese Patent Application Number 2006-529437, Brazil Patent Application Number PI0410283.5, Canadian Patent Number CA2525122, Indian Patent Number IN243620, Mexican Patent Number MX286493, Chinese Patent Number CN1806051, and Korean Patent Number 101215194.

These products use nucleic acid amplification methods such as Polymerase Chain Reaction (PCR). Any necessary license to practice amplification methods or to use reagents, amplification enzymes or equipment covered by third party patents is the responsibility of the user and no such license is granted by Invivoscribe, Inc., expressly or by implication.

Research Use Only (RUO) assays are not for sale in Europe and other global markets where equivalent CE-IVD assays are available and registered with the appropriate regulatory agencies.



## MRD testing by Next-Generation Sequencing (NGS) is a proven tool in the development of management strategies for hematologic malignancies.

A number of investigators have described NGS-based approaches that have demonstrated success in detecting and monitoring MRD in Chronic Lymphocytic Leukemia (CLL), Acute Lymphoblastic Leukemia (ALL) and other lymphoid malignancies.<sup>1,2</sup> LymphoTrack Assays are NGS-based deep sequencing assays that detect virtually all clonal rearrangements within targeted T-cell receptor (TCR) or immunoglobulin (Ig) antigen receptor loci. Once a specific rearrangement (the clonotype) has been identified, LymphoTrack assays can be used to track these clonotype populations to a sensitivity as low as  $10^{-6}$ . Complementing the LymphoTrack Assays, the LymphoTrack MRD solution is a bundled product set for improved Minimal Residual Disease (MRD) assessment and tracking of rearrangement (clonotype) sequences.

LymphoTrack MRD B-cell and T-cell bundles offer a complete MRD solution for clonality tracking. B- or T-cell bundles may be purchased that include the LymphoTrack Assay, LymphoTrack MRD Bioinformatics Software, a LymphoTrack Low Positive Control and a LymphoQuant Internal Control. Each bundle facilitates the standardization of MRD testing by providing controls suitable for longitudinal MRD tracking with test sensitivity assurance. LymphoTrack MRD Software further simplifies clonal tracking due to rich sequence specific data analyses. This software enables longitudinal monitoring of clonal populations by providing multiple functionalities to the user including project planning features and automated bioinformatics applications.

When monitoring MRD, a highly sensitive detection method such as NGS-based LymphoTrack may aid in the early detection of lymphoproliferative disease relapse. However, MRD test results are dependent on DNA amounts interrogated, as well as the confidence level of the test. Controls tracking MRD test sensitivity are thus necessary when reporting MRD test results. Designed for MRD testing, the LymphoTrack Low Positive Control confirms the sensitivity of respective LymphoTrack MRD runs match or exceed a  $10^{-4}$  (or 1 in 10,000) level. Detection of the LymphoTrack Low Positive Control thus lessens false negative reporting concerns at  $10^{-4}$ , and is further necessary to report MRD negative results with confidence at  $10^{-4}$ .

Consistent use of a spike-in internal control promotes objective monitoring of clonality over time enabling test standardization. To serve this need, Invivoscribe offers a LymphoQuant B-cell and T-cell Internal Control. Addition of a spike-in LymphoQuant B-cell or T-cell Internal Control to samples allows for the estimation of clonotype cell equivalents to facilitate longitudinal clonotype tracking over time.

# LymphoTrack Minimal Residual Disease (MRD) Software

## Software Use

The LymphoTrack MRD Bioinformatics Software package is provided with each LymphoTrack Assay upon request to aid in the evaluation of treatment response in many lymphoid malignancies such as Acute Lymphoblastic Leukemia and Multiple Myeloma to minimize the risk of patients relapsing. The exceptional sensitivity and precision of NGS-based MRD tracking can accelerate clinical trials and drug development. This MRD software is intended to detect the presence of clonotype sequences within the output files generated using the Invivoscribe LymphoTrack Assays and accompanying LymphoTrack bioinformatics software; it is not intended to define the significance of these findings. Once a specific rearrangement sequence (the clonotype) has been identified in a primary sample, the MRD software enables streamlined tracking of clonal populations at a sensitivity of  $10^{-4}$ , or even lower limits provided sufficient DNA is tested. The MRD software can also be used for simultaneous objective tracking of bi-allelic sequences across multiple replicates for longitudinal subject tracking and in drug development studies.

The provided software is composed of three distinct parts:

1. A bioinformatics Data Analysis Application
2. A Project Planner that can be used to calculate confidence based on read depth, replicate count, and DNA input
3. PDF report identifying the clonotype sequence if present and summarizing the degree of mismatches, calculating the read frequency and the degree of confidence if a certain clonotype is not present at sensitivities of  $10^{-3}$ ,  $10^{-4}$ ,  $10^{-5}$ , and  $10^{-6}$ .

## Minimum Software Requirements

- Processor: Intel Core 2 Duo or newer CPU recommended
- Hard Drive: At least 1 GB of free disk space is required; 2 GB recommended
- RAM: 4 GB required; 8 GB or more recommended
- Operating System: Windows 7 (64-bit)
- A CD-ROM drive\*

\* If a CD-ROM drive is not available, please contact us at: [support@invivoscribe.com](mailto:support@invivoscribe.com)

---

## MRD Project Planner

The Project Planner can be used to calculate the confidence of a true negative by adding replicate counts, resequencing counts, sequencing depth, and DNA input amount. The software assumes that the same sequencing depth and DNA input is used for each replicate.

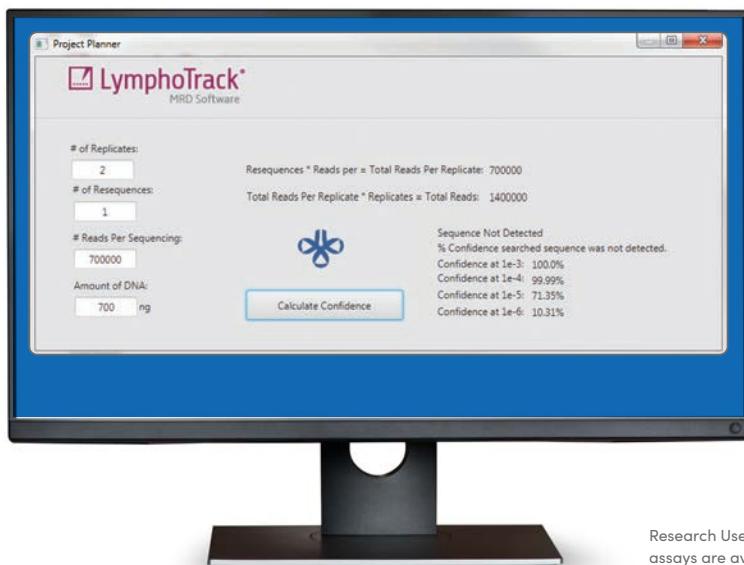

Research Use Only (RUO) assays are not for sale in Europe and other global markets where equivalent CE-IVD assays are available and registered with the appropriate regulatory agencies.

## LymphoTrack MRD Specimen Report

This report summarizes the overall call, i.e. if a clonotype was detected or not detected, the number of checked replicates, the total DNA input, total reads analyzed and the location of all output files. The values in the PDF report are also found in the generated text files.

Sequence #	1	Sequence Name	Sequence_1		
Replicate	1	MRD Status*	NOT DETECTED	Reads in Replicate	950000
<p>CAGCCTCTAGATTTCGTCTTTGATGATGTTGTCACTCCACTGACGCCACGCTCCAGGGAAGGGCCTGGAGAGACGCTGCAGAGGACGTCGTA GGAGCGCCTCCTAAAGAATCTTGAATACTGGGGCCGGGGAACCCCTGGTCACCGTGTCTCAGGTGAGTCTCGTCACCGTGTCTCACGTG AGTCCTCAGAACTGGGAACCT</p>					
Replicate Details	Cumulative Target Read Count	Cumulative % Total Reads	Cumulative LymphoQuant Read Count	Clonal Frequency	
Exact Match	1	NOT DETECTED	300	NOT DETECTED	
1 Mismatch	1	NOT DETECTED	300	NOT DETECTED	
2 Mismatch	1	NOT DETECTED	300	NOT DETECTED	
Detection Limit	% Confidence		Detection Limit	% Confidence	
1e-3	100.0%		1e-5	64.3%	
1e-4	99.99%		1e-6	3.53%	

## MRD Summary Graph

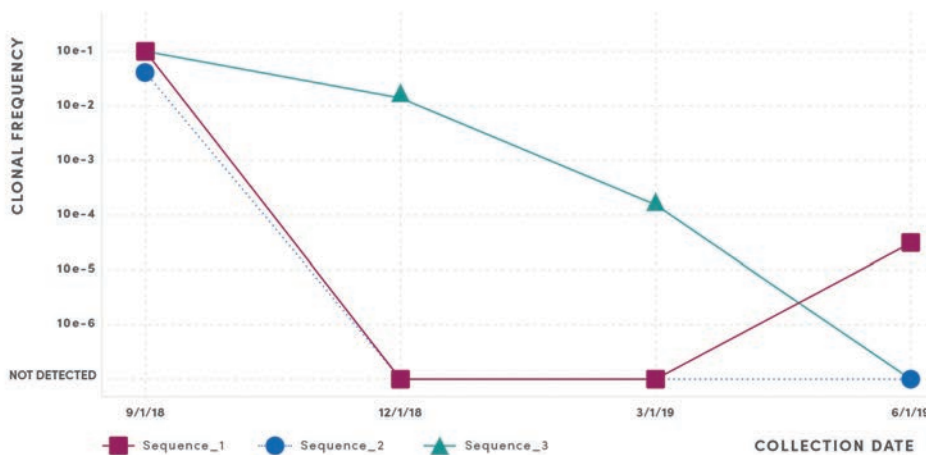

NOTE: The MRD Report may slightly differ from what is shown.

### Ordering Information

Catalog #	Products	Quantity Components
7-500-0008	LymphoTrack <sup>®</sup> MRD Software**	1 CD complimentary with LymphoTrack kit purchase

\*\* MRD Software can be used to track sequences generated using either LymphoTrack<sup>®</sup> Assays formatted for either the Illumina<sup>®</sup> or Thermo Fisher<sup>®</sup> NGS platforms.

MRD applications are for Research Use Only. To obtain a copy, please contact your local distributor or send an e-mail to customerservice@invivoscribe.com

## Low Positive Controls

Minimal Residual Disease (MRD) testing is a valuable tool that allows investigators to study and monitor multiple myeloma (MM), chronic lymphocytic leukemia (CLL), acute lymphoblastic leukemia (ALL), acute myelogenous leukemia (AML) and other hematologic diseases. Recent treatment advances have led to significantly increased clinical response and overall survival, but ultimately most subjects will relapse, driving the need for sensitive MRD monitoring. Sensitive and standardized testing such as NGS-based MRD may one day enable identification of those cases that will eventually relapse versus those who are potentially cured. In addition to the need for more sensitive tracking, it is clear that standardized methods are needed. Currently, MRD methods are highly subjective and recommendations are often based on consensus expert-shared knowledge and experience, not on a validated, objective method. Once specific rearrangements have been identified, LymphoTrack assays can be used with LymphoQuant and LymphoTrack Low Positive Controls to track these clonotype populations to a sensitivity as low as  $10^{-4}$ .

### LymphoTrack<sup>®</sup> B-cell Low Positive Control

LymphoTrack<sup>®</sup> B-cell Low Positive Control can be used as a control for:

Gene Rearrangements: *IGH, IGK*  
Chromosome Translocations: *n/c*  
Mutations: *n/c*

Catalog #	Description
4-088-0098	LymphoTrack <sup>®</sup> B-cell Low Positive Control

### LymphoTrack<sup>®</sup> T-cell Low Positive Control

LymphoTrack<sup>®</sup> T-cell Low Positive Control can be used as a control for:

Gene Rearrangements: *TRB, TRG*  
Chromosome Translocations: *n/c*  
Mutations: *n/c*

Catalog #	Description
4-088-0108	LymphoTrack <sup>®</sup> T-cell Low Positive Control

Note: Same product listed on page 138 in DNA controls section.

MRD applications are for Research Use Only (RUO); not intended for *in vitro* diagnostic use.



## Internal Controls

LymphoQuant T-cell or B-cell Internal Controls may be spiked into specimens to estimate the respective number of clonotype T-cell or B-cell equivalents present. Addition of the LymphoQuant Internal Control to the specimen PCR facilitates clonotype tracking over time without any additional sequencing cost. Consistent use of a LymphoQuant Internal Control enables investigators to objectively monitor the disease over time with a highly standardized, sensitive method. The LymphoTrack MRD software will help researchers that use the LymphoQuant Internal Control, calculate and report an estimated number of clonotype cell equivalents and the percent clonotype in the sample, enabling researchers and pharmaceutical companies to accurately monitor hematologic disease in longitudinal studies.

### LymphoQuant<sup>®</sup> B-cell Internal Control

LymphoQuant B-cell Internal Control can be used to objectively track Ig clonotypes.

Gene Rearrangements: *IGH, IGK*  
Chromosome Translocations: n/c  
Mutations: n/c

Catalog #	Description
4-088-0118	LymphoQuant <sup>®</sup> B-cell Internal Control

### LymphoQuant<sup>®</sup> T-cell Internal Control

LymphoQuant T-cell Internal Control can be used to objectively track TCR clonotypes.

Gene Rearrangements: *TRB, TRG*  
Chromosome Translocations: n/c  
Mutations: n/c

Catalog #	Description
4-088-0128	LymphoQuant <sup>®</sup> T-cell Internal Control

Note: Same product listed on page 139 in DNA controls section.

MRD applications are for Research Use Only (RUO); not intended for *in vitro* diagnostic use.



## Gel and Capillary CE IVD Assays

### B-Cell Assays

58 / IdentiClone *IGH + IGK*  
B-Cell Clonality Assays

60 / IdentiClone *IGH* Gene  
Clonality Assays

62 / IdentiClone *IGK* Gene  
Clonality Assays

64 / IdentiClone *IGL* Gene  
Clonality Assays

### Translocation Assays

76 / IdentiClone *BCL1/JH*  
Translocation Assays

78 / IdentiClone *BCL2/JH*  
Translocation Assays

### T-Cell Assays

66 / IdentiClone *TCRB + TCRG*  
T-Cell Clonality Assays

68 / IdentiClone *TCRB*  
Gene Clonality Assays

70 / IdentiClone T-Cell Receptor Gamma  
Gene Rearrangement Assay 2.0

72 / IdentiClone *TCRG*  
Gene Clonality Assays

74 / IdentiClone *TCRD*  
Gene Clonality Assays

#### WARRANTY AND LIABILITY

Invivoscribe, Inc. (Invivoscribe®) is committed to providing the highest quality products. Invivoscribe® warrants that the products meet or exceed the performance standards described in the Instructions For Use, as to products with such an insert. If a product is covered by product specifications and does not perform as specified, our policy is to replace the product or credit the full purchase price. No other warranties of any kind, expressed or implied, are provided by Invivoscribe®. Invivoscribe® liability shall not exceed the purchase price of the product. Invivoscribe® shall have no liability for direct, indirect, consequential or incidental damages arising from the use, results of use, or inability to use its products; product efficacy under purchaser controlled conditions in purchaser's laboratory must be established and continually monitored through purchaser defined and controlled processes including but not limited to testing of positive, negative, and blank controls every time a sample is tested. Ordering, acceptance, and use of product constitutes purchaser acceptance of sole responsibility for assuring product efficacy and purchaser agreement to the limitation of liability set forth in this paragraph.

NOTICE: The products in the section that follows are *in vitro* diagnostic products and are not available for sale or use within North America. Many of these products are covered by one or more of the following: European Patent Number 1549764, European Patent Number 2418287, European Patent Number 2460889, Japanese Patent Number 4708029, United States Patent 8859748, United States Patent 10280462, and related pending and future applications. All of these patents and applications are licensed exclusively to Invivoscribe®. Additional patents licensed to Invivoscribe covering some of these products apply elsewhere.

These products require nucleic acid amplification methods such as Polymerase Chain Reaction (PCR). No license under these patents to use amplification processes or enzymes is conveyed expressly or by implication to the purchaser by the purchase of these products.

Identiclone® is a registered trademark of Invivoscribe®.





## IdentiClone Assay kits are CE-marked *in vitro* diagnostic products.\*

These kits are intended for PCR-based detection of clonal gene rearrangements and translocations in patients with suspected lymphoproliferations, using gel or capillary electrophoresis methods.

These PCR-based tests include standardized Instructions For Use (IFUs) with interpretation guidelines describing the use of the kits' master mixes and controls. Master mixes are composed of a buffered magnesium chloride solution, deoxynucleotides, and multiple primers that target the gene segments of interest. Multiple primers are necessary to ensure a comprehensive testing approach that reliably identifies clonal rearrangements. These assay master mixes are complete with the exception of Taq DNA polymerase, which is not provided. A single thermal cycler program and similar detection methods are used within each IdentiClone kit to improve consistency, reduce human error, and facilitate cross-training.

These assays are available in regular (33 reactions) and in MegaKit formats (330 reactions).

For more information, please visit [www.invivoscribe.com](http://www.invivoscribe.com)

# IGH + IGK B-Cell Clonality Assays

## Assay Description

The IdentiClone IGH + IGK B-Cell Clonality Assays are *in vitro* diagnostic products intended for PCR-based detection of clonal immunoglobulin heavy chain and kappa light chain gene rearrangements in patients with suspect lymphoproliferations.

Specifically, the IdentiClone IGH + IGK B-Cell Clonality Assays can be used to:

- Identify clonality in atypical lymphoproliferative disorders
- Support a differential diagnosis between reactive lesions and hematologic malignancies
- Assign presumptive lineage in mature monoclonal lymphoproliferative disorders
- Identify tumor-specific markers (IGH and IGK gene rearrangements) for post-treatment monitoring
- Monitor and evaluate disease recurrence

## Summary and Explanation of the Test

The Inivoscribe CE-marked IdentiClone Assays represent a unique approach to PCR-based clonality testing. These standardized assays were carefully optimized, testing positive and negative control samples using multiplex master mixes. Assay development was followed by extensive validation including the testing of more than 400 clinical samples using Revised European/American Lymphoma (REAL) Classification. Testing was done at more than thirty prominent independent testing centers throughout Europe in a collaborative study known as the BIOMED-2 Concerted Action. Results from this BIOMED-2 study appear in *Leukemia*, a leading peer-reviewed journal.<sup>1</sup>

These kits include six master mixes to test for rearrangements of both IGH and IGK. The IGH Tube A, B, and C master mixes target the framework 1, 2, 3 regions (respectively) within the variable (V<sub>H</sub>) region, and the joining (J<sub>H</sub>) region of the immunoglobulin heavy chain locus. The IGK Tube A master mix targets the variable (V<sub>K</sub>) and the joining (J<sub>K</sub>) region. IGK Tube B master mix targets kappa deleting element (K<sub>de</sub>) rearrangements with the variable (V<sub>K</sub>) region and the intragenic J<sub>K</sub>-C<sub>K</sub> region. The resulting V<sub>K</sub>-K<sub>de</sub> and J<sub>K</sub>-C<sub>K</sub> intron-K<sub>de</sub> rearrangements are a result of unsuccessful rearrangements retained by the B cell. For best sensitivity, it is recommended to test suspect B-cell malignancies for both IGH and IGK.<sup>3</sup> The included Specimen Control Size Ladder master mix targets multiple genes and generates a series of amplicons of approximately 100, 200, 300, 400, and 600 base pairs to ensure that the quality and quantity of input DNA is adequate to yield a valid result.

A single thermal cycler program and similar detection methodologies are used with all of our Gene Clonality Assays. This improves consistency and facilitates cross-training on a broad range of different assays.

## Performance Characteristics

Data from two independent studies that tested more than 300 patient samples of varying types suggests the diagnostic accuracy of selected IdentiClone tests to be 96%. In both peer-reviewed studies, there were no clear false-positive results generated using the IdentiClone tests, and there was a high level of precision.<sup>2</sup>

The clinico-histopathological diagnosis correlated well with PCR results in a higher number of patients when compared with Southern Blot (SB) results, as seen below:

PCR/SB concordance:<sup>1</sup>

IGH:	93% sensitivity / 92% specificity
IGK:	90% sensitivity / 90% specificity
IGL:	86% sensitivity / 92% specificity
TRB:	86% sensitivity / 98% specificity
TRG:	89% sensitivity / 94% specificity
TRD:	83% sensitivity / 95% specificity

PCR vs. SB analysis relative to histopathology and final diagnosis:

	PCR/SB concordance: <sup>2</sup>	PCR sensitivity:	SB sensitivity:
IGH + IGK:	85%	98%	39%
TRB:	85%	96%	35%

## Reference

1. JJM van Dongen et al., *Leukemia* 17:2257-2317 (2003).
2. Y Sandberg et al., *J. Mol. Diag.* 7(4):495-503 (2005).
3. Van Krieken, JHJM et al., *Leukemia* 21:201 - 206 (2007).

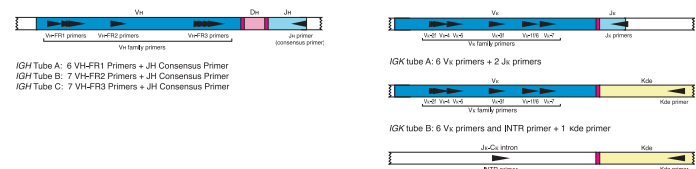

**Figure Legend:** Simple representation of the organization of a rearranged immunoglobulin heavy chain (IGH) gene on chromosome 14q32.33 and the immunoglobulin kappa light chain gene on chromosome 2p11.2. Black arrows represent the relative positions of primers that target the conserved framework regions (FR1-3) and the downstream consensus J<sub>H</sub> gene segments for IGH and the V<sub>K</sub>, J<sub>K</sub>, INTR and K<sub>de</sub> primers which are included in the IGK master mix tubes.

## Reagents

Controls	Concentration	Units in Assay	Units in Assay MegaKit
IVS-0030 Clonal Control DNA	200 µg/mL	1 x 100 µL tube	5 x 100 µL tubes
IVS-0019 Clonal Control DNA	200 µg/mL	1 x 100 µL tube	5 x 100 µL tubes
IVS-0007 Clonal Control DNA	200 µg/mL	1 x 100 µL tube	5 x 100 µL tubes
IVS-0000 Polyclonal Control DNA	200 µg/mL	1 x 100 µL tube	5 x 100 µL tubes
Master Mixes	Target	Units in Assay	Units in Assay MegaKit
IGH Tube A	Framework 1 + JH	1 x 1500 µL tube	10 x 1500 µL tubes
IGH Tube B	Framework 2 + JH	1 x 1500 µL tube	10 x 1500 µL tubes
IGH Tube C	Framework 3 + JH	1 x 1500 µL tube	10 x 1500 µL tubes
IGK Tube A	Vk-Jk	1 x 1500 µL tube	10 x 1500 µL tubes
IGK Tube B	Vk-Kde, Intron-Kde	1 x 1500 µL tube	10 x 1500 µL tubes
Specimen Control Size Ladder	Multiple Genes	1 x 1500 µL tube	10 x 1500 µL tubes

## Gel Electrophoresis Detection

Heteroduplex analysis is performed to differentiate clonal and non-clonal PCR products. It involves heat denaturation of double-stranded DNA, followed by a snap chilling process to force DNA strands to quickly reanneal. In non-clonal populations, this process causes the majority of the single-stranded DNA to incorrectly bind to non-homologous strands, resulting in secondary structures and reducing the DNA's ability to migrate through a non-denaturing polyacrylamide gel. As a result, polyclonal products are frequently observed as smears at high molecular weights. In clonal populations, after heteroduplex analysis is performed, most denatured single-strand PCR products will reanneal correctly with homologous strands of DNA (reforming homoduplexes) allowing them to easily migrate through the polyacrylamide gel as a single band. Therefore, heteroduplex analysis is key for analyzing PCR products visualized using gel detection methods, as it increases the separation between clonal and polyclonal products.

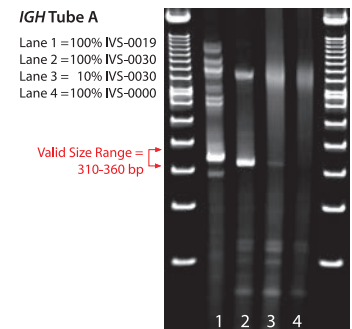

## Capillary Electrophoresis Detection (ABI)

Differential fluorescence detection, such as ABI fluorescence detection, is commonly used to resolve different-sized amplicon products using a capillary electrophoresis instrument. Primers can be conjugated with several different fluorescent dyes (fluorophores), so that they produce different emission spectra upon excitation by a laser in the capillary electrophoresis instrument. In this manner, different fluorescent dyes can correspond to different targeted regions. This detection system results in excellent sensitivity, single nucleotide resolution, differential product detection, and relative quantification. In addition, differential detection allows accurate, reproducible and objective interpretation of primer-specific products. Inter-assay and intra-assay reproducibility in size determination using capillary electrophoresis is approximately 1 to 4 nucleotides.

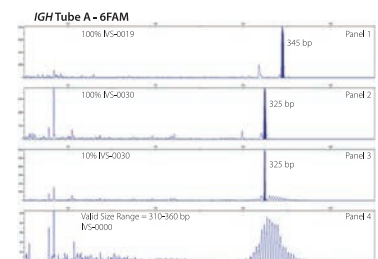

## Ordering Information

Catalog #	Products	Quantity
9-100-0010	IdentiClone <sup>®</sup> IGH + IGK B-Cell Clonality Assay - Gel Detection	33 reactions
9-100-0020	IdentiClone <sup>®</sup> IGH + IGK B-Cell Clonality Assay MegaKit - Gel Detection	330 reactions
9-100-0031	IdentiClone <sup>®</sup> IGH + IGK B-Cell Clonality Assay - ABI Fluorescence Detection	33 reactions
9-100-0041	IdentiClone <sup>®</sup> IGH + IGK B-Cell Clonality Assay MegaKit - ABI Fluorescence Detection	330 reactions

These are *in vitro* diagnostic products, and are not available for sale or use within North America.

# IGH Gene Clonality Assays

## Assay Description

The IdentiClone IGH Gene Clonality Assays are *in vitro* diagnostic products intended for PCR-based detection of clonal immunoglobulin heavy chain gene rearrangements in patients with suspect lymphoproliferations.

Specifically, the IdentiClone IGH Gene Clonality Assays can be used to:

- Identify clonality in atypical lymphoproliferative disorders
- Support a differential diagnosis between reactive lesions and hematologic malignancies
- Assign presumptive lineage in mature monoclonal lymphoproliferative disorders
- Identify tumor-specific markers (IGH gene rearrangements) for post-treatment monitoring
- Monitor and evaluate disease recurrence

## Summary and Explanation of the Test

The Invivoscribe CE-marked IdentiClone Assays represent a unique approach to PCR-based clonality testing. These standardized assays were carefully optimized, testing positive and negative control samples using multiplex master mixes. Assay development was followed by extensive validation including the testing of more than 400 clinical samples using Revised European/American Lymphoma (REAL) Classification. Testing was done at more than thirty prominent independent testing centers throughout Europe in a collaborative study known as the BIOMED-2 Concerted Action. Results from this BIOMED-2 study appear in *Leukemia*, a leading peer-reviewed journal.<sup>1</sup>

These test kits include six master mixes. The IGH Tube A, B, and C master mixes target the framework 1, 2, and 3 regions (respectively) within the variable (VH) region and the joining (JH) region of the immunoglobulin heavy chain locus. The IGH Tube D and E master mixes target the diversity and joining regions. The Specimen Control Size Ladder master mix targets multiple genes and generates a series of amplicons of approximately 100, 200, 300, 400, and 600 base pairs to ensure that the quality and quantity of input DNA is adequate to yield a valid result. A single thermal cycler program and similar detection methodologies are used with all of our gene clonality assays. This improves consistency and facilitates cross-training on a broad range of different assays.

## Performance Characteristics

Data from two independent studies that tested more than 300 patient samples of varying types suggests the diagnostic accuracy of selected IdentiClone tests to be 96%. In both peer-reviewed studies, there were no clear false-positive results generated using the IdentiClone tests, and there was a high level of precision.<sup>2</sup>

The clinico-histopathological diagnosis correlated well with PCR results in a higher number of patients when compared with Southern Blot (SB) results, as seen below:

	PCR/SB concordance: <sup>1</sup>
IGH:	93% sensitivity / 92% specificity
IGK:	90% sensitivity / 90% specificity
IGL:	86% sensitivity / 92% specificity
TRB:	86% sensitivity / 98% specificity
TRG:	89% sensitivity / 94% specificity
TRD:	83% sensitivity / 95% specificity

PCR vs. SB analysis relative to histopathology and final diagnosis:

	PCR/SB concordance: <sup>2</sup>	PCR sensitivity:	SB sensitivity:
IGH + IGK:	85%	98%	39%
TRB:	85%	96%	35%

## Reference

1. JJM van Dongen et al., *Leukemia* 17:2257-2317 (2003).
2. Y Sandberg et al., *J. Mol. Diag.* 7(4):495-503 (2005).

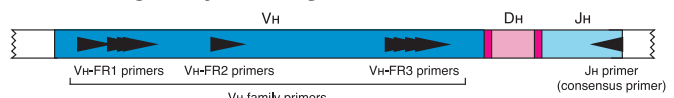

- Tube A: 6 V<sub>H</sub> -FR1 Primers + J<sub>H</sub> Consensus Primer
- Tube B: 7 V<sub>H</sub> -FR2 Primers + J<sub>H</sub> Consensus Primer
- Tube C: 7 V<sub>H</sub> -FR3 Primers + J<sub>H</sub> Consensus Primer

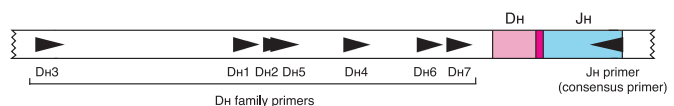

- Tube D: 6 D<sub>H</sub> Primers + J<sub>H</sub> Consensus Primer
- Tube E: D<sub>H</sub> 7 Primer + J<sub>H</sub> Consensus Primer

**Figure Legend:** Simple representation of the organization of a rearranged immunoglobulin heavy chain gene on chromosome 14q32.33. Black arrows represent the relative positions of primers that target the conserved framework (FR1-3) and diversity (Dh1-7) regions, and the downstream consensus JH gene segments. The amplicon products generated from each of these regions can be differentially detected when fluorescent primer sets are used with capillary electrophoresis instruments that employ differential fluorescence detection.

## Reagents

Controls	Concentration	Units in Assay	Units in Assay MegaKit
IVS-0030 Clonal Control DNA	200 µg/mL	1 x 100 µL tube	5 x 100 µL tubes
IVS-0019 Clonal Control DNA	200 µg/mL	1 x 100 µL tube	5 x 100 µL tubes
IVS-0024 Clonal Control DNA	200 µg/mL	1 x 100 µL tube	5 x 100 µL tubes
IVS-0008 Clonal Control DNA	200 µg/mL	1 x 100 µL tube	5 x 100 µL tubes
IVS-0000 Polyclonal Control DNA	200 µg/mL	1 x 100 µL tube	5 x 100 µL tubes
Master Mixes	Target	Units in Assay	Units in Assay MegaKit
IGH Tube A	Framework 1 + JH	1 x 1500 µL tube	10 x 1500 µL tubes
IGH Tube B	Framework 2 + JH	1 x 1500 µL tube	10 x 1500 µL tubes
IGH Tube C	Framework 3 + JH	1 x 1500 µL tube	10 x 1500 µL tubes
IGH Tube D	DH1-6 + JH	1 x 1500 µL tube	10 x 1500 µL tubes
IGH Tube E	DH7 + JH	1 x 1500 µL tube	10 x 1500 µL tubes
Specimen Control Size Ladder	Multiple Genes	1 x 1500 µL tube	10 x 1500 µL tubes

## Gel Electrophoresis Detection

Heteroduplex analysis is performed to differentiate clonal and non-clonal PCR products and involves heat denaturation of double-stranded DNA, followed by a snap chilling process to force DNA strands to quickly reanneal. In non-clonal populations, this process causes a majority of the single-stranded DNA to incorrectly bind to non-homologous strands resulting in secondary structures and reducing the DNA's ability to migrate through a non-denaturing polyacrylamide gel. As a result, polyclonal products are frequently observed as smears at high molecular weights. In clonal populations, after heteroduplex analysis is performed, most denatured single-strand PCR products will reanneal correctly with homologous strands of DNA (reforming homoduplexes) allowing them to easily migrate through the polyacrylamide gel as a single band. Therefore, heteroduplex analysis is key for analyzing PCR products visualized using gel detection methods as it increases the separation between clonal and polyclonal products.

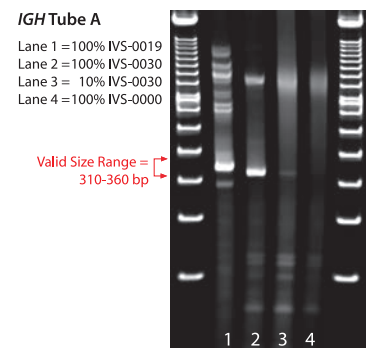

## Capillary Electrophoresis Detection (ABI)

Differential fluorescence detection, such as ABI fluorescence detection, is commonly used to resolve different-sized amplicon products using a capillary electrophoresis instrument. Primers can be conjugated with several different fluorescent dyes (fluorophores), so that they produce different emission spectra upon excitation by a laser in the capillary electrophoresis instrument. In this manner, different fluorescent dyes can correspond to different targeted regions. This detection system results in excellent sensitivity, single nucleotide resolution, differential product detection, and relative quantification. In addition, differential detection allows accurate, reproducible and objective interpretation of primer-specific products. Inter-assay and intra-assay reproducibility in size determination using capillary electrophoresis is approximately 1 to 4 nucleotides.

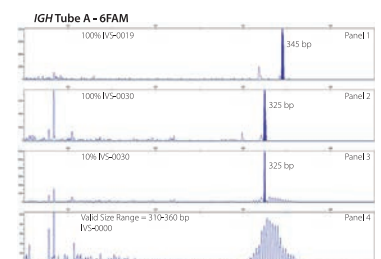

## Ordering Information

Catalog #	Products	Quantity
9-101-0020	IdentiClone <sup>®</sup> IGH Gene Clonality Assay - Gel Detection	33 reactions
9-101-0040	IdentiClone <sup>®</sup> IGH Gene Clonality Assay MegaKit - Gel Detection	330 reactions
9-101-0061	IdentiClone <sup>®</sup> IGH Gene Clonality Assay - ABI Fluorescence Detection	33 reactions
9-101-0081	IdentiClone <sup>®</sup> IGH Gene Clonality Assay MegaKit - ABI Fluorescence Detection	330 reactions

These are *in vitro* diagnostic products, and are not available for sale or use within North America.

# IGK Gene Clonality Assays

## Assay Description

The IdentiClone IGK Gene Clonality Assays are *in vitro* diagnostic products intended for PCR-based detection of clonal immunoglobulin kappa light chain gene rearrangements in patients with suspect lymphoproliferations.

Specifically, the IdentiClone IGK Gene Clonality Assays can be used to:

- Identify clonality in atypical lymphoproliferative disorders
- Support a differential diagnosis between reactive lesions and hematologic malignancies
- Assign presumptive lineage in mature monoclonal lymphoproliferative disorders
- Identify tumor-specific markers (*IGK* and *IGK-K<sub>de</sub>* rearrangements) for post-treatment monitoring
- Monitor and evaluate disease recurrence

## Summary and Explanation of the Test

The Invivoscribe CE-marked IdentiClone Assays represent a unique approach to PCR-based clonality testing. These standardized assays were carefully optimized testing positive and negative control samples using multiplex master mixes. Assay development was followed by extensive validation including the testing of more than 400 clinical samples using Revised European/American Lymphoma (REAL) Classification. Testing was done at more than thirty prominent independent testing centers throughout Europe in a collaborative study known as the BIOMED-2 Concerted Action. Results from this BIOMED-2 study appear in *Leukemia*, a leading peer-reviewed journal.<sup>1</sup>

These test kits include three master mixes. The *IGK* Tube A master mix targets the variable (*V<sub>k</sub>*) and the joining (*J<sub>k</sub>*) regions of the immunoglobulin kappa light chain locus, whereas the *IGK* Tube B master mix targets kappa deleting element (*K<sub>de</sub>*) rearrangements with the *V<sub>k</sub>* regions and the intragenic *J<sub>k</sub>-C<sub>k</sub>* regions. The *V<sub>k</sub>-K<sub>de</sub>* and *J<sub>k</sub>-C<sub>k</sub>* intron-*K<sub>de</sub>* rearrangements are a result of unsuccessful rearrangements retained by the B cell. The third master mix, the Specimen Control Size Ladder, targets multiple genes and generates a series of amplicons of approximately 100, 200, 300, 400, and 600 base pairs to ensure that the quality and quantity of input DNA is adequate to yield a valid result. A single thermal cycler program and similar detection methodologies are used with all of our gene clonality assays. This improves consistency and facilitates cross-training.

## Performance Characteristics

Data from two independent studies that tested more than 300 patient sample of varying types suggests the diagnostic accuracy of selected IdentiClone tests to be 96%. In both peer-reviewed studies, there were no clear false-positive results generated using the IdentiClone tests, and there was a high level of precision.<sup>2</sup>

The clinico-histopathological diagnosis correlated well with PCR results in a higher number of patients when compared with Southern Blot (SB) results, as seen below:

	PCR/SB concordance: <sup>1</sup>
<i>IGH</i> :	93% sensitivity / 92% specificity
<i>IGK</i> :	90% sensitivity / 90% specificity
<i>IGL</i> :	86% sensitivity / 92% specificity
<i>TRB</i> :	86% sensitivity / 98% specificity
<i>TRG</i> :	89% sensitivity / 94% specificity
<i>TRD</i> :	83% sensitivity / 95% specificity

PCR vs. SB analysis relative to histopathology and final diagnosis:

	PCR/SB concordance: <sup>2</sup>	PCR sensitivity:	SB sensitivity:
<i>IGH + IGK</i> :	85%	98%	39%
<i>TRB</i> :	85%	96%	35%

## Reference

1. JJM van Dongen et al., *Leukemia* 17:2257-2317 (2003).
2. Y Sandberg et al., *J. Mol. Diag.* 7(4):495-503 (2005).

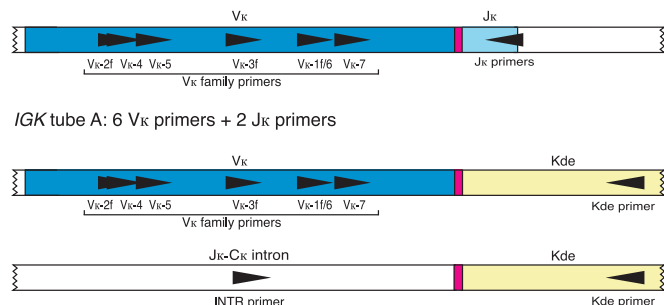

**IGK tube B: 6 V<sub>k</sub> primers and INTR primer + 1 Kde primer**

**Figure Legend:** Schematic diagram of the immunoglobulin kappa light chain gene complex on chromosome 2p11.2. Shown are the relative positions and orientations for the *V<sub>k</sub>-J<sub>k</sub>* and *K<sub>de</sub>* primers, which are included in the *IGK* master mix tubes.

## Reagents

Controls	Concentration	Units in Assay	Units in Assay MegaKit
IVS-0007 Clonal Control DNA	200 µg/mL	1 x 100 µL tube	5 x 100 µL tubes
IVS-0000 Polyclonal Control DNA	200 µg/mL	1 x 100 µL tube	5 x 100 µL tubes
Master Mixes	Target	Units in Assay	Units in Assay MegaKit
<i>IGK</i> Tube A	V <sub>k</sub> - J <sub>k</sub>	1 x 1500 µL tube	10 x 1500 µL tubes
<i>IGK</i> Tube B	V <sub>k</sub> -K <sub>dey</sub> , Intron-K <sub>de</sub>	1 x 1500 µL tube	10 x 1500 µL tubes
Specimen Control Size Ladder	Multiple Genes	1 x 1500 µL tube	10 x 1500 µL tubes

## Gel Electrophoresis Detection

Heteroduplex analysis is performed to differentiate clonal and non-clonal PCR products. It involves heat denaturation of double-stranded DNA, followed by a snap chilling process to force DNA strands to quickly reanneal. In non-clonal populations, this process causes the majority of the single-stranded DNA to incorrectly bind to non-homologous strands, resulting in secondary structures and reducing the DNA's ability to migrate through a non-denaturing polyacrylamide gel. As a result, polyclonal products are frequently observed as smears at high molecular weights. In clonal populations, after heteroduplex analysis is performed, most denatured single-strand PCR products will reanneal correctly with homologous strands of DNA (reforming homoduplexes), allowing them to easily migrate through the polyacrylamide gel as a single band. Therefore, heteroduplex analysis is key for analyzing PCR products visualized using gel detection methods, as it increases the separation between clonal and polyclonal products.

### *IGK* Tube A

Lane 1 = 100% IVS-0019  
 Lane 2 = 100% IVS-0007  
 Lane 3 = 10% IVS-0007  
 Lane 4 = 100% IVS-0000

Valid Size Range =  
 120-160 bp,  
 190-210 bp,  
 & 260-300 bp

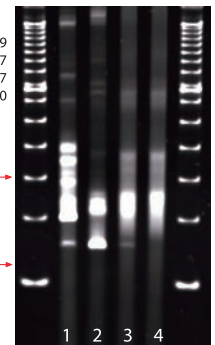

## Capillary Electrophoresis Detection (ABI)

Differential fluorescence detection, such as ABI fluorescence detection, is commonly used to resolve different-sized amplicon products using a capillary electrophoresis instrument. Primers can be conjugated with several different fluorescent dyes (fluorophores), so that they produce different emission spectra upon excitation by a laser in the capillary electrophoresis instrument. In this manner, different fluorescent dyes can correspond to different targeted regions. This detection system results in excellent sensitivity, single nucleotide resolution, differential product detection, and relative quantification. In addition, differential detection allows accurate, reproducible and objective interpretation of primer-specific products. Inter-assay and intra-assay reproducibility in size determination using capillary electrophoresis is approximately 1 to 4 nucleotides.

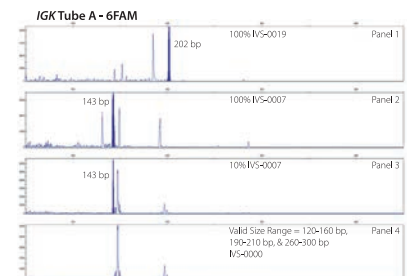

## Ordering Information

Catalog #	Products	Quantity
9-102-0020	IdentiClone <sup>®</sup> <i>IGK</i> Gene Clonality Assay - Gel Detection	33 reactions
9-102-0030	IdentiClone <sup>®</sup> <i>IGK</i> Gene Clonality Assay MegaKit - Gel Detection	330 reactions
9-102-0021	IdentiClone <sup>®</sup> <i>IGK</i> Gene Clonality Assay - ABI Fluorescence Detection	33 reactions
9-102-0031	IdentiClone <sup>®</sup> <i>IGK</i> Gene Clonality Assay MegaKit - ABI Fluorescence Detection	330 reactions

These are *in vitro* diagnostic products, and are not available for sale or use within North America.

# IGL Gene Clonality Assays

## Assay Description

The IdentiClone *IGL* Gene Clonality Assays are *in vitro* diagnostic products intended for PCR-based detection of clonal immunoglobulin lambda light chain gene rearrangements in patients with suspect lymphoproliferations.

Specifically, the IdentiClone *IGL* Gene Clonality Assays can be used to:

- Identify clonality in atypical lymphoproliferative disorders
- Support a differential diagnosis between reactive lesions and hematologic malignancies
- Assign presumptive lineage in mature monoclonal lymphoproliferative disorders
- Identify tumor-specific markers (*IGL* gene rearrangements) for post-treatment monitoring
- Monitor and evaluate disease recurrence

## Summary and Explanation of the Test

The Invivoscribe CE-marked IdentiClone Assays represent a unique approach to PCR-based clonality testing. These standardized assays were carefully optimized testing positive and negative control samples using multiplex master mixes. Assay development was followed by extensive validation including the testing of more than 400 clinical samples using Revised European/American Lymphoma (REAL) Classification. Testing was done at more than thirty prominent independent testing centers throughout Europe in a collaborative study known as the BIOMED-2 Concerted Action. Results from this BIOMED-2 study appear in *Leukemia*, a leading peer-reviewed journal.<sup>1</sup>

These test kits include two master mixes. The *IGL* Tube master mix targets the variable (*V<sub>λ</sub>*) region and the joining (*J<sub>λ</sub>*) region of the immunoglobulin lambda light chain gene locus (*IGL*). The Specimen Control Size Ladder targets multiple genes and generates a series of amplicons of approximately 100, 200, 300, 400, and 600 base pairs to ensure that the quality and quantity of input DNA is adequate to yield a valid result. A single thermal cycler program and similar detection methodologies are used with all of our gene clonality assays. This improves consistency and facilitates cross-training.

## Performance Characteristics

Data from two independent studies that tested more than 300 patient samples of varying types suggests the diagnostic accuracy of selected IdentiClone tests to be 96%. In both peer-reviewed studies, there were no clear false-positive results generated using the IdentiClone tests, and there was a high level of precision.<sup>2</sup>

The clinico-histopathological diagnosis correlated well with PCR results in a higher number of patients when compared with Southern Blot (SB) results, as seen below:

	PCR/SB concordance: <sup>1</sup>
<i>IGH</i> :	93% sensitivity / 92% specificity
<i>IGK</i> :	90% sensitivity / 90% specificity
<i>IGL</i> :	86% sensitivity / 92% specificity
<i>TRB</i> :	86% sensitivity / 98% specificity
<i>TRG</i> :	89% sensitivity / 94% specificity
<i>TRD</i> :	83% sensitivity / 95% specificity

PCR vs. SB analysis relative to histopathology and final diagnosis:

	PCR/SB concordance: <sup>2</sup>	PCR sensitivity:	SB sensitivity:
<i>IGH + IGK</i> :	85%	98%	39%
<i>TRB</i> :	85%	96%	35%

## Reference

1. JJM van Dongen et al., *Leukemia* 17:2257-2317 (2003).
2. Y Sandberg et al., *J. Mol. Diag.* 7(4):495-503 (2005).

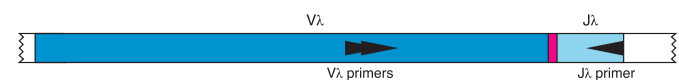

*IGL* tube: 2 *V<sub>λ</sub>* primers + 1 *J<sub>λ</sub>* primer

**Figure Legend:** Schematic diagram of the immunoglobulin lambda light chain gene complex on chromosome 22q11.2. Shown are the relative positions and orientations for the *V<sub>λ</sub>* and *J<sub>λ</sub>* primers, which are included in the *IGL* master mix tube. The two *V<sub>λ</sub>* primers only target *V<sub>λ</sub>*1, 2, and 3 because these three *V* families cover approximately 70% of rearrangeable *V<sub>λ</sub>* gene segments, and approximately 90% of all *IGL* gene rearrangements involve these three families. Similarly, the single *J<sub>λ</sub>* primer only targets *J<sub>λ</sub>*1, 2, and 3 because these three *J* segments are involved in 98% of all *IGL* gene rearrangements.



## Reagents

Controls	Concentration	Units in Assay	Units in Assay MegaKit
IVS-0010 Clonal Control DNA	200 µg/mL	1 x 100 µL tube	5 x 100 µL tubes
IVS-0029 Clonal Control DNA	200 µg/mL	1 x 100 µL tube	5 x 100 µL tubes
IVS-0000 Polyclonal Control DNA	200 µg/mL	1 x 100 µL tube	5 x 100 µL tubes
Master Mixes	Target	Units in Assay	Units in Assay MegaKit
IGL Tube	Vλ -Jλ	1 x 1500 µL tube	10 x 1500 µL tubes
Specimen Control Size Ladder	Multiple Genes	1 x 1500 µL tube	10 x 1500 µL tubes

## Gel Electrophoresis Detection

Heteroduplex analysis is performed to differentiate clonal and non-clonal PCR products. It involves heat denaturation of double-stranded DNA, followed by a snap chilling process to force DNA strands to quickly reanneal. In non-clonal populations, this process causes a majority of the single-stranded DNA to incorrectly bind to non-homologous strands, resulting in secondary structures and reducing the DNA's ability to migrate through a non-denaturing polyacrylamide gel. As a result, polyclonal products are frequently observed as smears at high molecular weights. In clonal populations, after heteroduplex analysis is performed, most denatured single-strand PCR products will reanneal correctly with homologous strands of DNA (reforming homoduplexes), allowing them to easily migrate through the polyacrylamide gel as a single band. Therefore, heteroduplex analysis is key for analyzing PCR products visualized using gel detection methods, as it increases the separation between clonal and polyclonal products.

### IGL Tube

Lane 1 = 100% IVS-0029  
Lane 2 = 100% IVS-0010  
Lane 3 = 10% IVS-0010  
Lane 4 = 100% IVS-0000

Valid Size Range =  
135-170 bp

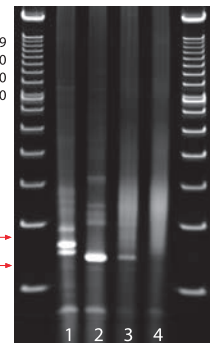

## Capillary Electrophoresis Detection (ABI)

Differential fluorescence detection, such as ABI fluorescence detection, is commonly used to resolve different-sized amplicon products using a capillary electrophoresis instrument. Primers can be conjugated with several different fluorescent dyes (fluorophores), so that they produce different emission spectra upon excitation by a laser in the capillary electrophoresis instrument. In this manner, different fluorescent dyes can correspond to different targeted regions. This detection system results in excellent sensitivity, single nucleotide resolution, differential product detection, and relative quantification. In addition, differential detection allows accurate, reproducible and objective interpretation of primer-specific products. Inter-assay and intra-assay reproducibility in size determination using capillary electrophoresis is approximately 1 to 4 nucleotides.

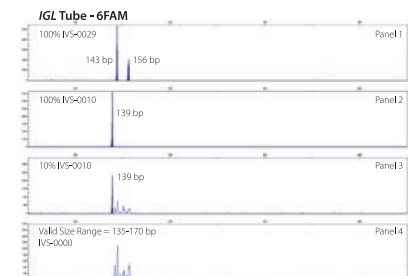

## Ordering Information

Catalog #	Products	Quantity
9-103-0010	IdentiClone <sup>®</sup> IGL Gene Clonality Assay - Gel Detection	33 reactions
9-103-0020	IdentiClone <sup>®</sup> IGL Gene Clonality Assay MegaKit - Gel Detection	330 reactions
9-103-0011	IdentiClone <sup>®</sup> IGL Gene Clonality Assay - ABI Fluorescence Detection	33 reactions
9-103-0021	IdentiClone <sup>®</sup> IGL Gene Clonality Assay MegaKit - ABI Fluorescence Detection	330 reactions

These are *in vitro* diagnostic products, and are not available for sale or use within North America.

# TCRB + TCRG T-Cell Clonality Assays

## Assay Description

The IdentiClone *TCRB* + *TCRG* T-Cell Clonality Assays are *in vitro* diagnostic products intended for PCR-based detection of clonal T-cell receptor beta and gamma chain gene rearrangements in patients with suspect lymphoproliferations.

Specifically, the IdentiClone *TCRB* + *TCRG* T-Cell Clonality Assays can be used to:

- Identify clonality in suspected lymphoproliferations
- Support a differential diagnosis between reactive lesions and T-cell and some immature B-cell malignancies
- Determine lineage involvement in mature lymphoproliferative disorders
- Monitor and evaluate disease recurrence

## Summary and Explanation of the Test

The Invivoscribe CE-marked IdentiClone Assays represent a unique approach to PCR-based clonality testing. These standardized assays were carefully optimized testing positive and negative control samples using multiplex master mixes. Assay development was followed by extensive validation including the testing of more than 400 clinical samples using Revised European/American Lymphoma (REAL) Classification. Testing was done at more than thirty prominent independent testing centers throughout Europe in a collaborative study known as the BIOMED-2 Concerted Action. Results from this BIOMED-2 study appear in *Leukemia*, a leading peer-reviewed journal.<sup>1</sup>

These kits include six master mixes to test for rearrangements of both *TRB* (formerly known as *TCRB*) and *TRG* (formerly known as *TCRG*). *TCRB* Tubes A and B target framework regions within the variable region, and the joining region of the *TCR* beta chain locus. *TCRB* Tube C targets the diversity and joining regions of the *TCR* beta chain locus. *TCRG* Tube A contains primers that target the *Vy*1-8 + *Vy*10 genes and *Jy*1.1, *Jy*1.3, *Jy*2.1, and *Jy*2.3 genes (also known as *JyP*1, *Jy*1, *JyP*2, and *Jy*2 respectively). *TCRG* Tube B contains primers that target the *Vy*9 + *Vy*11 genes and *Jy*1.1, *Jy*1.3, *Jy*2.1, and *Jy*2.3 genes. For best sensitivity it is recommended to test suspect T-cell malignancies for both *TRG* and *TRB*.<sup>3</sup> The Specimen Control Size Ladder master mix included targets multiple genes and generates a series of amplicons of approximately 100, 200, 300, 400, and 600 base pairs to ensure that the quality and quantity of input DNA is adequate to yield a valid result. A single thermal cycler program and similar detection

methodologies are used with all of our gene clonality assays. This improves consistency and facilitates cross-training on a broad range of different assays.

## Performance Characteristics

Data from two independent studies that tested more than 300 patient samples of varying types suggests the diagnostic accuracy of selected IdentiClone tests to be 96%. In both peer-reviewed studies, there were no clear false-positive results generated using the IdentiClone tests, and there was a high level of precision.<sup>2</sup> The clinico-histopathological diagnosis correlated well with PCR results in a higher number of patients when compared with Southern Blot (SB) results, as seen below:

	PCR/SB concordance: <sup>1</sup>
<i>IGH</i> :	93% sensitivity / 92% specificity
<i>IGK</i> :	90% sensitivity / 90% specificity
<i>IGL</i> :	86% sensitivity / 92% specificity
<i>TRB</i> :	86% sensitivity / 98% specificity
<i>TRG</i> :	89% sensitivity / 94% specificity
<i>TRD</i> :	83% sensitivity / 95% specificity

PCR vs. SB analysis relative to histopathology and final diagnosis:

	PCR/SB concordance: <sup>2</sup>	PCR sensitivity:	SB sensitivity:
<i>IGH</i> + <i>IGK</i> :	85%	98%	39%
<i>TRB</i> :	85%	96%	35%

## Reference

1. JJM van Dongen et al., *Leukemia* 17:2257-2317 (2003).
2. Y Sandberg et al., *J. Mol. Diag.* 7(4):495-503 (2005).
3. Van Krieken, JHJM et al., *Leukemia* 21:201 - 206 (2007).

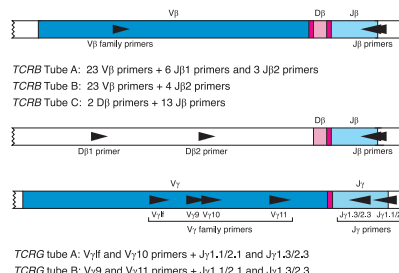

**Figure Legend:** Simplified diagram of a representative rearranged T-cell receptor beta gene and the T-cell receptor gamma gene showing the approximate placement of the upstream and downstream DNA primers. The numbers of primers and their specificity are listed for master mix *TCRB* Tubes A, B, and C and *TCRG* Tubes A and B. (The *Vy*1f primer is a consensus primer that targets *Vy*1 through *Vy*8).

## Reagents

Controls	Concentration	Units in Assay	Units in Assay MegaKit
IVS-0009 Clonal Control DNA	200 µg/mL	1 x 100 µL tube	5 x 100 µL tubes
IVS-0004 Clonal Control DNA	200 µg/mL	1 x 100 µL tube	5 x 100 µL tubes
IVS-0021 Clonal Control DNA	200 µg/mL	1 x 100 µL tube	5 x 100 µL tubes
IVS-0000 Polyclonal Control DNA	200 µg/mL	1 x 100 µL tube	5 x 100 µL tubes
Master Mixes	Target	Units in Assay	Units in Assay MegaKit
TCRB Tube A	Multiple Vβ + Jβ1/2	1 x 1500 µL tube	10 x 1500 µL tubes
TCRB Tube B	Multiple Vβ + Jβ2	1 x 1500 µL tube	10 x 1500 µL tubes
TCRB Tube C	Multiple Dβ + Jβ1/2	1 x 1500 µL tube	10 x 1500 µL tubes
TCRG Tube A	Vγβ1-8 + Vy10 + Jγ	1 x 1500 µL tube	10 x 1500 µL tubes
TCRG Tube B	Vy9 + Vy11 + Jγ	1 x 1500 µL tube	10 x 1500 µL tubes
Specimen Control Size Ladder	Multiple Genes	1 x 1500 µL tube	10 x 1500 µL tubes

## Gel Electrophoresis Detection

Heteroduplex analysis is performed to differentiate clonal and non-clonal PCR products. It involves heat denaturation of double-stranded DNA, followed by a snap chilling process to force DNA strands to quickly reanneal. In non-clonal populations, this process causes a majority of the single-stranded DNA to incorrectly bind to non-homologous strands, resulting in secondary structures and reducing the DNA's ability to migrate through a non-denaturing polyacrylamide gel. As a result, polyclonal products are frequently observed as smears at high molecular weights. In clonal populations, after heteroduplex analysis is performed, most denatured single-strand PCR products will reanneal correctly with homologous strands of DNA (reforming homoduplexes), allowing them to easily migrate through the polyacrylamide gel as a single band. Therefore, heteroduplex analysis is key for analyzing PCR products visualized using gel detection methods, as it increases the separation between clonal and polyclonal products.

### TCRB Tube A

Lane 1 = 100% IVS-0004  
Lane 2 = 100% IVS-0009  
Lane 3 = 10% IVS-0009  
Lane 4 = 100% IVS-0000

Valid Size Range =  
240-285 bp

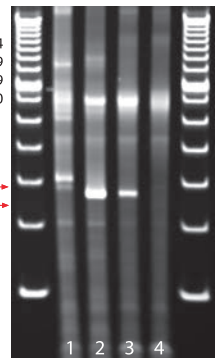

## Capillary Electrophoresis Detection (ABI)

Differential fluorescence detection, such as ABI fluorescence detection, is commonly used to resolve different-sized amplicon products using a capillary electrophoresis instrument. Primers can be conjugated with several different fluorescent dyes (fluorophores), so that they produce different emission spectra upon excitation by a laser in the capillary electrophoresis instrument. In this manner, different fluorescent dyes can correspond to different targeted regions. This detection system results in excellent sensitivity, single nucleotide resolution, differential product detection, and relative quantification. In addition, differential detection allows accurate, reproducible and objective interpretation of primer-specific products. Inter-assay and intra-assay reproducibility in size determination using capillary electrophoresis is approximately 1 to 4 nucleotides.

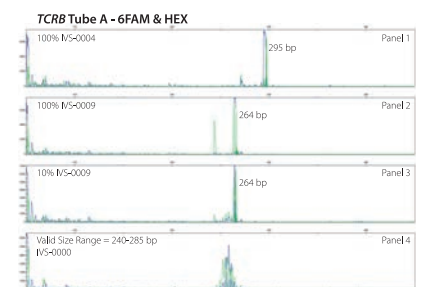

## Ordering Information

Catalog #	Products	Quantity
9-200-0010	IdentiClone <sup>®</sup> TCRB + TCRG T-Cell Clonality Assay - Gel Detection	33 reactions
9-200-0020	IdentiClone <sup>®</sup> TCRB + TCRG T-Cell Clonality Assay MegaKit - Gel Detection	330 reactions
9-200-0011	IdentiClone <sup>®</sup> TCRB + TCRG T-Cell Clonality Assay - ABI Fluorescence Detection	33 reactions
9-200-0021	IdentiClone <sup>®</sup> TCRB + TCRG T-Cell Clonality Assay MegaKit - ABI Fluorescence Detection	330 reactions

These are *in vitro* diagnostic products, and are not available for sale or use within North America.

## TCRB Gene Clonality Assays

### Assay Description

The IdentiClone TCRB Gene Clonality Assays are *in vitro* diagnostic products intended for PCR-based detection of clonal T-cell receptor beta chain gene rearrangements in patients with suspect lymphoproliferations.

Specifically, the IdentiClone TCRB Gene Clonality Assay can be used to:

- Identify clonality in suspected lymphoproliferations
- Support a differential diagnosis between reactive lesions and T-cell and some immature B-cell malignancies
- Determine lineage involvement in mature lymphoproliferative disorders
- Monitor and evaluate disease recurrence

### Summary and Explanation of the Test

The Invivoscribe CE-marked IdentiClone Assays represent a unique approach to PCR-based clonality testing. These standardized assays were carefully optimized testing positive and negative control samples using multiplex master mixes. Assay development was followed by extensive validation including the testing of more than 400 clinical samples using Revised European/American Lymphoma (REAL) Classification. Testing was done at more than thirty prominent independent testing centers throughout Europe in a collaborative study known as the BIOMED-2 Concerted Action. Results from this BIOMED-2 study appear in *Leukemia*, a leading peer-reviewed journal.<sup>1</sup>

These kits include four master mixes. TCRB Tubes A and B target framework regions within the variable region, and the joining region ( $V\beta$ ) of the TCR beta chain locus. TCRB Tube C targets the diversity and joining ( $J\beta$ ) regions of the TCR beta chain locus. The Specimen Control Size Ladder master mix included targets multiple genes and generates a series of amplicons of approximately 100, 200, 300,

400, and 600 base pairs to ensure that the quality and quantity of input DNA is adequate to yield a valid result. A single thermal cycler program and similar detection methodologies are used with all of our Gene Clonality Assays. This improves consistency and facilitates cross-training on a broad range of different assays.

### Performance Characteristics

Data from two independent studies that tested more than 300 patient samples of varying types suggests the diagnostic accuracy of selected IdentiClone tests to be 96%. In both peer-reviewed studies, there were no clear false-positive results generated using the IdentiClone tests, and there was a high level of precision.<sup>2</sup> The clinico-histopathological diagnosis correlated well with PCR results in a higher number of patients when compared with Southern Blot (SB) results, as seen below:

	PCR/SB concordance: <sup>1</sup>
IGH:	93% sensitivity / 92% specificity
IGK:	90% sensitivity / 90% specificity
IGL:	86% sensitivity / 92% specificity
TRB:	86% sensitivity / 98% specificity
TRG:	89% sensitivity / 94% specificity
TRD:	83% sensitivity / 95% specificity

PCR vs. SB analysis relative to histopathology and final diagnosis:

	PCR/SB concordance: <sup>2</sup>	PCR sensitivity:	SB sensitivity:
IGH + IGK:	85%	98%	39%
TRB:	85%	96%	35%

### Reference

1. JJM van Dongen et al., *Leukemia* 17:2257-2317 (2003).
2. Y Sandberg et al., *J. Mol. Diag.* 7(4):495-503 (2005).

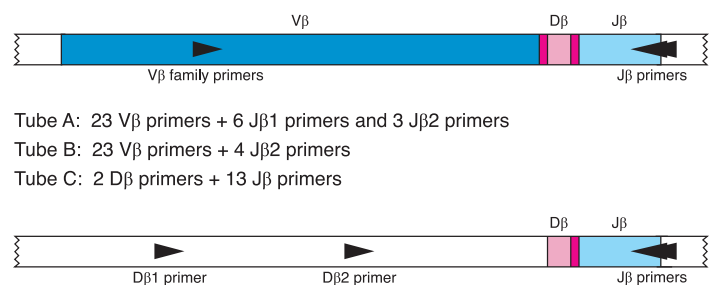

Tube A: 23  $V\beta$  primers + 6  $J\beta 1$  primers and 3  $J\beta 2$  primers

Tube B: 23  $V\beta$  primers + 4  $J\beta 2$  primers

Tube C: 2  $D\beta$  primers + 13  $J\beta$  primers

**Figure Legend:** Simplified diagram of a representative rearranged T-cell receptor beta gene showing the approximate placement of the upstream and downstream DNA primers. The numbers of primers and their specificity are listed for Master Mix Tubes A, B, and C.

## Reagents

Controls	Concentration	Units in Assay	Units in Assay MegaKit
IVS-0009 Clonal Control DNA	200 µg/mL	1 x 100 µL tube	5 x 100 µL tubes
IVS-0004 Clonal Control DNA	200 µg/mL	1 x 100 µL tube	5 x 100 µL tubes
IVS-0000 Polyclonal Control DNA	200 µg/mL	1 x 100 µL tube	5 x 100 µL tubes
IVS-0021 Clonal Control DNA	200 µg/mL	1 x 100 µL tube	5 x 100 µL tubes
Master Mixes	Target	Units in Assay	Units in Assay MegaKit
TCRB Tube A	Multiple Vβ + Jβ1/2	1 x 1500 µL tube	10 x 1500 µL tubes
TCRB Tube B	Multiple Vβ + Jβ2	1 x 1500 µL tube	10 x 1500 µL tubes
TCRB Tube C	Multiple Dβ + Jβ1/2	1 x 1500 µL tube	10 x 1500 µL tubes
Specimen Control Size Ladder	Multiple Genes	1 x 1500 µL tube	10 x 1500 µL tubes

## Gel Electrophoresis Detection

Heteroduplex analysis is performed to differentiate clonal and non-clonal PCR products. It involves heat denaturation of double-stranded DNA, followed by a snap chilling process to force DNA strands to quickly reanneal. In non-clonal populations, this process causes a majority of the single-stranded DNA to incorrectly bind to non-homologous strands, resulting in secondary structures and reducing the DNA's ability to migrate through a non-denaturing polyacrylamide gel. As a result, polyclonal products are frequently observed as smears at high molecular weights. In clonal populations, after heteroduplex analysis is performed, most denatured single-strand PCR products will reanneal correctly with homologous strands of DNA (reforming homoduplexes), allowing them to easily migrate through the polyacrylamide gel as a single band. Therefore, heteroduplex analysis is key for analyzing PCR products visualized using gel detection methods, as it increases the separation between clonal and polyclonal products.

### TCRB Tube A

Lane 1 = 100% IVS-0004  
Lane 2 = 100% IVS-0009  
Lane 3 = 10% IVS-0009  
Lane 4 = 100% IVS-0000

Valid Size Range = →  
240-285 bp →

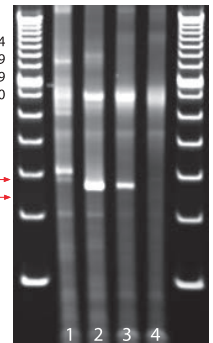

## Capillary Electrophoresis Detection (ABI)

Differential fluorescence detection, such as ABI fluorescence detection, is commonly used to resolve different-sized amplicon products using a capillary electrophoresis instrument. Primers can be conjugated with several different fluorescent dyes (fluorophores), so that they produce different emission spectra upon excitation by a laser in the capillary electrophoresis instrument. In this manner, different fluorescent dyes can correspond to different targeted regions. This detection system results in excellent sensitivity, single nucleotide resolution, differential product detection, and relative quantification. In addition, differential detection allows accurate, reproducible and objective interpretation of primer-specific products. Inter-assay and intra-assay reproducibility in size determination using capillary electrophoresis is approximately 1 to 4 nucleotides.

### TCRB Tube A - 6FAM & HEX

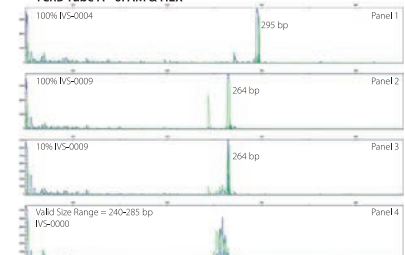

## Ordering Information

Catalog #	Products	Quantity
9-205-0010	IdentiClone <sup>®</sup> TCRB Clonality Assay - Gel Detection	33 reactions
9-205-0020	IdentiClone <sup>®</sup> TCRB Clonality Assay MegaKit - Gel Detection	330 reactions
9-205-0011	IdentiClone <sup>®</sup> TCRB Clonality Assay - ABI Fluorescence Detection	33 reactions
9-205-0021	IdentiClone <sup>®</sup> TCRB Clonality Assay MegaKit - ABI Fluorescence Detection	330 reactions

These are *in vitro* diagnostic products, and are not available for sale or use within North America.

# T-Cell Receptor Gamma Gene Rearrangement Assay 2.0

## Assay Description

The IdentiClone T-Cell Receptor Gamma Gene Rearrangement Assay 2.0 is an *in vitro* diagnostic product intended for PCR-based detection of clonal T-cell receptor gamma chain gene rearrangements in patients with suspect lymphoproliferations.

Specifically, the T-Cell Receptor Gamma Gene Rearrangement Assay 2.0 can be used to identify clonality in suspected lymphoproliferations.

## Summary and Explanation of the Test

Rearrangements of the antigen receptor genes occur during ontogeny in B- and T-lymphocytes. These gene rearrangements generate products that are unique in length and sequence. Polymerase chain reaction (PCR) assays can be used to identify lymphocyte populations derived from a single cell by detecting the unique V-J gene rearrangements present within these antigen receptor loci.

The Invivoscribe designed CE-marked IdentiClone Assays represents an improved approach to PCR-based clonality testing of lymphoproliferative disorders, as it can detect the vast majority of T-cell receptor gamma (*TRG*, formerly known as *TCRG*) gene rearrangements with a single multiplex master mix.

This assay allows for amplification of the *TRG* region with fluorescent labeled primers, yielding products that can be grouped under a single Gaussian distribution when separated by size using capillary electrophoresis. In addition, the product size facilitates increased success when testing FFPE samples. The included analysis algorithm aids in the interpretation of data and identification of significant clonal peaks. Presence or absence of molecular clonality can support the differential diagnosis of reactive lesions and certain B- and T-cell malignancies, provided that the results are interpreted in the context of all available clinical, histological, and immunophenotypic data.

## Performance Characteristics

To assess the performance of the *TCRG* 2.0 Assay, testing was performed on cell lines with known clonal rearrangements followed by testing on previously sequenced clinical samples.

When used in combination with the provided *TCRG* Algorithm worksheet, the assay was capable of detecting DNA from 6 control cell lines (200 ng/μL) diluted into polyclonal tonsil DNA (200 ng/μL) at 5% (v/v).

Furthermore, the performance of the *TCRG* 2.0 Assay was evaluated on clinical samples for which the T-cell receptor gamma gene rearrangement status had been identified by Roche 454 sequencing. For the 7 samples that had been identified as clonal by sequencing, the *TCRG* 2.0 assay had 100% concordance. For the 12 samples that were either negative for a clonal event or were oligoclonal, concordance of the *TCRG* 2.0 assay was 75%. Sample types included peripheral blood, bone marrow, and formalin-fixed, paraffin embedded (FFPE) tissue.

Always interpret the results of molecular clonality tests in the context of clinical, histological and immunophenotypic data.

## Reference

1. Miller JE, Wilson SS, Jaye DJ, and Kronenberg M. *Mol. Diag.* 1999, 4(2):101-117.
2. Armand, Marine et al. *HemaSphere*, 2019;3:3.



This assay was developed by Invivoscribe.

The performance of this assay was reviewed and validated by the EuroClonality/BIOMED-2 Group.<sup>2</sup>

**Figure Legend:** Simple representation of the organization of the T-cell receptor gamma gene on chromosome 7p14. Black arrows represent the relative positions of primers that target the variable region genes and the downstream joining region gene segments that are involved in rearrangements in T-cell lymphomas. The downstream primers are fluorescently labeled through the incorporation of a 6FAM fluorophore. The amplicon products generated from these rearrangements are detected by capillary electrophoresis.

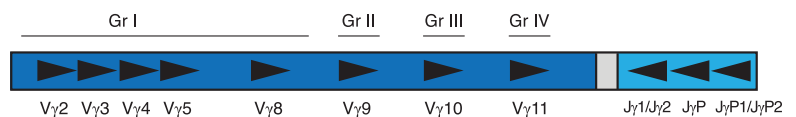

## Reagents

Controls	Concentration	Units in Assay	Units in Assay MegaKit
5% TCRG Positive Control DNA	50 µg/mL	1 x 50 µL tube	5 x 50 µL tube
TCRG Negative Control DNA	50 µg/mL	1 x 50 µL tube	5 x 50 µL tube
Master Mixes	Target	Units in Assay	Units in Assay MegaKit
TCRG - 6FAM	Vy1-Vy11 + Jy1/Jy2, JyP, JyP1/JyP2	1 x 1500 µL tube	10 x 1500 µL tubes
Specimen Control Size Ladder	Multiple Genes	1 x 1500 µL tube	10 x 1500 µL tubes

## Capillary Electrophoresis Detection (ABI)

Fluorescence detection is commonly used to resolve the different sized amplicon products using a capillary electrophoresis instrument. Primers are conjugated with a 6-FAM fluorescent dye (fluorophore), so that they can be detected upon excitation by laser. This detection system results in a high sensitivity, single nucleotide size resolution, and relative quantification. Inter- and intra-assay reproducibility in size determination using capillary electrophoresis is approximately 1 to 4 nucleotides. The data shown were generated using the TCRG-6FAM master mix. Amplified products were run on an ABI 3130 instrument.

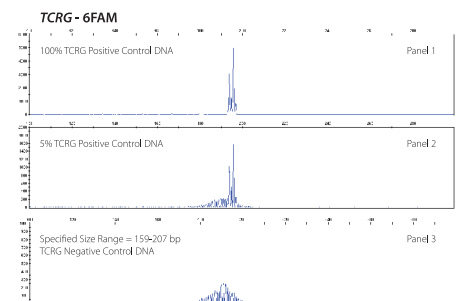

## Ordering Information

Catalog #	Products	Quantity
9-207-0101	IdentiClone® T-Cell Receptor Gamma Gene Rearrangement Assay 2.0 - ABI Fluorescence Detection	33 reactions
9-207-0111	IdentiClone® T-Cell Receptor Gamma Gene Rearrangement Assay MegaKit 2.0 - ABI Fluorescence Detection	330 reactions

These are *in vitro* diagnostic products, and are not available for sale or use within North America.

# TCRG Gene Clonality Assays

## Assay Description

The IdentiClone TCRG Gene Clonality Assays are *in vitro* diagnostic products intended for PCR-based detection of clonal T-cell receptor gamma chain gene rearrangements in patients with suspect lymphoproliferations.

Specifically, the IdentiClone TCRG Gene Clonality Assays can be used to:

- Identify clonality in suspect lymphoproliferations
- Support a differential diagnosis between reactive lesions and T-cell and some immature B-cell malignancies
- Determine lineage involvement in mature lymphoproliferative disorders
- Monitor and evaluate disease recurrence

## Summary and Explanation of the Test

The Invivoscribe CE-marked IdentiClone Assays represent a unique approach to PCR-based clonality testing. These standardized assays were carefully optimized testing positive and negative control samples using multiplex master mixes. Assay development was followed by extensive validation including the testing of more than 400 clinical samples using Revised European/American Lymphoma (REAL) Classification. Testing was done at more than thirty prominent independent testing centers throughout Europe in a collaborative study known as the BIOMED-2 Concerted Action. Results from this BIOMED-2 study appear in *Leukemia*, a leading peer-reviewed journal.<sup>1</sup>

These test kits include three master mixes targeting TRG (formerly known as TCRG) gene rearrangements. TCRG Tube A contains primers that target the Vy1-8 + Vy10 genes and Jy1.1, Jy1.3, Jy2.1, and Jy2.3 genes (also known as JyP1, Jy1, JyP2, and Jy2 respectively). TCRG

Tube B contains primers that target the Vy9 + Vy11 genes and Jy1.1, Jy1.3, Jy2.1, and Jy2.3 genes. The Specimen Control Size Ladder master mix targets multiple genes and generates a series of amplicons of approximately 100, 200, 300, 400, and 600 base pairs to ensure that the quality and quantity of input DNA is adequate to yield a valid result. A single thermal cycler program and similar detection methodologies are used with all of our gene clonality assays. This improves consistency and facilitates cross-training.

## Performance Characteristics

Data from an independent, peer-reviewed study suggests the diagnostic accuracy of selected IdentiClone tests to be 96%. There were no clear false-positive results generated using the IdentiClone tests, and there was a high level of precision. The clinico-histopathological diagnosis correlates well with PCR results in a higher number of patients when compared with Southern Blot (SB) results, as seen below:

PCR/SB concordance:<sup>1</sup>

IGH:	93% sensitivity / 92% specificity
IGK:	90% sensitivity / 90% specificity
IGL:	86% sensitivity / 92% specificity
TRB:	86% sensitivity / 98% specificity
TRG:	89% sensitivity / 94% specificity
TRD:	83% sensitivity / 95% specificity

## Reference

1. JJM van Dongen et al., *Leukemia* 17:2257-2317 (2003).

**Figure Legend:** Simple representation of the organization of the T-cell receptor gamma chain gene on chromosome 7. Black arrows represent the relative positions of primers that target the variable (Vy) regions, and the downstream joining (Jy) gene segments. The amplicon products generated from each of these regions can be differentially detected when fluorescent primer sets are used with capillary electrophoresis instruments that employ differential fluorescence detection.

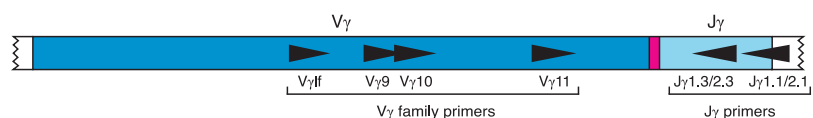

TCRG tube A: Vy1f and Vy10 primers + Jy1.1/2.1 and Jy1.3/2.3

TCRG tube B: Vy9 and Vy11 primers + Jy1.1/2.1 and Jy1.3/2.3



## Reagents

Controls	Concentration	Units in Assay	Units in Assay MegaKit
IVS-0009 Clonal Control DNA	200 µg/mL	1 x 100 µL tube	5 x 100 µL tubes
IVS-0021 Clonal Control DNA	200 µg/mL	1 x 100 µL tube	5 x 100 µL tubes
IVS-0000 Polyclonal Control DNA	200 µg/mL	1 x 100 µL tube	5 x 100 µL tubes
Master Mixes	Target	Units in Assay	Units in Assay MegaKit
TCRG Tube A	Vy1-8 + Vy10 + Jy	1 x 1500 µL tube	10 x 1500 µL tubes
TCRG Tube B	Vy9 + Vy11 + Jy	1 x 1500 µL tube	10 x 1500 µL tubes
Specimen Control Size Ladder	Multiple Genes	1 x 1500 µL tube	10 x 1500 µL tubes

## Gel Electrophoresis Detection

Heteroduplex analysis is performed to differentiate clonal and non-clonal PCR products. It involves heat denaturation of double-stranded DNA, followed by a snap chilling process to force DNA strands to quickly reanneal. In non-clonal populations, this process causes a majority of the single-stranded DNA to incorrectly bind to non-homologous strands, resulting in secondary structures and reducing the DNA's ability to migrate through a non-denaturing polyacrylamide gel. As a result, polyclonal products are frequently observed as smears at high molecular weights. In clonal populations, after heteroduplex analysis is performed, most denatured single-strand PCR products will reanneal correctly with homologous strands of DNA (reforming homoduplexes), allowing them to easily migrate through the polyacrylamide gel as a single band. Therefore, heteroduplex analysis is key for analyzing PCR products visualized using gel detection methods, as it increases the separation between clonal and polyclonal products.

### TCRG Tube A

Lane 1 = 100% IVS-0026  
Lane 2 = 100% IVS-0021  
Lane 3 = 10% IVS-0021  
Lane 4 = 100% IVS-0000

Valid Size Range =  
145-255 bp

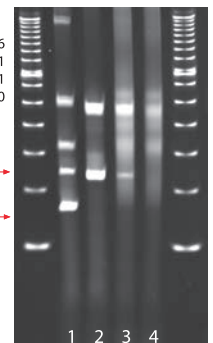

## Capillary Electrophoresis Detection (ABI)

Differential fluorescence detection, such as ABI Fluorescence Detection, is commonly used to resolve different-sized amplicon products using a capillary electrophoresis instrument. Primers can be conjugated with several different fluorescent dyes (fluorophores), so that they produce different emission spectra upon excitation by a laser in the capillary electrophoresis instrument. In this manner, different fluorescent dyes can correspond to different targeted regions. This detection system results in excellent sensitivity, single nucleotide resolution, differential product detection, and relative quantification. In addition, differential detection allows accurate, reproducible and objective interpretation of primer-specific products. Inter-assay and intra-assay reproducibility in size determination using capillary electrophoresis is approximately 1 to 4 nucleotides.

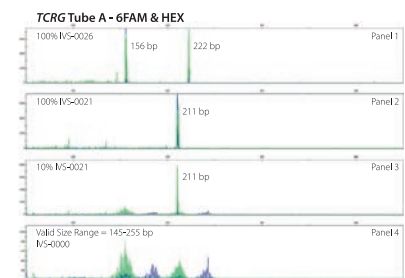

## Ordering Information

Catalog #	Products	Quantity
9-207-0020	IdentiClone <sup>®</sup> TCRG Gene Clonality Assay - Gel Detection	33 reactions
9-207-0040	IdentiClone <sup>®</sup> TCRG Gene Clonality Assay MegaKit - Gel Detection	330 reactions
9-207-0021	IdentiClone <sup>®</sup> TCRG Gene Clonality Assay - ABI Fluorescence Detection	33 reactions
9-207-0041	IdentiClone <sup>®</sup> TCRG Gene Clonality Assay MegaKit - ABI Fluorescence Detection	330 reactions

These are *in vitro* diagnostic products, and are not available for sale or use within North America.

# TCRD Gene Clonality Assays

## Assay Description

The IdentiClone TCRD Gene Clonality Assays are *in vitro* diagnostic products intended for PCR-based detection of clonal T-cell receptor delta chain gene rearrangements in patients with suspect lymphoproliferations.

Specifically, the IdentiClone TCRD Gene Clonality Assays can be used to:

- Identify clonality in suspect lymphoproliferations
- Support a differential diagnosis between reactive lesions and T-cell and some immature B-cell malignancies
- Determine lineage involvement in mature lymphoproliferative disorders
- Monitor and evaluate disease recurrence

## Summary and Explanation of the Test

The Invivoscribe CE-marked IdentiClone Assays represent a unique approach to PCR-based clonality testing. These standardized assays were carefully optimized testing positive and negative control samples using multiplex master mixes. Assay development was followed by extensive validation including the testing of more than 400 clinical samples using Revised European/American Lymphoma (REAL) Classification. Testing was done at more than thirty prominent independent testing centers throughout Europe in a collaborative study known as the BIOMED-2 Concerted Action. Results from this BIOMED-2 study appear in *Leukemia*, a leading peer-reviewed journal.<sup>1</sup>

These test kits include two master mixes. The TCRD tube targets the framework regions within the variable region, the diversity region, and the joining region of the T-cell receptor delta chain locus (*TRD*),

**Figure Legend:** Simplified diagram of a representative rearranged T-cell receptor delta gene showing the approximate placement of the upstream and downstream DNA primers. The numbers of primers and their specificity are listed for the TRD Tube Master Mix tube.

formerly known as *TCRD*). The Specimen Control Size Ladder master mix targets multiple genes and generates a series of amplicons of approximately 100, 200, 300, 400, and 600 base pairs to ensure that the quality and quantity of input DNA is adequate to yield a valid result. A single thermal cycler program and similar detection methodologies are used with all of our gene clonality assays. This improves consistency and facilitates cross-training.

## Performance Characteristics

Data from an independent, peer-reviewed study suggests the diagnostic accuracy of selected IdentiClone tests to be 96%. There were no clear false-positive results generated using the IdentiClone tests, and there was a high level of precision. The clinico-histopathological diagnosis correlates well with PCR results in a higher number of patients when compared with Southern Blot (SB) results, as seen below:

PCR/SB concordance:<sup>1</sup>

<i>IGH</i> :	93% sensitivity / 92% specificity
<i>IGK</i> :	90% sensitivity / 90% specificity
<i>IGL</i> :	86% sensitivity / 92% specificity
<i>TRB</i> :	86% sensitivity / 98% specificity
<i>TRG</i> :	89% sensitivity / 94% specificity
<i>TRD</i> :	83% sensitivity / 95% specificity

## Reference

1. JJM van Dongen et al., *Leukemia* 17:2257-2317 (2003).

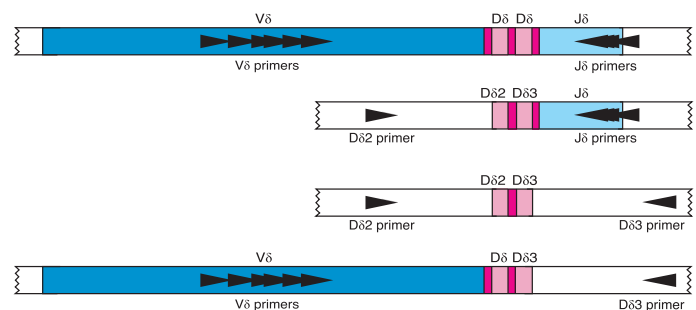

TCRD tube: 6 Vδ and 1 Dδ2 primers + 4 Jδ and 1 Dδ3 primers

## Reagents

Controls	Concentration	Units in Assay	Units in Assay MegaKit
IVS-0021 Clonal Control DNA	200 µg/mL	1 x 100 µL tube	5 x 100 µL tubes
IVS-0000 Polyclonal Control DNA	200 µg/mL	1 x 100 µL tube	5 x 100 µL tubes
Master Mixes	Target	Units in Assay	Units in Assay MegaKit
TCRD Tube	Multiple Vδ + Dδ + Jδ	1 x 1500 µL tube	10 x 1500 µL tubes
Specimen Control Size Ladder	Multiple Genes	1 x 1500 µL tube	10 x 1500 µL tubes

## Gel Electrophoresis Detection

Heteroduplex analysis is performed to differentiate clonal and non-clonal PCR products. It involves heat denaturation of double-stranded DNA, followed by a snap chilling process to force DNA strands to quickly reanneal. In non-clonal populations, this process causes a majority of the single-stranded DNA to incorrectly bind to non-homologous strands, resulting in secondary structures and reducing the DNA's ability to migrate through a non-denaturing polyacrylamide gel. As a result, polyclonal products are frequently observed as smears at high molecular weights. In clonal populations, after heteroduplex analysis is performed, most denatured single-strand PCR products will reanneal correctly with homologous strands of DNA (reforming homoduplexes), allowing them to easily migrate through the polyacrylamide gel as a single band. Therefore, heteroduplex analysis is key for analyzing PCR products visualized using gel detection methods, as it increases the separation between clonal and polyclonal products.

### TCRD Tube

Lane 1 = 100% IVS-0014  
Lane 2 = 100% IVS-0021  
Lane 3 = 10% IVS-0021  
Lane 4 = 100% IVS-0000

Valid Size Range =  
120-280 bp

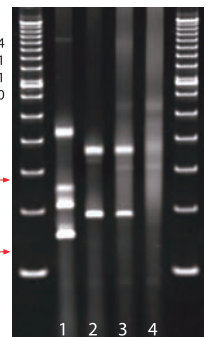

## Capillary Electrophoresis Detection (ABI)

Differential fluorescence detection, such as ABI Fluorescence Detection, is commonly used to resolve different-sized amplicon products using a capillary electrophoresis instrument. Primers can be conjugated with several different fluorescent dyes (fluorophores), so that they produce different emission spectra upon excitation by a laser in the capillary electrophoresis instrument. In this manner, different fluorescent dyes can correspond to different targeted regions. This detection system results in excellent sensitivity, single nucleotide resolution, differential product detection, and relative quantification. In addition, differential detection allows accurate, reproducible and objective interpretation of primer-specific products. Inter-assay and intra-assay reproducibility in size determination using capillary electrophoresis is approximately 1 to 4 nucleotides.

### TCRD Tube - 6FAM & HEX

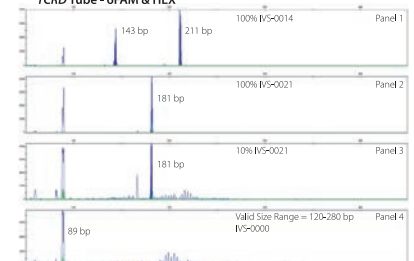

## Ordering Information

Catalog #	Products	Quantity
9-206-0010	IdentiClone <sup>®</sup> TCRD Gene Clonality Assay - Gel Detection	33 reactions
9-206-0020	IdentiClone <sup>®</sup> TCRD Gene Clonality Assay MegaKit - Gel Detection	330 reactions
9-206-0011	IdentiClone <sup>®</sup> TCRD Gene Clonality Assay - ABI Fluorescence Detection	33 reactions
9-206-0021	IdentiClone <sup>®</sup> TCRD Gene Clonality Assay MegaKit - ABI Fluorescence Detection	330 reactions

These are *in vitro* diagnostic products, and are not available for sale or use within North America.

# BCL1/JH Translocation Assay

## Assay Description

The IdentiClone BCL1/JH Translocation Assay is an *in vitro* diagnostic product intended for PCR-based detection of BCL1/JH t(11;14)(q13;q32) gene translocations in patients with suspect lymphoproliferations.

Specifically, the BCL1/JH Translocation Assay can be used to:

- Identify BCL1/JH gene translocations highly suggestive of mantle cell lymphoma (MCL)
- Distinguish mantle cell lymphoma from other neoplastic or benign B-cell proliferations
- Monitor and evaluate disease recurrence

## Summary and Explanation of the Test

The Invivoscribe CE-marked IdentiClone assays represent a unique approach to PCR-based clonality testing. These standardized assays were carefully optimized testing positive and negative control samples using multiplex master mixes. Assay development was followed by extensive validation including the testing of more than 400 clinical samples using Revised European/American Lymphoma (REAL) Classification. Testing was done at more than thirty prominent independent testing centers throughout Europe in a collaborative study known as the BIOMED-2 Concerted Action. Results from this BIOMED-2 study appear in *Leukemia*, a leading peer-reviewed journal.<sup>1</sup>

These test kits include includes two master mixes. The BCL1/JH Tube targets the major translocation cluster (MTC) of the IGH-CCND1 locus and the joining region of the immunoglobulin heavy chain locus. The Specimen Control Size Ladder master mix targets multiple genes and generates a series of amplicons of approximately 100, 200, 300, 400, and 600 base pairs to ensure that the quality and quantity of input DNA is adequate to yield a valid result. A single thermal cycler program and similar detection methodologies are used with many of our assays. This improves consistency and facilitates cross-training.

**Figure Legend:** Schematic diagram of the IGH-CCND1 t(11;14) translocation showing the cyclin D1 (CCND1) gene on the left and the Ig heavy chain (IGH) gene on the right. Shown are the relative positions and orientations for the BCL1/MTC primer and the JH primer, which are included in the BCL1/JH Master Mix tube.

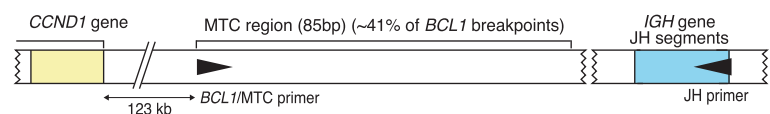

t(11;14) tube: 1 BCL1 MTC primer + 1 JH primer

## Performance Characteristics

The assay analytical performance was evaluated by testing spiked Mantle Cell Lymphoma (MCL) IGH-CCND1 positive cell-line DNA into tonsil DNA at six different dilutions. The Limit of Detection (LoD) was observed at 0.1% DNA dilution. To evaluate within-laboratory precision, complete agreement of results was observed across four runs executed by two operators over two days.

Testing conducted across three laboratories using 25 samples from cases of MCL with IGH-CCND1 translocations and 18 negative samples, showed 100% concordance of positive samples (25 of 25 samples) using fluorescence detection, and 88% (22 of 25 samples) using gel detection. For the negative samples, the concordance was 100% using both gel detection (18 of 18 samples) and fluorescence detection (18 of 18 samples) formats. Specificity for both formats was 100% and sensitivity was determined to be between 10<sup>-3</sup> and 10<sup>-4</sup>. The sensitivity is sufficiently high for the detection of the IGH-CCND1 breakpoint in diagnostic material. However, only 40–50% of the t(11;14) breakpoints in MCL will be detected by PCR alone and additional detection method tools are recommended for diagnosis of breakpoints that do not fall within the major translocation cluster region.

## Reference

1. JJM van Dongen et al., *Leukemia* 17:2257–2317 (2003).

## Reagents

Controls	Concentration	Units in Assay	Units in Assay MegaKit
IVS-0010 Clonal Control DNA	200 µg/mL	1 x 100 µL tube	5 x 100 µL tubes
IVS-0000 Polyclonal Control DNA	200 µg/mL	1 x 100 µL tube	5 x 100 µL tubes
Master Mixes	Target	Units in Assay	Units in Assay MegaKit
<i>BCL1/JH</i> Tube - Unlabeled	MTC of <i>BCL1 + IGH/JH</i>	1 x 1500 µL tube	10 x 1500 µL tubes
Specimen Control Size Ladder - Unlabeled	Multiple Genes	1 x 1500 µL tube	10 x 1500 µL tubes

## Gel Electrophoresis Detection

Gel electrophoresis, such as agarose gel electrophoresis, is commonly used to resolve different amplicon products based on their size, charge, and conformation. Since DNA is negatively charged, when an electrical potential (voltage) is applied across the gel containing PCR products, the electrical field causes the amplicons to migrate through the gel. Smaller DNA fragments are able to easily migrate through the gel matrix, whereas larger DNA fragments migrate more slowly. This causes a separation of the amplicon products based on size. Ethidium bromide or other DNA intercalating dyes can then be used to stain and detect these products in the gel. The use of a DNA ladder allows the relative size of amplicons to be determined.

### *BCL1/JH* Tube

Lane 1 = 100% IVS-0010  
 Lane 2 = 10% IVS-0010  
 Lane 3 = 1% IVS-0010  
 Lane 4 = 0.1% IVS-0010  
 Lane 5 = 100% IVS-0000

Valid Size Range =  
 150-2000 bp

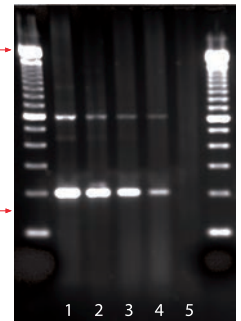

Ordering Information		
Catalog #	Products	Quantity
9-308-0010	IdentiClone <sup>®</sup> <i>BCL1/JH</i> Translocation Assay - Gel Detection	33 reactions
9-308-0020	IdentiClone <sup>®</sup> <i>BCL1/JH</i> Translocation Assay MegaKit - Gel Detection	330 reactions

These are *in vitro* diagnostic products, and are not available for sale or use within North America.

# BCL2/JH Translocation Assay

## Assay Description

The IdentiClone BCL2/JH Translocation Assay is an *in vitro* diagnostic product intended for PCR-based detection of IGH-BCL2 t(14;18) gene translocations in patients with suspect lymphoproliferations.

Specifically, the BCL2/JH Translocation Assay can be used to:

- Distinguish lymphoma from benign lymphoid hyperplasia
- Distinguish follicular lymphoma (FL) from other B-cell lymphomas that may have a similar appearance
- Monitor and evaluate disease recurrence

## Summary and Explanation of the Test

The Invivoscribe CE-marked IdentiClone Assays represent a unique approach to PCR-based clonality testing. These standardized assays were carefully optimized testing positive and negative control samples using multiplex master mixes. Assay development was followed by extensive validation including the testing of more than 400 clinical samples using Revised European/American Lymphoma (REAL) Classification. Testing was done at more than thirty prominent independent testing centers throughout Europe in a collaborative study known as the BIOMED-2 Concerted Action. Results from this BIOMED-2 study appear in *Leukemia*, a leading peer-reviewed journal.<sup>1</sup>

These test kits include four master mixes. The BCL2/JH Translocation master mixes (BCL2/JH Tubes A, B, and C) target the joining (J) region of the immunoglobulin heavy chain (IGH) gene and distinct regions of the BCL2 gene. These master mixes are used to detect major breakpoint region (MBR) and minor cluster region (mcr) of the IGH-BCL2 t(14;18)(q32;q21) translocations. The Specimen Control Size

**Figure Legend:** Schematic diagram of the IGH-BCL2 t(14;18) translocation showing the BCL2 gene on the left and the Ig heavy chain (IGH) gene on the right. Shown are the relative positions and orientations for the major breakpoint region (MBR) primers, the minor cluster region (mcr) primers, and the JH primer, which are included in the 3 BCL2/JH master mix tubes.

Ladder master mix targets multiple genes and generates a series of amplicons of approximately 100, 200, 300, 400, and 600 base pairs to ensure that the quality and quantity of input DNA is adequate to yield a valid result. A single thermal cycler program and similar detection methodologies are used with many of our assays. This improves consistency and facilitates cross-training.

## Performance Characteristics

The initial evaluation of this assay was performed in three laboratories on DNA derived from 124 cases of follicular cell lymphoma (FCL) known to carry the t(14;18) translocation. 109 cases were identified with the IGH-BCL2 fusion gene (88%) using this PCR assay. The final testing and evaluation was done on samples in 11 independent laboratories<sup>1</sup>. False-positive results (0.4%) were only seen in 12 of 3036 analyses.

This IdentiClone BCL2/JH Translocation Assay was found to be more sensitive than Southern blot analysis. Sensitivity differed slightly between the master mixes. However, overall sensitivity for the assay was determined to be between 1 positive cell in 10<sup>2</sup> normal cells and 1 positive cell in 10<sup>3</sup> normal cells.

In conclusion, we have designed and evaluated the performance characteristics of a robust three tube multiplex PCR assay in order to maximize the detection of the t(14;18) breakpoint. This strategy is capable of amplifying across the breakpoint region in the majority of cases of follicular lymphoma with a cytogenetically defined translocation.

## Reference

1. JJM van Dongen et al., *Leukemia* 17:2257 - 2317 (2003).

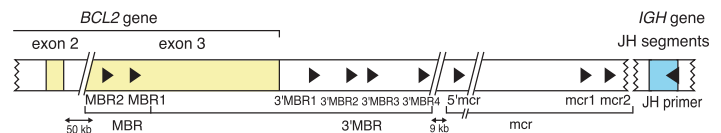

t(14;18) tube A: 2 BCL2 MBR primers + 1 JH primer

t(14;18) tube B: 4 BCL2 3'MBR primers + 1 JH primer

t(14;18) tube C: 3 BCL2 mcr primers + 1 JH primer

## Reagents

Controls	Concentration	Units in Assay	Units in Assay MegaKit
IVS-0030 Clonal Control DNA	100 µL @ 200 µg/mL	1 x 100 µL tube	5 x 100 µL tubes
IVS-P002 Clonal Control DNA	100 µL @ 1600 pg/mL	1 x 100 µL tube	5 x 100 µL tubes
IVS-0031 Clonal Control DNA	100 µL @ 200 µg/mL	1 x 100 µL tube	5 x 100 µL tubes
IVS-0000 Polyclonal Control DNA	100 µL @ 200 µg/mL	1 x 100 µL tube	5 x 100 µL tubes
Master Mixes	Target	Units in Assay	Units in Assay MegaKit
BCL2/JH Tube A - Unlabeled	BCL2 MBR + IGH JH	1 x 1500 µL tube	10 x 1500 µL tubes
BCL2/JH Tube B - Unlabeled	BCL2 3' MBR + IGH JH	1 x 1500 µL tube	10 x 1500 µL tubes
BCL2/JH Tube C - Unlabeled	BCL2 mcr + IGH JH	1 x 1500 µL tube	10 x 1500 µL tubes
Specimen Control Size Ladder - Unlabeled	Multiple Genes	1 x 1500 µL tube	10 x 1500 µL tubes

## Gel Electrophoresis Detection

Gel electrophoresis, such as agarose gel electrophoresis, is commonly used to resolve different amplicon products based on their size, charge, and conformation. Since DNA is negatively charged, when an electrical potential (voltage) is applied across the gel containing PCR products, the electrical field causes the amplicons to migrate through the gel. Smaller DNA fragments are able to easily migrate through the gel matrix, whereas larger DNA fragments migrate more slowly. This causes a separation of the amplicon products based on size. Ethidium bromide or other DNA intercalating dyes can then be used to stain and detect these products in the gel.

### BCL2/JH Tube A

Lane 1 = 100% IVS-0007  
Lane 2 = 100% IVS-0030  
Lane 3 = 1% IVS-0030  
Lane 4 = 100% IVS-0000

Valid Size Range =  
100-2500 bp

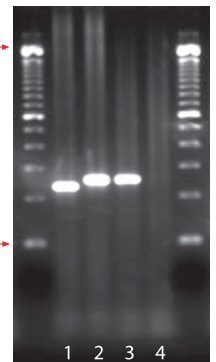

## Ordering Information

Catalog #	Products	Quantity
9-309-0020	IdentiClone <sup>®</sup> BCL2/JH Translocation Assay - Gel Detection	33 reactions
9-309-0040	IdentiClone <sup>®</sup> BCL2/JH Translocation Assay MegaKit - Gel Detection	330 reactions

These are *in vitro* diagnostic products, and are not available for sale or use within North America.

# LeukoStrat<sup>®</sup>

## Gel and Capillary Assays and Assays

82/ *FLT3* Mutation Assay  
Gel Detection

88 / LeukoStrat CDx *FLT3* Mutation  
Assay - AUS

84/ *FLT3* Mutation Assay 2.0  
ABI Fluorescence Detection

90 / LeukoStrat CDx *FLT3* Mutation  
Assay - Japan

86/ LeukoStrat CDx *FLT3* Mutation  
Assay (CE-marked)

### WARRANTY AND LIABILITY

Invivoscribe, Inc. (Invivoscribe<sup>®</sup>) is committed to providing the highest quality products. Invivoscribe<sup>®</sup> warrants that the products meet or exceed the performance standards described in the Instructions For Use, as to products with such an insert. If a product is covered by product specifications and does not perform as specified, our policy is to replace the product or credit the full purchase price. No other warranties of any kind, expressed or implied, are provided by Invivoscribe<sup>®</sup>. Invivoscribe<sup>®</sup> liability shall not exceed the purchase price of the product. Invivoscribe<sup>®</sup> shall have no liability for direct, indirect, consequential or incidental damages arising from the use, results of use, or inability to use its products; product efficacy under purchaser controlled conditions in purchaser's laboratory must be established and continually monitored through purchaser defined and controlled processes including but not limited to testing of positive, negative, and blank controls every time a sample is tested. Ordering, acceptance, and use of product constitutes purchaser acceptance of sole responsibility for assuring product efficacy and purchaser agreement to the limitation of liability set forth in this paragraph.

NOTICE: The products in the section that follows are *in vitro* diagnostic products and are not available for sale or use within North America.

These products require nucleic acid amplification methods such as Polymerase Chain Reaction (PCR). No license under these patents to use amplification processes or enzymes is conveyed expressly or by implication to the purchaser by the purchase of these products.

LeukoStrat<sup>®</sup> is a registered trademark of Invivoscribe<sup>®</sup>.



# LeukoStrat<sup>®</sup>

LeukoStrat Assay kits are *in vitro* diagnostic products.\*

These assay kits are intended for PCR-based detection of *FLT3* activating mutations in patients with acute myelogenous leukemia (AML) using gel or capillary electrophoresis methods.

These tests include Instructions For Use (IFUs) with interpretation guidelines describing the use of the kits' master mixes and controls. Master mixes are composed of a buffered magnesium chloride solution, deoxynucleotides, and primers targeting the gene segments of interest. These assay master mixes are complete other than Taq DNA polymerase.

In the Japan marketed IVD product, Tag DNA Polymerase and EcoRV Enzyme are further included in the LeukoStrat Assay Kit.

These assays are available in regular (33 reactions) and in MegaKit formats (330 reactions), with exception of the LeukoStrat<sup>®</sup> CDx *FLT3* Mutation Assay, which is only available in regular format.

For more information, please visit [www.invivoscribe.com](http://www.invivoscribe.com)

\*NOTICE: LeukoStrat Assays are *in vitro* diagnostic products and are not available for sale or use within North America. For more information regarding the research use only reagents, please see the Gel & Capillary Research Use Only Assays section.

## FLT3 Mutation Assay - Gel Detection

### Assay Description

The LeukoStrat® FLT3 Mutation Assay is an *in vitro* diagnostic product intended for PCR-based detection of FLT3 activating mutations in patients with acute myelogenous leukemia (AML).

Specifically, the FLT3 Mutation Assay can be used to:

- Identify internal tandem duplications (ITD) in the FLT3 gene
- Identify tyrosine kinase domain (TKD) mutations in the FLT3 gene

### Summary and Explanation of the Test

AML in general has a poor prognosis. Assessment of the mutation status of the FLT3 (fms related tyrosine kinase 3) receptor gene in karyotype normal AML is the most important prognostic indicator of disease outcome, which is often substantial, as many studies in AML have shown that the presence of FLT3 activating mutations portends a poor prognosis.<sup>1,2</sup> For this reason, FLT3 activation mutation testing is required to stratify disease and determine appropriate treatment options. This LeukoStrat PCR assay targets regions of the FLT3 gene to identify ITD mutations and TKD mutations, such as the D835 and I836 mutations.

This assay cannot reliably detect FLT3 mutations comprising less than 5% of the total cell population. It should be emphasized that the results of molecular mutation tests should always be interpreted in the context of clinical, histological and immunophenotypic data.

This test kit includes 3 master mixes. (1) FLT3 ITD Master mix tests for internal tandem duplication mutations. (2) FLT3 D835 Master Mix tests for TKD region mutations. (3) The Specimen Control Size Ladder master mix targets multiple genes and generates a series of amplicons of approximately 100, 200, 300, 400, and 600 basepairs to ensure that the quality and quantity of input DNA is adequate to yield a valid result.

### Performance Characteristics

This LeukoStrat FLT3 Mutation Assay offers a rapid and reliable method for detecting FLT3 mutations. This is shown by a validation performed by the Laboratory for Personalized Molecular Medicine (LabPMM).

	Concordance with three independent labs
ITD	100% sensitivity / 100% specificity
TKD	100% sensitivity / 100% specificity

LabPMM tested 57 blinded patient samples obtained from three independent institutions. The institutions determined that 13 of the samples were FLT3 ITD positive, 33 were FLT3 ITD negative, 6 were FLT3 TKD positive, and 50 were FLT3 TKD negative. In addition 10 positive blinded spiked samples and 10 negative samples were used for the validation of FLT3 TKD. The LeukoStrat FLT3 Mutation Assay showed a sensitivity and specificity of 100% with both master mixes. The analytical sensitivity of both master mixes was determined to be 5 positive cells out of 100 total cells.

### Reference

1. Murphy KM et al., A Clinical PCR/Capillary Electrophoresis Assay for the Detection of Internal Tandem Duplication and Point Mutation of the FLT3 Gene. *J. Mol. Diag.* 5:96-102 (2003).
2. Yamamoto, Y., et al., Activating mutation of D835 within the activation loop of FLT3 in human hematologic malignancies. *Blood*, 97(8):2434-9 (2001).

## Reagents

Controls	Concentration	Units in 33 Reaction Assay	Units in 330 Reaction Assay
IVS-0050 Clonal Control DNA	200 µg/mL	1 x 100 µL tube	5 x 100 µL tubes
IVS-P004 Clonal Control DNA	171 pg/mL	1 x 100 µL tube	5 x 100 µL tubes
IVS-0000 Polyclonal Control DNA	200 µg/mL	1 x 100 µL tube	5 x 100 µL tubes
Master Mixes	Target	Units in 33 Reaction Assay	Units in 330 Assay MegaKit
FLT3 ITD Master Mix - Unlabeled	FLT3 ITD	1 x 1500 µL tube	10 x 1500 µL tubes
FLT3 ITD Master Mix - Unlabeled	FLT3 TKD	1 x 1500 µL tube	10 x 1500 µL tubes
Specimen Control Size Ladder	Multiple Genes	1 x 1500 µL tube	10 x 1500 µL tubes

## Gel Electrophoresis Detection

Agarose gel electrophoresis is used to resolve the different amplicon products based on their size, charge, and conformation. Since DNA is negatively charged, when an electrical potential (voltage) is applied across the gel containing PCR products, the electrical field causes the amplicons to migrate through the gel. Smaller DNA fragments are able to easily migrate through the gel matrix, whereas larger DNA fragments migrate more slowly. This causes a separation of the amplicon products based on size. Ethidium bromide or other DNA intercalating dyes can then be used to stain and detect these products in the gel.

**FLT3 ITD Master Mix**  
 Lane 1 = 100% IVS-0050  
 Lane 2 = 10% IVS-0050  
 Lane 3 = 100% IVS-0000

Mutant: 360 bp →  
 Wild Type: 330 bp →

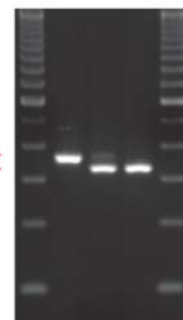

## Ordering Information

Catalog #	Products	Quantity
9-412-0010	LeukoStrat <sup>®</sup> FLT3 Mutation Assay - Gel Detection	33 reactions
9-412-0020	LeukoStrat <sup>®</sup> FLT3 Mutation Assay MegaKit - Gel Detection	330 reactions

## FLT3 Mutation Assay 2.0 – ABI Fluorescence Detection

### Assay Description

The LeukoStrat<sup>®</sup> FLT3 Mutation Assay 2.0 is an *in vitro* diagnostic product intended for PCR-based detection of FLT3 activating mutations in patients with acute myelogenous leukemia (AML).

Specifically, the FLT3 Mutation Assay 2.0 can be used to:

- Identify internal tandem duplications (ITD) in the FLT3 gene
- Identify tyrosine kinase domain (TKD) mutations in the FLT3 gene

### Summary and Explanation of the Test

AML in general has a poor prognosis.<sup>1,2</sup> Assessment of the mutation status of the FLT3 (fms related tyrosine kinase 3) receptor gene is the most important prognostic indicator of disease outcome, occurring in approximately 30% of patients at the time of diagnosis.<sup>3</sup> For this reason, testing for FLT3 activating mutations is required for the stratification of disease and determination of appropriate treatment options. The LeukoStrat FLT3 Mutation Assay 2.0 is a PCR-based method that identifies ITD and TKD mutations. This test kit includes 2 master mixes: the FLT3-ITD Master Mix for the detection of ITD mutations and FLT3-D835 Master Mix for the detection of TKD region mutations (such as the D835 and I836 mutations).

### Performance Characteristics

The LeukoStrat FLT3 Mutation Assay 2.0 is a rapid and reliable method for the detection of FLT3 mutations, as evidenced by comparison with Roche<sup>®</sup> 454 sequencing.

The FLT3 Mutation Assay 2.0 is capable of detecting FLT3-ITD and TKD mutations with excellent concordance (Table 1 and 2) and has high reliability when multiple standard laboratory variables are considered, including multiple operators, reagent lots, different ABI 3500xL instruments, and nonconsecutive testing days.

Table 1. FLT3 ITD Percent Agreement with 454 Sequencing

Percent Agreement		Discordance #	Concordance #	*95% LL
Negative PA	100%	0	119	96.9%
Positive PA	98.0%	4	200	95.1%

\*95% of results would be expected to agree with sequencing at a rate greater than or equal to the lower limit (LL).

Table 2. FLT3 TKD Percent Agreement with 454 Sequencing

Percent Agreement		Discordance #	Concordance #	*95% LL
Negative PA	100%	0	137	96.9%
Positive PA	100%	0	240	98.5%

\*95% of results would be expected to agree with sequencing at a rate greater than or equal to the lower limit (LL).

### Reference

1. Murphy KM et al., A Clinical PCR/Capillary Electrophoresis Assay for the Detection of Internal Tandem Duplication and Point Mutation of the FLT3 Gene. *J. Mol. Diag.* 5:96-102 (2003).
2. Yamamoto, Y., et al., Activating mutation of D835 within the activation loop of FLT3 in human hematologic malignancies. *Blood*, 97(8):2434-9 (2001).
3. Acute Myeloid Leukemia, Clinical Practice Guidelines in Oncology, National Comprehensive Cancer Network (v.2.2014)

# LeukoStrat®

FLT3 Mutation Assay 2.0  
ABI Fluorescence Detection

Gel and Capillary CE IVD Assays and IVD Assays

## Reagents

Controls	Concentration	Units in Assay	Units in MegaKit
FLT3 ITD Positive Control	50 µg/mL	1 x 100 µL tube	5 x 100 µL tubes
FLT3 D835 Positive Control	50 µg/mL	1 x 100 µL tube	5 x 100 µL tubes
FLT3 Negative Control	50 µg/mL	1 x 100 µL tube	5 x 100 µL tubes
Master Mixes	Target	Units in Assay	Units in MegaKit
FLT3 ITD Master Mix – 6FAM & HEX	FLT3 ITD	1 x 1500 µL tube	10 x 1500 µL tubes
FLT3 D835 Master Mix – 6FAM	FLT3 TKD	1 x 1500 µL tube	10 x 1500 µL tubes

## Capillary Electrophoresis Detection (ABI)

Differential fluorescence detection, such as ABI fluorescence detection, is commonly used to resolve different-sized amplicon products using a capillary electrophoresis instrument. Primers can be conjugated with different fluorescent dyes (fluorophores), so that they produce different emission spectra upon excitation by a laser in the capillary electrophoresis instrument. In this manner, different fluorescent dyes can correspond to different targeted regions. This detection system results in high sensitivity, single nucleotide resolution, differential product detection, and relative quantification. In addition, differential detection allows accurate, reproducible and objective interpretation of primer-specific products. Inter-assay and intra-assay reproducibility in size determination using capillary electrophoresis is approximately 1 to 4 nucleotides.

The data shown was generated using the master mixes indicated. Amplified products were run on an ABI 3500xL instrument.

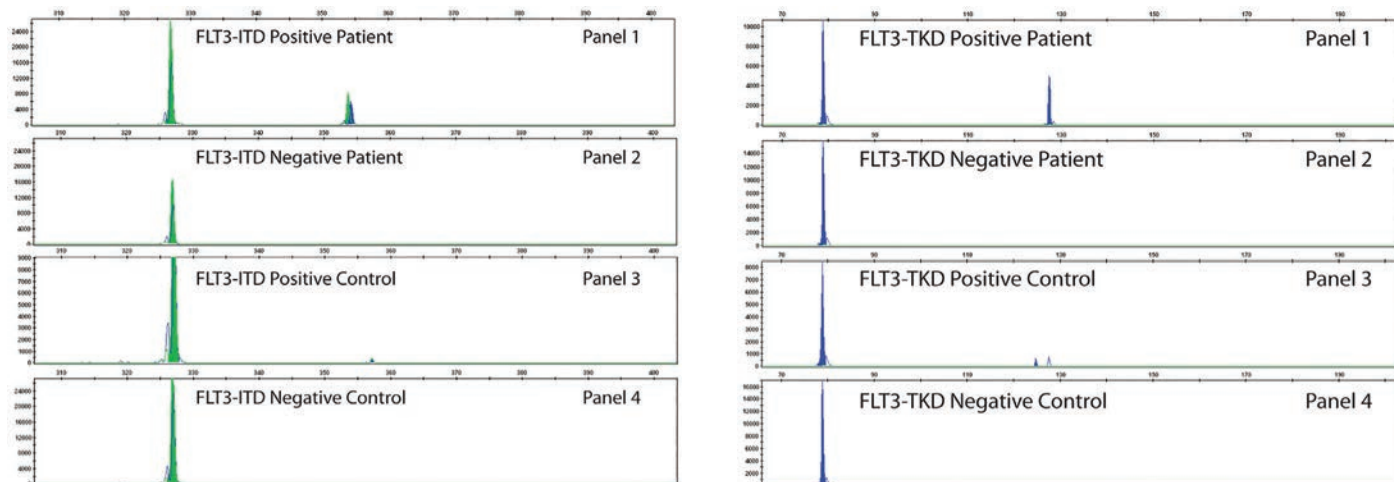

## Ordering Information

Catalog #	Products	Quantity
9-412-0091	LeukoStrat® FLT3 Mutation Assay 2.0 – ABI Fluorescence Detection	33 reactions
9-412-0101	LeukoStrat® FLT3 Mutation Assay 2.0 MegaKit – ABI Fluorescence Detection	330 reactions

These are *in vitro* diagnostic products, and are not available for sale or use within North America.

## CDx *FLT3* Mutation Assay (CE-marked)

The only internationally standardized CE-IVD assay for *FLT3* Signal Ratio mutation analysis for assessment of acute myeloid leukemia (AML) patients eligible for treatment with RYDAPT<sup>®</sup> (midostaurin) or XOSPATA<sup>®</sup> (gilteritinib fumarate).

### Intended Use

The LeukoStrat CDx *FLT3* Mutation Assay is a PCR-based *in vitro* diagnostic test designed to detect internal tandem duplications (ITD) and tyrosine kinase domain (TKD) mutations D835 and I836 in the *FLT3* gene in genomic DNA extracted from mononuclear cells obtained from peripheral blood or bone marrow aspirates of patients diagnosed with acute myelogenous leukemia (AML).

In regions where midostaurin is available, the LeukoStrat CDx *FLT3* Mutation Assay is used as an aid in the assessment of patients with AML for whom RYDAPT<sup>®</sup> (midostaurin) treatment is being considered.

In regions where gilteritinib fumarate is available, the LeukoStrat CDx *FLT3* Mutation Assay is used as an aid in the assessment of patients with AML for whom XOSPATA<sup>®</sup> (gilteritinib fumarate) treatment is being considered.

### Summary and Explanation of the Test

AML in general has a poor prognosis. Assessment of the mutation status of the *FLT3* (fms related tyrosine kinase 3) receptor gene in karyotype normal AML is the most important prognostic indicator of disease outcome, which is often substantial, as many studies in AML have shown that the presence of *FLT3* activating mutations portends a poor prognosis.<sup>1,2</sup> The LeukoStrat CDx *FLT3* Mutation Assay targets regions of the *FLT3* gene to identify ITD mutations and TKD mutations, such as the D835 and I836 mutations, and has been validated in an international clinical trial.

The LeukoStrat CDx *FLT3* Mutation Assay includes reagents, equipment, software and procedures for isolating mononuclear cells and extracting DNA from patient specimens to determine if *FLT3* mutations are present.

DNA is amplified via PCR and the amplicons are detected via capillary electrophoresis. *FLT3* mutation status is determined by the LeukoStrat CDx *FLT3* Software. A *FLT3* ITD and/or TKD mutation is reported as Positive if the mutant:wild-type signal ratio meets or exceeds the clinical cutoff of 0.05.

### Method Description

#### ITD Mutations of *FLT3*

The LeukoStrat CDx *FLT3* Mutation Assay uses fluorescently labeled primers that are in the JM region. Wild-type *FLT3* alleles will amplify and produce a product at 327±1 bp as measured by this assay, while alleles that contain ITD mutations will produce a product that exceeds 330±1 bp (please see Figure, right).

#### TKD Mutations of *FLT3*

The LeukoStrat CDx *FLT3* Mutation Assay uses primers that lie on either side of the TKD region. The *FLT3* target region is amplified using PCR and then an EcoRV restriction digest is performed. Wild-type alleles of the *FLT3* gene yield digestion products of 79±1 bp whereas mutant alleles yield products of 125±1 bp or 127±1 bp from the original undigested amplicon product of 145±1 bp or 147±1 bp, as measured by this assay (please see Figure, right).

### Reference

1. Murphy KM et al., A Clinical PCR/Capillary Electrophoresis Assay for the Detection of Internal Tandem Duplication and Point Mutation of the *FLT3* Gene. *J. Mol. Diag.* 5:96-102 (2003).
2. Yamamoto, Y., et al., Activating mutation of D835 within the activation loop of *FLT3* in human hematologic malignancies. *Blood*, 97(8):2434-9 (2001).

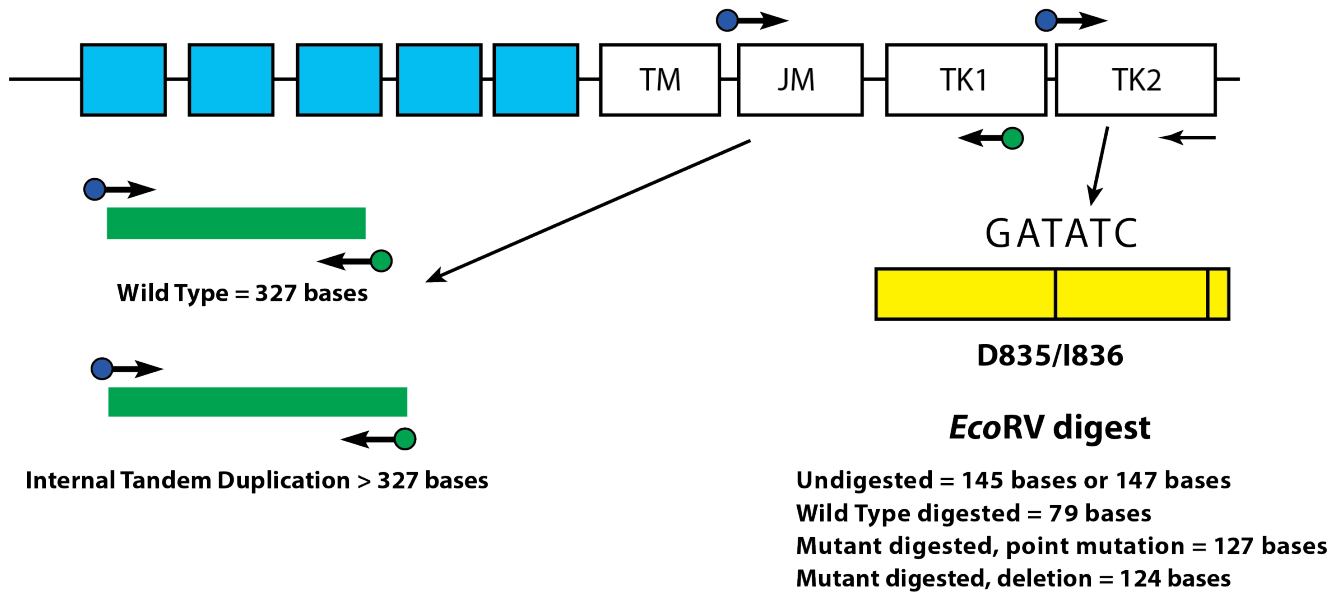

Depicted is a representation of the *FLT3* juxtamembrane (JM) region (TM = transmembrane) and the activating loop of the tyrosine kinase (TK) domain. Black arrows represent the relative positions of primers that target in and around the JM region for ITD or the activating loop of the kinase domain for TKD. Colored dots represent fluorophores on labeled primers. The yellow box has vertical black lines that represent the position of the *EcoRV* restriction digest sites.

## Reagents

Controls	Units in Assay
<i>FLT3</i> Extraction Control	1 x 1800 µL tube
<i>FLT3</i> ITD Master Mix	1 x 1500 µL tube
<i>FLT3</i> TKD Master Mix	1 x 1500 µL tube
<i>FLT3</i> ITD Positive Control	1 x 100 µL tube
<i>FLT3</i> TKD Positive Control	1 x 100 µL tube
<i>FLT3</i> No Template Control	1 x 200 µL tube

All reagents should be stored at -15 to -30 degrees C.

## Ordering Information

Catalog #	Products	Quantity
K-412-0291	LeukoStrat <sup>®</sup> CDx <i>FLT3</i> Mutation Assay	33 reactions
K-412-0281	LeukoStrat <sup>®</sup> CDx <i>FLT3</i> Mutation Assay Software	1 CD complimentary with purchase

## CDx *FLT3* Mutation Assay – AUS

The only internationally standardized IVD assay for *FLT3* Signal Ratio mutation analysis for selection of acute myeloid leukemia (AML) patients eligible for treatment with midostaurin.

### Intended Use

The LeukoStrat<sup>®</sup> CDx *FLT3* Mutation Assay is a PCR-based in vitro diagnostic test designed to detect internal tandem duplications (ITD) and tyrosine kinase domain (TKD) mutations D835 and I836 in the *FLT3* gene in genomic DNA extracted from mononuclear cells obtained from peripheral blood or bone marrow aspirates of patients diagnosed with acute myelogenous leukemia (AML).

In regions where midostaurin is available, the LeukoStrat<sup>®</sup> CDx *FLT3* Mutation Assay is used as an aid in the selection of patients with AML for whom midostaurin treatment is being considered.

### Summary and Explanation of the Test

AML in general has a poor prognosis. Assessment of the mutation status of the *FLT3* (fms related tyrosine kinase 3) receptor gene in karyotype normal AML is the most important prognostic indicator of disease outcome, which is often substantial, as many studies in AML have shown that the presence of *FLT3* activating mutations portends a poor prognosis.<sup>1,2</sup> The LeukoStrat CDx *FLT3* Mutation Assay targets regions of the *FLT3* gene to identify ITD mutations and TKD mutations, such as the D835 and I836 mutations, and has been validated in an international clinical trial.

The LeukoStrat CDx *FLT3* Mutation Assay includes reagents, equipment, software and procedures for isolating mononuclear cells and extracting DNA from patient specimens to determine if *FLT3* mutations are present. DNA is amplified via PCR and the amplicons are detected via capillary electrophoresis. *FLT3* mutation status is determined by the LeukoStrat CDx *FLT3* Software. A *FLT3* ITD and/or TKD mutation is reported as Positive if the mutant:wild-type signal ratio meets or exceeds the clinical cutoff of 0.05.

### Method Description

#### ITD Mutations of *FLT3*

The LeukoStrat CDx *FLT3* Mutation Assay uses fluorescently labeled primers that are in the JM region. Wild-type *FLT3* alleles will amplify and produce a product at 327±1 bp as measured by this assay, while alleles that contain ITD mutations will produce a product that exceeds 330±1 bp (please see Figure, right).

#### TKD Mutations of *FLT3*

The LeukoStrat CDx *FLT3* Mutation Assay uses primers that lie on either side of the TKD region. The *FLT3* target region is amplified using PCR and then an EcoRV restriction digest is performed. Wild-type alleles of the *FLT3* gene yield digestion products of 79±1 bp whereas mutant alleles yield products of 125±1 bp or 127±1 bp from the original undigested amplicon product of 145±1 bp or 147±1 bp, as measured by this assay (please see Figure, right).

### Reference

1. Murphy KM et al., A Clinical PCR/Capillary Electrophoresis Assay for the Detection of Internal Tandem Duplication and Point Mutation of the *FLT3* Gene. *J. Mol. Diag.* 5:96-102 (2003).
2. Yamamoto, Y., et al., Activating mutation of D835 within the activation loop of *FLT3* in human hematologic malignancies. *Blood*, 97(8):2434-9 (2001).



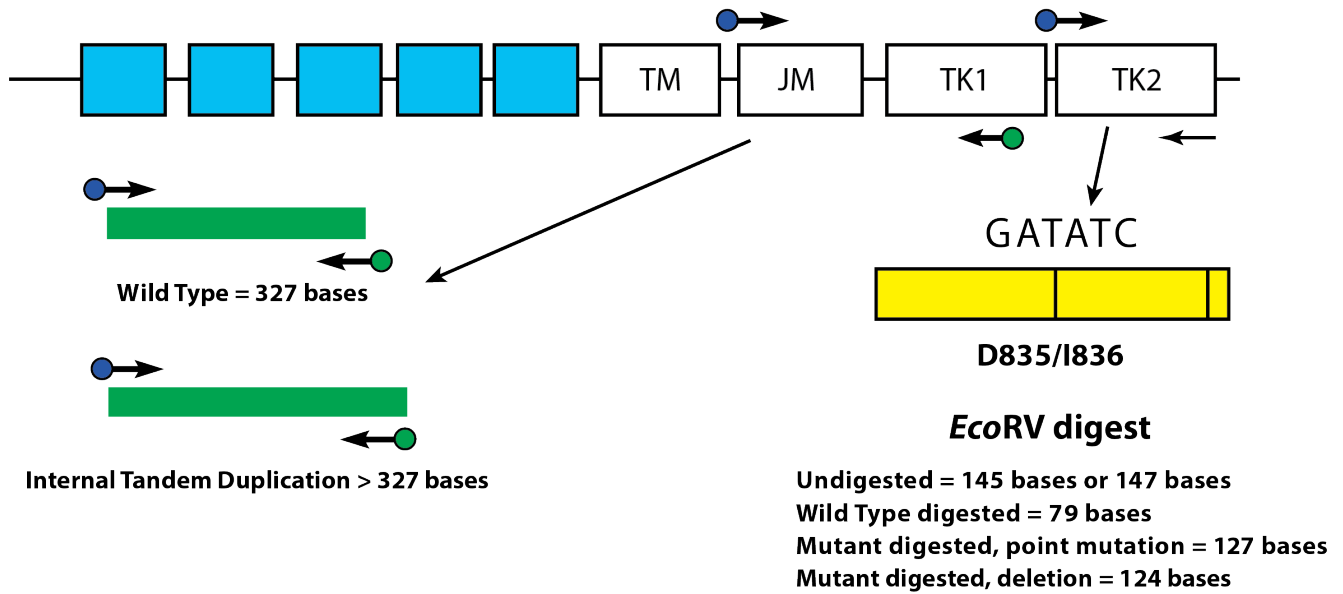

Depicted is a representation of the *FLT3* juxtamembrane (JM) region (TM = transmembrane) and the activating loop of the tyrosine kinase (TK) domain. Black arrows represent the relative positions of primers that target in and around the JM region for ITD or the activating loop of the kinase domain for TKD. Colored dots represent fluorophores on labeled primers. The yellow box has vertical black lines that represent the position of the *EcoRV* restriction digest sites.

## Reagents

Controls	Units in Assay
<i>FLT3</i> Extraction Control	1 x 1800 µL tube
<i>FLT3</i> ITD Master Mix	1 x 1500 µL tube
<i>FLT3</i> TKD Master Mix	1 x 1500 µL tube
<i>FLT3</i> ITD Positive Control	1 x 100 µL tube
<i>FLT3</i> TKD Positive Control	1 x 100 µL tube
<i>FLT3</i> No Template Control	1 x 200 µL tube

All reagents should be stored at -15 to -30 degrees C.

## Ordering Information

Catalog #	Products	Quantity
K-412-0381	LeukoStrat <sup>®</sup> CDx <i>FLT3</i> Mutation Assay	33 reactions
K-412-0391	LeukoStrat <sup>®</sup> CDx <i>FLT3</i> Mutation Assay Software	1 CD complimentary with purchase

## Available in Japan

# CDx FLT3 Mutation Assay

The only internationally standardized assay for *FLT3* Signal Ratio mutation analysis for assessment of acute myeloid leukemia (AML) patients eligible for treatment with Gilteritinib Fumarate or Quizartinib Hydrochloride.

## Intended Use

The LeukoStrat CDx *FLT3* Mutation Assay is a PCR-based, *in vitro* diagnostic test designed to detect internal tandem duplication (ITD) mutations and tyrosine kinase domain (TKD) mutations D835 and I836 in the *FLT3* gene in genomic DNA extracted from mononuclear cells obtained from peripheral blood or bone marrow aspirates of patients diagnosed with acute myelogenous leukemia.

The LeukoStrat CDx *FLT3* Mutation Assay is used as an aid in the assessment of patients with AML for whom Gilteritinib Fumarate treatment is being considered.

The LeukoStrat CDx *FLT3* Mutation Assay is used as an aid in the assessment of patients with AML for whom Quizartinib Hydrochloride treatment is being considered.

## Summary and Explanation of the Test

AML in general has a poor prognosis. Assessment of the mutation status of the *FLT3* (fms related tyrosine kinase 3) receptor gene in karyotype normal AML is the most important prognostic indicator of disease outcome, which is often substantial, as many studies in AML have shown that the presence of *FLT3* activating mutations portends a poor prognosis.<sup>1,2</sup> The LeukoStrat CDx *FLT3* Mutation Assay targets regions of the *FLT3* gene to identify ITD mutations and TKD mutations, such as the D835 and I836 mutations, and has been validated in an international clinical trial.

The LeukoStrat CDx *FLT3* Mutation Assay includes reagents, equipment, software and procedures for isolating mononuclear cells and extracting DNA from patient specimens to determine if *FLT3* mutations are present. DNA is amplified via PCR and the amplicons

are detected via capillary electrophoresis. *FLT3* mutation status is determined by the LeukoStrat CDx *FLT3* Software. A *FLT3* ITD and/or TKD mutation is reported as Positive if the mutant:wild-type signal ratio meets or exceeds the clinical cutoff of 0.05.

## Method Description

### ITD Mutations of *FLT3*

The LeukoStrat CDx *FLT3* Mutation Assay uses fluorescently labeled primers that are in the JM region. Wild-type *FLT3* alleles will amplify and produce a product at 327±1 bp as measured by this assay, while alleles that contain ITD mutations will produce a product that exceeds 330±1 bp (please see Figure, right).

### TKD Mutations of *FLT3*

The LeukoStrat CDx *FLT3* Mutation Assay uses primers that lie on either side of the TKD region. The *FLT3* target region is amplified using PCR and then an EcoRV restriction digest is performed. Wild-type alleles of the *FLT3* gene yield digestion products of 79±1 bp whereas mutant alleles yield products of 125±1 bp or 127±1 bp from the original undigested amplicon product of 145±1 bp or 147±1 bp, as measured by this assay (please see Figure, right).

## Reference

1. Murphy KM et al., A Clinical PCR/Capillary Electrophoresis Assay for the Detection of Internal Tandem Duplication and Point Mutation of the *FLT3* Gene. *J. Mol. Diag.* 5:96-102 (2003).
2. Yamamoto, Y., et al., Activating mutation of D835 within the activation loop of *FLT3* in human hematologic malignancies. *Blood*, 97(8):2434-9 (2001).

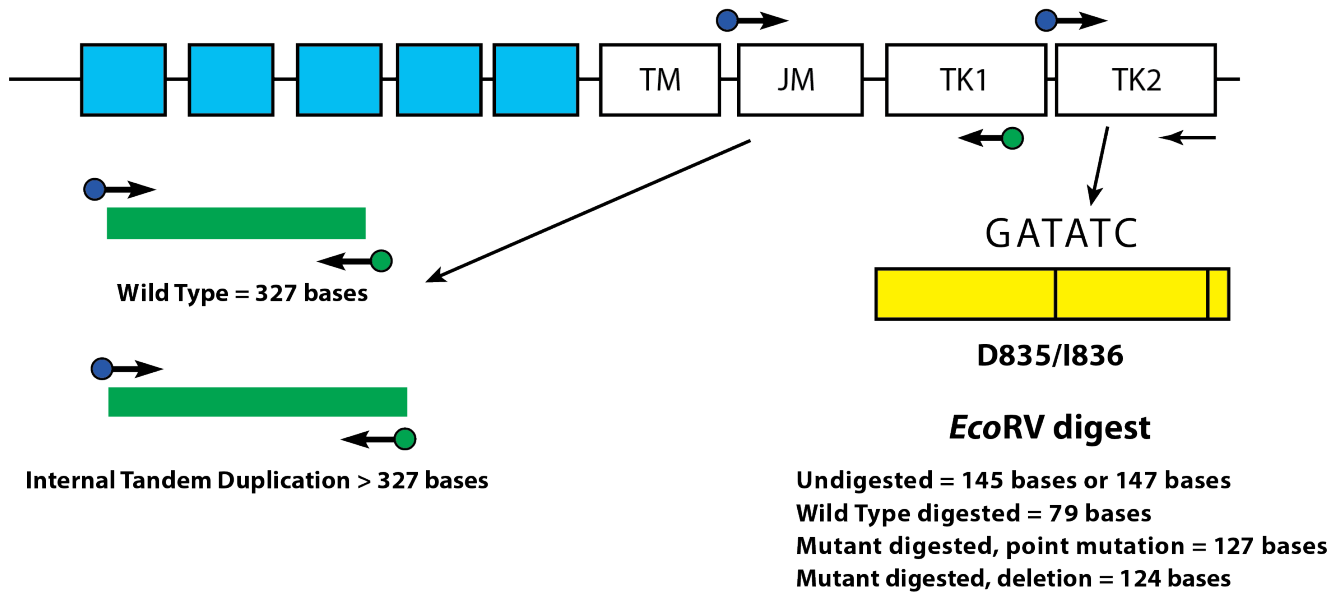

Depicted is a representation of the *FLT3* juxtamembrane (JM) region (TM = transmembrane) and the activating loop of the tyrosine kinase (TK) domain. Black arrows represent the relative positions of primers that target in and around the JM region for ITD or the activating loop of the kinase domain for TKD. Colored dots represent fluorophores on labeled primers. The yellow box has vertical black lines that represent the position of the *EcoRV* restriction digest sites.

## Reagents

Reagent Name	Units in Assay
<i>FLT3</i> Extraction Control	1 x 1800 µL tube
<i>FLT3</i> ITD Master Mix	1 x 1500 µL tube
<i>FLT3</i> TKD Master Mix	1 x 1500 µL tube
<i>FLT3</i> ITD Positive Control	1 x 100 µL tube
<i>FLT3</i> TKD Positive Control	1 x 100 µL tube
<i>FLT3</i> No Template Control	1 x 200 µL tube
Taq DNA Polymerase Enzyme	1 x 200 µL tube
<i>EcoRV</i> Enzyme	1 x 200 µL tube

All reagents should be stored at -15 to -30 degrees C.

## Ordering Information

Catalog #	Products	Quantity
K-412-0331	LeukoStrat <sup>®</sup> CDx <i>FLT3</i> Mutation Assay (Japan)	33 reactions
K-412-0341	LeukoStrat <sup>®</sup> CDx <i>FLT3</i> Mutation Assay Software (Japan)	1 CD complimentary with purchase

These are *in vitro* diagnostic products, and are available for sale or use within Japan.

# Gel and Capillary

## Research Use Only (RUO) Assay

### B-Cell Assays

94/ *IGH + IGK* B-Cell Clonality Assays

96/ *IGH* Gene Rearrangement Assays

98/ *IGH* Gene Clonality Assays

100/ *IGK* Gene Clonality Assays

102/ *IGL* Gene Clonality Assays

### T-Cell Assays

104/ *TCRB + TCRG* T-Cell Clonality Assays

106/ *TCRB* Gene Clonality Assays

108/ T-Cell Receptor Gama Gene Rearrangement Assays 2.0

110/ T-Cell Receptor Gama Gene Rearrangement Assays

112/ *TCRG* Gene Clonality Assays

114/ *TCRD* Gene Clonality Assays

### Translocation Assays

116/ *BCL1/JH* Translocation Assay

118/ *BCL2/JH t(14;18)* Translocation Assay

120/ *BCL2/JH* Translocation Assay

122/ *BCL2/JH t(9;22)* Translocation Assays

124/ *PML/RARα t(15;17)* Translocation Assays

### Mutation Assays

126/ *IGH* Somatic Hypermutation Assays v2.0

128/ *FLT3* Mutation Assays

#### WARRANTY AND LIABILITY

Invivoscribe, Inc. (Invivoscribe®) is committed to providing the highest quality products. Invivoscribe® warrants that the products meet or exceed the performance standards described in the Instructions For Use, as to products with such an insert. If a product is covered by product specifications and does not perform as specified, our policy is to replace the product or credit the full purchase price. No other warranties of any kind, expressed or implied, are provided by Invivoscribe®. Invivoscribe® liability shall not exceed the purchase price of the product. Invivoscribe shall have no liability for direct, indirect, consequential or incidental damages arising from the use, results of use, or inability to use its products; product efficacy under purchaser controlled conditions in purchaser's laboratory must be established and continually monitored through purchaser defined and controlled processes including but not limited to testing of positive, negative, and blank controls every time a sample is tested. Ordering, acceptance, and use of product constitutes purchaser acceptance of sole responsibility for assuring product efficacy and purchaser agreement to the limitation of liability set forth in this paragraph.

NOTICE: Many of these products in the section that follows are covered by one or more of the following: European Patent Number 1549764, European Patent Number 2418287, European Patent Number 2460889, Japanese Patent Number 4708029, United States Patent 8859748, United States Patent 10280462, and related pending and future applications. All of these patents and applications are licensed exclusively to Invivoscribe, Inc. Additional patents licensed to Invivoscribe covering some of these products apply elsewhere.

These products require nucleic acid amplification methods such as Polymerase Chain Reaction (PCR). No license under these patents to use amplification processes or enzymes is conveyed expressly or by implication to the purchaser by the purchase of these products.

# Gel and Capillary

Invivoscribe offers an array of assays for B- and T-cell gene clonality/rearrangements, mutations, and chromosome translocations for the study of hematologic malignancies.

These (RUO) assays are available for either ABI capillary electrophoresis fluorescence, or PAGE/agarose gel detection, and contain the PCR master mixes, recommended controls, and Instructions For Use.

On the following pages, you will find detailed information on each RUO assay, including: assay use, background information, typical output data, kit contents, and ordering information. These assays are available in regular sizes (30 or 33 reactions) or high-volume MegaKit formats (300 or 330 reactions).

These pages contain Research Use Only products which are not for use in diagnostic procedures. Research Use Only (RUO) assays are not for sale in Europe and other global markets where equivalent CE-IVD assays are available and registered with the appropriate regulatory agencies. Refer to the preceding pages for information regarding our IdentiClone® and LeukoStrat® CE-IVD Assays.

For more information, please visit [www.invivoscribe.com](http://www.invivoscribe.com)

# Gel and Capillary

IGH + IGK B-Cell Clonality Assays

Research Use Only (RUO) Assay

## IGH + IGK B-Cell Clonality Assays

### Assay Use

IGH + IGK B-Cell Clonality Assays are useful for studies involving:

- Identification of clonal B-cell populations highly suggestive of B-cell malignancies
- Lineage determination of leukemias and lymphomas
- Monitoring and evaluation of disease recurrence
- Detection and assessment of residual disease
- Evaluation of new research and methods in malignancy studies

### Summary and Explanation of the Test

Five PCR master mixes are included in these test kits to test for rearrangements of both IGH and IGK. IGH Tubes A, B, and C target the conserved framework 1, 2, and 3 regions (respectively) within the variable (V<sub>H</sub>) region and the joining (J<sub>H</sub>) region of the IGH locus. IGK tubes A and B target the variable (V<sub>K</sub>), intragenic and joining (J<sub>K</sub>), and kappa deleting element (K<sub>de</sub>) regions of the IGK locus.

Positive and negative controls, as well as Specimen Control Size Ladder Master Mix are included. PCR products can be analyzed by capillary electrophoresis or heteroduplex analysis. Clonality is indicated if any one of the master mixes generates clonal products.

### Background

The immunoglobulin heavy chain (IGH) gene locus on chromosome 14 (14q32.33, formerly 14q32.3) includes 46-52 functional and 30 nonfunctional variable (V<sub>H</sub>), 27 functional diversity (D<sub>H</sub>), and 6 functional joining (J<sub>H</sub>) gene segments spread over 1250 kilobases.<sup>1,2</sup> The most frequently used V<sub>H</sub> gene segments in normal and malignant B cells belong to V<sub>H</sub>3, V<sub>H</sub>4, and V<sub>H</sub>1 families, which together cover 75-95% of V<sub>H</sub> usage. The V<sub>H</sub> gene segments contain three framework regions (FR) and two complementarity determining regions (CDR). The FRs are characterized by their similarity among the various V<sub>H</sub> segments, whereas the CDRs are highly different even within the same V<sub>H</sub> family. The CDRs represent the preferred target sequences for somatic hypermutations; however, somatic mutations can also occur in the FRs. Therefore, family-specific primers in the three different FRs were designed to increase the detection rate of clonal IGH B-cell populations and decrease the occurrence of false-negative results due to somatic hypermutation in primer binding sites.<sup>1</sup>

The human immunoglobulin kappa (IGK) light chain locus on the short arm of chromosome 2 (2p11.2) spans 1820 kb. It is made up of 76 variable (V<sub>K</sub>) gene segments belonging to seven subgroups, five joining (J<sub>K</sub>) gene segments, and one constant (C<sub>K</sub>) gene segment. Productive assembly of the kappa gene is successful in about 60% of human B lymphocytes<sup>2</sup>; however, even when unsuccessful, clonal B cells generally retain the rearranged kappa genes. The V<sub>K</sub> segments encode the first 95 N-terminal amino acids. Positions 96-108 are encoded by one of five joining (J<sub>K</sub>) gene segments. The constant (C<sub>K</sub>) portion of the kappa light chain (amino acids 109-214) is encoded by a single constant (C<sub>K</sub>) region separated from the J<sub>K</sub> region by an intron.

The length of the hypervariable CDR3 in kappa light chain genes is limited and rearrangements in this region display significant skewing (platykurtosis).<sup>3</sup> Therefore, clonal CDR3 products generated from this region are easily and reliably identified by heteroduplex analysis or capillary electrophoresis.

### Specimen Requirements

- 5 mL of peripheral blood, bone marrow biopsy, or bone marrow aspirate anti-coagulated with heparin or EDTA; or,
- Minimum 5 mm cube of tissue; or,
- 3 µg of genomic DNA; or,
- Formalin-fixed, paraffin-embedded (FFPE) tissue or slides.

### Reference

1. M Hummel et al., *Leukemia* 17: 2266-2272 (2003).
2. AW Langerak et al., *Leukemia* 17: 2272-2275 (2003).
3. EP Rock, PR Sibbald, MM Davis, and YH Chien. *J. Exp. Med.* 179(1): 323-328 (1994).
4. JJM van Dongen et al., *Leukemia* 17: 2257-2317 (2003).



This assay is based on the EuroClonality/BIOMED-2 Concerted Action BMH4-CT98-3936.

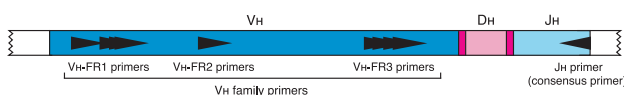

IGH Tube A: 6 V<sub>H</sub>-FR1 Primers + J<sub>H</sub> Consensus Primer  
IGH Tube B: 7 V<sub>H</sub>-FR2 Primers + J<sub>H</sub> Consensus Primer  
IGH Tube C: 7 V<sub>H</sub>-FR3 Primers + J<sub>H</sub> Consensus Primer

Figure Legend: Simple representation of the organization of a rearranged immunoglobulin heavy chain (IGH) gene on chromosome 14 and the immunoglobulin kappa light chain gene on chromosome 2p11.2. Black arrows represent the relative positions of primers that target the conserved framework regions (FR1-3) and the downstream consensus J<sub>H</sub> gene segments for IGH and the V<sub>K</sub>, J<sub>K</sub>, INTR and K<sub>de</sub> primers which are included in the IGK master mix tubes.

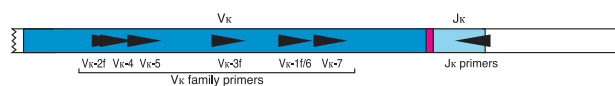

IGK tube A: 6 V<sub>K</sub> primers + 2 J<sub>K</sub> primers

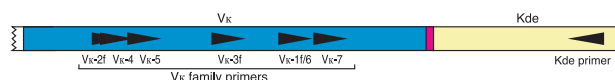

IGK tube B: 6 V<sub>K</sub> primers and INTR primer + 1 k<sub>de</sub> primer

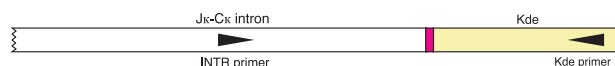

## Reagents

Controls	Concentration	Units in Assay	Units in Assay MegaKit
IVS-0030 Clonal Control DNA	200 µg/mL	1 x 100 µL tube	5 x 100 µL tubes
IVS-0019 Clonal Control DNA	200 µg/mL	1 x 100 µL tube	5 x 100 µL tubes
IVS-0007 Clonal Control DNA	200 µg/mL	1 x 100 µL tube	5 x 100 µL tubes
IVS-0000 Polyclonal Control DNA	200 µg/mL	1 x 100 µL tube	5 x 100 µL tubes
Master Mixes	Target	Units in Assay	Units in Assay MegaKit
<i>IGH</i> Tube A	Framework 1 + J <sub>H</sub>	1 x 1500 µL tube	10 x 1500 µL tubes
<i>IGH</i> Tube B	Framework 2 + J <sub>H</sub>	1 x 1500 µL tube	10 x 1500 µL tubes
<i>IGH</i> Tube C	Framework 3 + J <sub>H</sub>	1 x 1500 µL tube	10 x 1500 µL tubes
<i>IGK</i> Tube A	V <sub>K</sub> -J <sub>K</sub>	1 x 1500 µL tube	10 x 1500 µL tubes
<i>IGK</i> Tube B	V <sub>K</sub> -K <sub>de</sub>	1 x 1500 µL tube	10 x 1500 µL tubes
Specimen Control Size Ladder	Multiple Genes	1 x 1500 µL tube	10 x 1500 µL tubes

## Gel Electrophoresis Detection

The data shown was generated using the master mix indicated. Amplified products were heteroduplexed and then run on a 6% non-denaturing polyacrylamide/TBE gel. Lane 1 is data generated testing an alternative 100% clonal control DNA; lane 2 is generated testing the recommended 100% clonal control DNA; lane 3 is data generated testing a 10% dilution of the recommended clonal control DNA; and, lane 4 is data generated testing IVS-0000 Polyclonal Control DNA (Cat# 4-092-0010). This DNA is used as a negative control for many of our tests. A standard 100 base pair DNA size ladder was run in the lanes flanking the test samples.

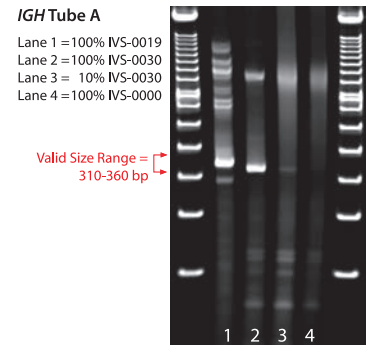

## Capillary Electrophoresis Detection (ABI)

The data shown was generated using the master mix indicated. Amplified products were run on an ABI 3100 instrument. For the master mix: Panel 1 displays data generated testing an alternative 100% clonal control DNA; panel 2 displays data generated testing the recommended 100% clonal control DNA; panel 3 displays data generated testing a 10% dilution of the recommended clonal control DNA; and, panel 4 displays data generated testing the IVS-0000 Polyclonal Control DNA (Cat# 4-092-0010). Our IVS-0000 DNA is often tested to provide information regarding valid size ranges for each master mix.

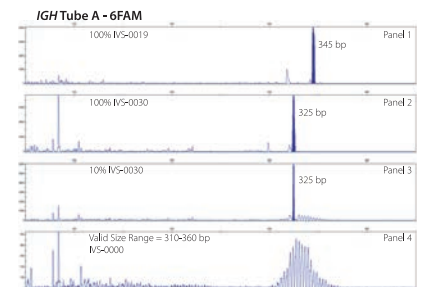

## Ordering Information

Catalog #	Products	Quantity
1-100-0010	<i>IGH + IGK</i> B-Cell Clonality Assay - Gel Detection	33 reactions
1-100-0020	<i>IGH + IGK</i> B-Cell Clonality Assay MegaKit - Gel Detection	330 reactions
1-100-0031	<i>IGH + IGK</i> B-Cell Clonality Assay - ABI Fluorescence Detection	33 reactions
1-100-0041	<i>IGH + IGK</i> B-Cell Clonality Assay MegaKit - ABI Fluorescence Detection	330 reactions

## IGH Gene Rearrangement Assays

### Assay Use

IGH Gene Rearrangement Assays are useful for studies involving:

- Identification of clonal B-cell populations highly suggestive of B-cell malignancies
- Lineage determination of leukemias and lymphomas
- Monitoring and evaluation of disease recurrence
- Detection and assessment of residual disease
- Evaluation of new research and methods in malignancy studies

### Summary and Explanation of the Test

Genomic DNA is amplified using three PCR master mixes that target the three conserved framework regions (FR1, FR2, and FR3) of the IGH gene and the joining (JH) region. These regions flank the unique, hypervariable, antigen-binding, complementarity determining region 3 (CDR3). All positive and negative DNA controls, as well as an Amplification Control master mix, are included. The limit of detection of this assay is one clonal B cell in a background of a hundred normal cells. PCR products can be analyzed by capillary electrophoresis or standard gel electrophoresis with ethidium bromide staining. Clonality is indicated if one or more of the three framework master mixes generates clonal products.

### Background

Genes encoding immunoglobulin heavy chain (IGH) molecules are assembled from multiple polymorphic gene segments that undergo rearrangement and selection during B-cell development.<sup>2</sup> Rearrangement of these variable (V<sub>H</sub>), diversity (D<sub>H</sub>), and joining (J<sub>H</sub>) genetic segments result in VDJ products of unique length and sequence.<sup>1,2</sup> Clonal IGH rearrangements can be rapidly identified through analyses of the size distributions of DNA products amplified from conserved sequences that flank this region.<sup>2</sup> For example, DNA isolated from a normal polyclonal population of B cells produces a Gaussian distribution (bell-shaped size curve) of amplified products; whereas, DNA amplified from a clonal B-cell population generates one or two product(s) of unique size that reflect proliferation of a single rearranged clone.<sup>1</sup> In comparison, southern blot analysis requires 1-2 weeks, is significantly less sensitive, and requires approximately one hundred times more DNA than PCR-based assays, which can be completed in 4-5 hours.<sup>1</sup> In addition, tests of samples previously designated Quantity Not Sufficient (QNS), such as formalin-fixed, paraffin embedded (FFPE) tissue sections, routinely produce a valid result with PCR methods.

### Specimen Requirements

- 5 mL of peripheral blood, bone marrow biopsy, or bone marrow aspirate anti-coagulated with heparin or EDTA; or,
- Minimum 5 mm cube of tissue; or,
- 2 µg of genomic DNA; or,
- Formalin-fixed, paraffin-embedded tissue or slides.

### Reference

1. JE Miller, SS Wilson, DL Jaye, and M Kronenberg. *J. Mol. Diag.* 4: 101-117 (1999).
2. S Tonegawa. *Nature* 302: 575-581 (1983).

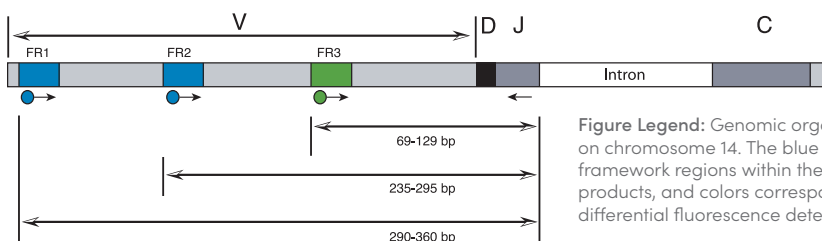

**Figure Legend:** Genomic organization of a rearranged immunoglobulin heavy chain gene on chromosome 14. The blue and green arrows represent primers targeting the conserved framework regions within the variable region gene. The relative location, size range of valid products, and colors correspond to the products generated from each of these regions when differential fluorescence detection methods are used.



# Gel and Capillary

*IGH* Gene Rearrangement Assays

Research Use Only (RUO) Assay

## Reagents

Controls	Concentration	Units in Assay	Units in Assay MegaKit
IVS-0030 Clonal Control DNA	200 µg/mL	1 x 100 µL tube	5 x 100 µL tubes
IVS-0029 Clonal Control DNA	200 µg/mL	1 x 100 µL tube	5 x 100 µL tubes
IVS-0000 Polyclonal Control DNA	200 µg/mL	1 x 100 µL tube	5 x 100 µL tubes
Master Mixes	Target	Units in Assay	Units in Assay MegaKit
<i>IGH</i> Framework 1	Framework 1 + J <sub>H</sub>	1 x 1500 µL tube	10 x 1500 µL tubes
<i>IGH</i> Framework 2	Framework 2 + J <sub>H</sub>	1 x 1500 µL tube	10 x 1500 µL tubes
<i>IGH</i> Framework 3	Framework 3 + J <sub>H</sub>	1 x 1500 µL tube	10 x 1500 µL tubes
Amplification Control	<i>HLA-DQα</i>	1 x 1500 µL tube	10 x 1500 µL tubes

## Gel Electrophoresis Detection

The data shown was generated using the master mix indicated. Amplified products were run on a 6% non-denaturing polyacrylamide/TBE gel. Lane 1 is data generated testing an alternative 100% clonal control DNA; lane 2 is data generated testing the recommended 100% clonal control DNA; lane 3 is data generated testing a 10% dilution of the recommended clonal control DNA; and, lane 4 is data generated testing IVS-0000 Polyclonal Control DNA (Cat# 4-092-0010). IVS-0000 is used as a negative control for many of our tests. A standard 100 base pair DNA size ladder was run in the lanes flanking the test samples.

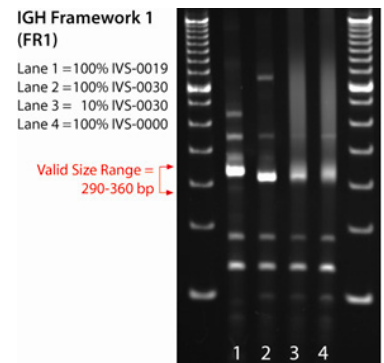

## Capillary Electrophoresis Detection (ABI)

The data shown was generated using the master mix indicated. Amplified products were run on an ABI 3100 instrument. Panel 1 displays data generated testing an alternative 100% clonal control DNA; panel 2 displays data generated testing the recommended 100% clonal control DNA; panel 3 displays data generated testing a 10% dilution of the recommended clonal control DNA; and, panel 4 displays data generated testing the IVS-0000 Polyclonal Control DNA (Cat# 4-092-0010). Our IVS-0000 DNA is often tested to provide information regarding valid size ranges for each master mix.

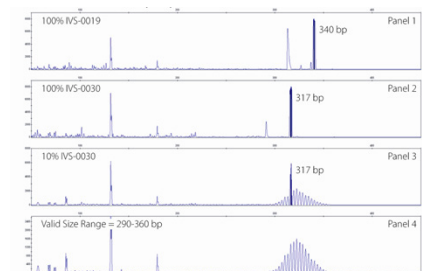

## Ordering Information

Catalog #	Products	Quantity
1-101-0010	<i>IGH</i> Gene Rearrangement Assay - Gel Detection	30 reactions
1-101-0030	<i>IGH</i> Gene Rearrangement Assay MegaKit - Gel Detection	300 reactions
1-101-0051	<i>IGH</i> Gene Rearrangement Assay - ABI Fluorescence Detection	30 reactions
1-101-0071	<i>IGH</i> Gene Rearrangement Assay MegaKit - ABI Fluorescence Detection	300 reactions

## IGH Gene Clonality Assays

### Assay Use

IGH Gene Clonality Assays are useful for studies involving:

- Identification of clonal B-cell populations highly suggestive of B-cell malignancies
- Lineage determination of leukemias and lymphomas
- Monitoring and evaluation of disease recurrence
- Detection and assessment of residual disease
- Evaluation of new research and methods in malignancy studies

### Summary and Explanation of the Test

Five master mixes target conserved regions within the variable (V<sub>H</sub>), diversity (D<sub>H</sub>), and the joining (J<sub>H</sub>) regions that flank the unique hypervariable, antigen-binding, complementarity determining region 3 (CDR3). Tube A contains six framework region 1 (FR1) primers and a consensus J<sub>H</sub> region primer. Tube B contains seven framework region 2 (FR2) primers and a consensus J<sub>H</sub> primer. Tube C contains seven framework region 3 (FR3) primers and a consensus J<sub>H</sub> primer. Tube D contains six D<sub>H</sub> region primers and a consensus J<sub>H</sub> region primer. Tube E contains a D<sub>H7</sub> region primer and a consensus J<sub>H</sub> primer. Positive and negative controls, as well as the Specimen Control Size Ladder Master Mix are included. PCR products can be analyzed by capillary electrophoresis or heteroduplex analysis. Clonality is indicated if any one of the master mixes generates a clonal product.

### Background

The immunoglobulin heavy chain (IGH) gene locus on chromosome 14 (14q32.33, formerly 14q32.3) includes 46–52 functional and 30 nonfunctional variable (V<sub>H</sub>), 27 functional diversity (D<sub>H</sub>), and 6 functional joining (J<sub>H</sub>) gene segments spread over 1250 kilobases.<sup>1,2</sup> The most frequently used V<sub>H</sub> gene segments in normal and malignant B cells belong to the V<sub>H3</sub>, V<sub>H4</sub>, and V<sub>H1</sub> family, together covering

75–95% of V<sub>H</sub> usage. The V<sub>H</sub> gene segments contain three framework regions (FR) and two complementarity determining regions (CDR).

The FRs are characterized by their similarity among the various V<sub>H</sub> segments, whereas the CDRs are highly different even within the same V<sub>H</sub> family. The CDRs represent the preferred target sequences for somatic hypermutations; however, somatic mutations can also occur in the FRs. Therefore, family-specific primers in the three different FRs were designed to increase the detection rate of clonal IGH B-cell populations and decrease the occurrence of false-negative results due to somatic hypermutation in primer binding sites.<sup>1</sup> In addition to V<sub>H</sub>-J<sub>H</sub> rearrangements, incomplete D<sub>H</sub>-J<sub>H</sub> rearrangements have been found in mature and immature B-cell malignancies. Therefore, D<sub>H</sub>-J<sub>H</sub> PCR analysis may be of added value for clonality assessment.<sup>2</sup>

### Specimen Requirements

- 5 mL of peripheral blood, bone marrow biopsy, or bone marrow aspirate anti-coagulated with heparin or EDTA; or,
- Minimum 5 mm cube of tissue; or,
- 3 µg of genomic DNA; or,
- Formalin-fixed, paraffin-embedded (FFPE) tissue or slides.

### Reference

1. M Hummel et al., *Leukemia* 17:2266–2272 (2003).
2. AW Langerak et al., *Leukemia* 17:2272–2275 (2003).
3. JJM van Dongen et al., *Leukemia* 17:2257–2317 (2003).



This assay is based on the EuroClonality/BIOMED-2 Concerted Action BMH4-CT98-3936.

**Figure Legend:** Simple representation of the organization of a rearranged immunoglobulin heavy chain gene on chromosome 14. Black arrows represent the relative positions of primers that target the conserved framework (FR1–3) and diversity (D<sub>H</sub>1–7) regions, and the downstream consensus J<sub>H</sub> gene segments. The amplicon products generated from each of these regions can be differentially detected when fluorescent primer sets are used with capillary electrophoresis instruments that employ differential fluorescence detection.

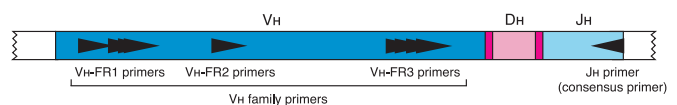

- Tube A: 6 V<sub>H</sub> -FR1 Primers + J<sub>H</sub> Consensus Primer  
 Tube B: 7 V<sub>H</sub> -FR2 Primers + J<sub>H</sub> Consensus Primer  
 Tube C: 7 V<sub>H</sub> -FR3 Primers + J<sub>H</sub> Consensus Primer



- Tube D: 6 D<sub>H</sub> Primers + J<sub>H</sub> Consensus Primer  
 Tube E: D<sub>H</sub> 7 Primer + J<sub>H</sub> Consensus Primer

## Reagents

Controls	Concentration	Units in Assay	Units in Assay MegaKit
IVS-0030 Clonal Control DNA	200 µg/mL	1 x 100 µL tube	5 x 100 µL tubes
IVS-0019 Clonal Control DNA	200 µg/mL	1 x 100 µL tube	5 x 100 µL tubes
IVS-0024 Clonal Control DNA	200 µg/mL	1 x 100 µL tube	5 x 100 µL tubes
IVS-0008 Clonal Control DNA	200 µg/mL	1 x 100 µL tube	5 x 100 µL tubes
IVS-0000 Polyclonal Control DNA	200 µg/mL	1 x 100 µL tube	5 x 100 µL tubes
Master Mixes	Target	Units in Assay	Units in Assay MegaKit
<i>IGH</i> Tube A	Framework 1 + J <sub>H</sub>	1 x 1500 µL tube	10 x 1500 µL tubes
<i>IGH</i> Tube B	Framework 2 + J <sub>H</sub>	1 x 1500 µL tube	10 x 1500 µL tubes
<i>IGH</i> Tube C	Framework 3 + J <sub>H</sub>	1 x 1500 µL tube	10 x 1500 µL tubes
<i>IGH</i> Tube D	DH1-6 + J <sub>H</sub>	1 x 1500 µL tube	10 x 1500 µL tubes
<i>IGH</i> Tube E	DH7 + J <sub>H</sub>	1 x 1500 µL tube	10 x 1500 µL tubes
Specimen Control Size Ladder	Multiple Genes	1 x 1500 µL tube	10 x 1500 µL tubes

## Gel Electrophoresis Detection

The data shown was generated using the master mix indicated. Amplified products were heteroduplexed and then run on a 6% non-denaturing polyacrylamide/TBE gel. Lane 1 is data generated testing an alternative 100% clonal control DNA; lane 2 data is generated testing the recommended 100% clonal control DNA; lane 3 is data generated testing a 10% dilution of the recommended clonal control DNA; and, lane 4 is data generated testing IVS-0000 Polyclonal Control DNA (Cat# 4-092-0010). IVS-0000 is used as a negative control for many of our tests. A standard 100 base pair DNA size ladder was run in the lanes flanking the test samples.

### *IGH* Tube A

Lane 1 = 100% IVS-0019  
Lane 2 = 100% IVS-0030  
Lane 3 = 10% IVS-0030  
Lane 4 = 100% IVS-0000

Valid Size Range =  
310-360 bp

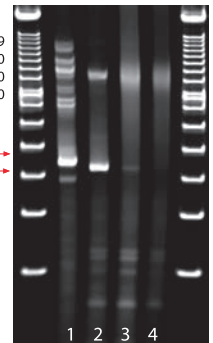

## Capillary Electrophoresis Detection (ABI)

The data shown was generated using the master mix indicated. Amplified products were run on an ABI 3100 instrument. For the master mix: Panel 1 displays data generated testing an alternative 100% clonal control DNA; panel 2 displays data generated testing the recommended 100% clonal control DNA; panel 3 displays data generated testing a 10% dilution of the recommended clonal control DNA; and, panel 4 displays data generated testing the IVS-0000 Polyclonal Control DNA (Cat# 4-092-0010). Our IVS-0000 DNA is often tested to provide information regarding valid size ranges for each master mix.

### *IGH* Tube A - 6FAM

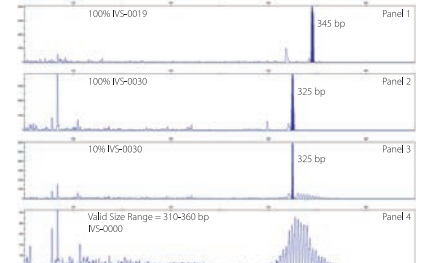

## Ordering Information

Catalog #	Products	Quantity
1-101-0020	<i>IGH</i> Gene Clonality Assay - Gel Detection	33 reactions
1-101-0040	<i>IGH</i> Gene Clonality Assay MegaKit - Gel Detection	330 reactions
1-101-0061	<i>IGH</i> Gene Clonality Assay - ABI Fluorescence Detection	33 reactions
1-101-0081	<i>IGH</i> Gene Clonality Assay MegaKit - ABI Fluorescence Detection	330 reactions

## IGK Gene Clonality Assays

### Assay Use

IGK Gene Clonality Assays are useful for studies involving:

- Identification of clonal B-cell populations highly suggestive of B-cell malignancies
- Lineage determination of leukemias and lymphomas
- Monitoring and evaluation of disease recurrence
- Detection and assessment of residual disease
- Evaluation of new research and methods in malignancy studies

### Summary and Explanation of the Test

Two master mixes target conserved regions within the variable (Vk1-7) and the joining (Jk1-5) regions that flank the unique hypervariable, antigen-binding, complementarity determining region 3 (CDR3). Other primers target the K<sub>de</sub> and intragenic regions.

Tube A contains six upstream primers and two Jk region primers. Tube B contains six upstream Vk region primers, an upstream intragenic primer and a downstream K<sub>de</sub> primer. Positive and negative controls, as well as a Specimen Control Size Ladder Master Mix, are included. PCR products can be analyzed by capillary electrophoresis or heteroduplex analysis. Clonality is indicated if any one of the master mixes generates clonal products.

### Background

The human immunoglobulin kappa (IGK) light chain locus on the short arm of chromosome 2 (2p12, formerly 2p11.2) spans 1820 kb. It is made up of 76 variable (Vk) gene segments belonging to 7 subgroups, 5 joining (Jk) gene segments, and one constant (Ck) gene segment. Productive assembly of the kappa gene is successful in about 60% of human B lymphocytes.<sup>1</sup> However, even when unsuccessful, clonal B cells generally retain the rearranged kappa genes. The Vk segments

encode the first 95 N-terminal amino acids. Positions 96-108 are encoded by one of five joining (Jk) gene segments. The constant (Ck) portion of the kappa light chain (amino acids 109-214) is encoded by a single constant (Ck) region separated from the Jk region by an intron. The length of the hypervariable complementarity determining region 3 (CDR3) in kappa light chain genes is limited and rearrangements in this region display significant skewing (platykurtosis).<sup>2</sup>

Therefore, clonal CDR3 products generated from this region are most easily and reliably identified by heteroduplex analysis using standard polyacrylamide gels. Alternatively, capillary electrophoresis or gene sequencing instruments coupled with differential fluorescence detection can be used for analysis.

### Specimen Requirements

- 5 mL of peripheral blood, bone marrow biopsy, or bone marrow aspirate anti-coagulated with heparin or EDTA; or,
- Minimum 5 mm cube of tissue; or,
- 2 µg of genomic DNA; or,
- Formalin-fixed, paraffin-embedded (FFPE) tissue or slides.

### Reference

1. AW Langerak et al., *Leukemia* 17: 2275-2280 (2003).
2. EP Rock, PR Sibbald, MM Davis, and YH Chien. *J. Exp. Med.* 179(1): 323-328 (1994).
3. JJM van Dongen et al., *Leukemia* 17: 2257-2317 (2003).



This assay is based on the EuroClonality/BIOMED-2 Concerted Action BMH4-CT98-3936.

**Figure Legend:** Schematic diagram of the immunoglobulin kappa light chain gene complex on chromosome 2p11.2. Shown are the relative positions and orientations for the V<sub>k</sub>-J<sub>k</sub> and K<sub>de</sub> primers, which are included in the IGK master mix tubes.

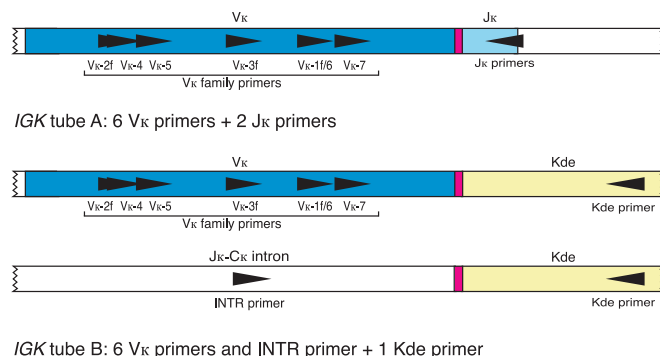

## Reagents

Controls	Concentration	Units in Assay	Units in Assay MegaKit
IVS-0007 Clonal Control DNA	200 µg/mL	1 x 100 µL tube	5 x 100 µL tubes
IVS-0000 Polyclonal Control DNA	200 µg/mL	1 x 100 µL tube	5 x 100 µL tubes
Master Mixes	Target	Units in Assay	Units in Assay MegaKit
IGK Tube A	Vk-Jk	1 x 1500 µL tube	10 x 1500 µL tubes
IGK Tube B	Vk-K <sub>de</sub>	1 x 1500 µL tube	10 x 1500 µL tubes
Specimen Control Size Ladder	Multiple Genes	1 x 1500 µL tube	10 x 1500 µL tubes

## Gel Electrophoresis Detection

The data shown was generated using the master mix indicated. Amplified products were heteroduplexed and then run on a 6% non-denaturing polyacrylamide/TBE gel. Lane 1 is data generated testing an alternative 100% clonal control DNA; lane 2 is data generated testing the recommended 100% clonal control DNA; lane 3 is data generated testing a 10% dilution of the recommended clonal control DNA; and, lane 4 is data generated testing IVS-0000 Polyclonal Control DNA (Cat# 4-092-0010). The IVS-0000 control is used as a negative control for many of our tests. A standard 100 base pair DNA size ladder was run in the lanes flanking the test samples.

### IGK Tube A

Lane 1 = 100% IVS-0019  
 Lane 2 = 100% IVS-0007  
 Lane 3 = 10% IVS-0007  
 Lane 4 = 100% IVS-0000

Valid Size Range =  
 120-160 bp,  
 190-210 bp,  
 & 260-300 bp

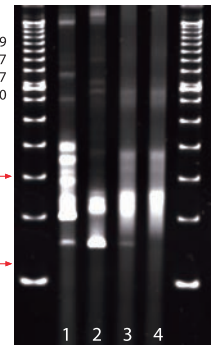

## Capillary Electrophoresis Detection (ABI)

The data shown was generated using the master mix indicated. Amplified products were run on an ABI 3100 instrument. Panel 1 displays data generated testing an alternative 100% clonal control DNA; panel 2 displays data generated testing the recommended 100% clonal control DNA; panel 3 displays data generated testing a 10% dilution of the recommended clonal control DNA; and, panel 4 displays data generated testing the IVS-0000 Polyclonal Control DNA (Cat# 4-092-0010). Our IVS-0000 DNA is often tested to provide information regarding valid size ranges for each master mix.

### IGK Tube A - 6FAM

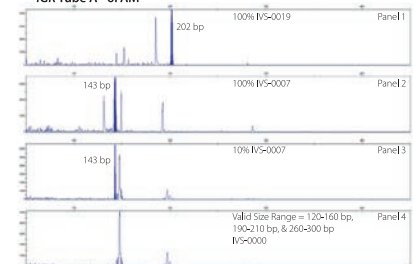

## Ordering Information

Catalog #	Products	Quantity
1-102-0020	IGK Gene Clonality Assay - Gel Detection	33 reactions
1-102-0030	IGK Gene Clonality Assay MegaKit - Gel Detection	330 reactions
1-102-0021	IGK Gene Clonality Assay - ABI Fluorescence Detection	33 reactions
1-102-0031	IGK Gene Clonality Assay MegaKit - ABI Fluorescence Detection	330 reactions

## IGL Gene Clonality Assays

### Assay Use

IGL Gene Clonality Assays are useful for studies involving:

- Identification of clonal B-cell populations highly suggestive of B-cell malignancies
- Lineage determination of leukemias and lymphomas
- Monitoring and evaluation of disease recurrence
- Detection and assessment of residual disease
- Evaluation of new research and methods in malignancy studies

### Summary and Explanation of the Test

The IGL Tube master mix targets conserved regions within the variable (V $\lambda$ 1-3) and the joining (J $\lambda$ 1-3) regions that flank the unique, hypervariable, antigen-binding, complementarity determining region 3 (CDR3). Positive and negative controls, as well as a Specimen Control Size Ladder Master Mix, are included. PCR products can be analyzed by capillary electrophoresis or heteroduplex analysis. Clonality is indicated if the master mix generates clonal products.

### Background

The human immunoglobulin lambda (*IGL*) light chain locus is located on the long arm of chromosome 22 (22q11.2) and spans 1050 kilobases. It is made up of 73-74 variable (V $\lambda$ ) gene segments (spread over 900 kilobases), 7-11 joining (J $\lambda$ ) gene segments and 7-11 constant (C $\lambda$ ) gene segments depending on the haplotypes. Of the 73-74 V $\lambda$  region genes, only 30-33 are functional and can be grouped into 11 families and 3 clans.<sup>1</sup> The J $\lambda$  and C $\lambda$  region genes are organized in tandem with a J $\lambda$  segment preceding a C $\lambda$  gene. Typically there are 7 J $\lambda$ -C $\lambda$  segments of which four are functional and encode the four Ig lambda isotypes.

IGL gene rearrangements are present in 5-10% of Ig kappa B-cell malignancies and in all Ig lambda B-cell malignancies. Therefore, V $\lambda$ -J $\lambda$  rearrangements potentially represent an attractive extra PCR target for clonality studies to compensate for false-negative IGH V $H$ -J $H$  PCR results mainly caused by somatic hypermutations. It should be noted that because of the limited size of the junctional region, it is extremely difficult to distinguish polyclonal from monoclonal rearrangements by running a simple agarose or polyacrylamide gel.<sup>1</sup> Therefore, clonal V $\lambda$ -J $\lambda$  PCR products are most easily and reliably identified by heteroduplex analysis using standard polyacrylamide gels. Alternatively, capillary electrophoresis or gene sequencing instruments coupled with differential fluorescence detection can be used for analysis.<sup>1</sup>

### Specimen Requirements

- 5 mL of peripheral blood, bone marrow biopsy, or bone marrow aspirate anti-coagulated with heparin or EDTA; or,
- Minimum 5 mm cube of tissue; or,
- 2  $\mu$ g of genomic DNA; or,
- Formalin-fixed, paraffin-embedded (FFPE) tissue or slides.

### Reference

1. F Davi et al., *Leukemia* 17:2280-2283 (2003).
2. JJM van Dongen et al., *Leukemia* 17:2257-2317 (2003).



This assay is based on the EuroClonality/BIMED-2 Concerted Action BMH4-CT98-3936.

**Figure Legend:** Schematic diagram of the immunoglobulin lambda light chain gene complex on chromosome 22q11.2. Shown are the relative positions and orientations for the V $\lambda$  and J $\lambda$  primers, which are included in the IGL master mix tube. The two V $\lambda$  primers only target V $\lambda$ 1, 2, and 3 because these three V families cover approximately 70% of rearrangeable V $\lambda$  gene segments, and approximately 90% of all IGL gene rearrangements involve these three families. Similarly, the single J $\lambda$  primer only targets J $\lambda$ 1, 2, and 3 because these three J segments are involved in 98% of all IGL gene rearrangements.

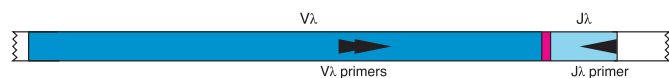

IGL tube: 2 V $\lambda$  primers + 1 J $\lambda$  primer

## Reagents

Controls	Concentration	Units in Assay	Units in Assay MegaKit
IVS-0010 Clonal Control DNA	200 µg/mL	1 x 100 µL tube	5 x 100 µL tubes
IVS-0029 Clonal Control DNA	200 µg/mL	1 x 100 µL tube	5 x 100 µL tubes
IVS-0000 Polyclonal Control DNA	200 µg/mL	1 x 100 µL tube	5 x 100 µL tubes
Master Mixes	Target	Units in Assay	Units in Assay MegaKit
IGL Tube	Vλ-Jλ	1 x 1500 µL tube	10 x 1500 µL tubes
Specimen Control Size Ladder	Multiple Genes	1 x 1500 µL tube	10 x 1500 µL tubes

## Gel Electrophoresis Detection

The data shown was generated using the master mix indicated. Amplified products were heteroduplexed and then run on a 6% non-denaturing polyacrylamide/TBE gel. Lane 1 is data generated testing an alternative 100% clonal control DNA; lane 2 is data generated testing the recommended 100% clonal control DNA; lane 3 is data generated testing a 10% dilution of the recommended clonal control DNA; and, lane 4 is data generated testing IVS-0000 Polyclonal Control DNA (Cat# 4-092-0010). The IVS-0000 control is used as a negative control for many of our tests. A standard 100 base pair DNA size ladder was run in the lanes flanking the test samples.

### IGL Tube

Lane 1 = 100% IVS-0029  
Lane 2 = 100% IVS-0010  
Lane 3 = 10% IVS-0010  
Lane 4 = 100% IVS-0000

Valid Size Range =  
135-170 bp

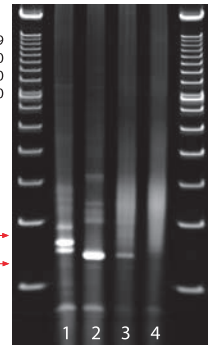

## Capillary Electrophoresis Detection (ABI)

The data shown was generated using the master mix indicated. Amplified products were run on an ABI 3100 instrument. Panel 1 displays data generated testing an alternative 100% clonal control DNA; panel 2 displays data generated testing the recommended 100% clonal control DNA; panel 3 displays data generated testing a 10% dilution of the recommended clonal control DNA; and, panel 4 displays data generated testing the IVS-000 Polyclonal Control DNA (Cat# 4-092-0010). Our IVS-0000 DNA is often tested to provide information regarding valid size ranges for each master mix.

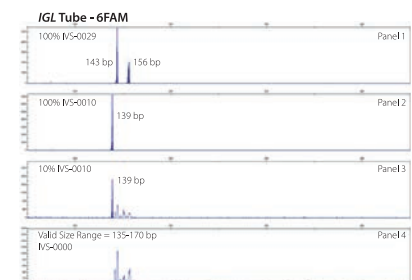

## Ordering Information

Catalog #	Products	Quantity
1-103-0010	IGL Gene Clonality Assay - Gel Detection	33 reactions
1-103-0020	IGL Gene Clonality Assay MegaKit - Gel Detection	330 reactions
1-103-0011	IGL Gene Clonality Assay - ABI Fluorescence Detection	33 reactions
1-103-0021	IGL Gene Clonality Assay MegaKit - ABI Fluorescence Detection	330 reactions

## TCRB + TCRG T-Cell Clonality Assays

### Assay Use

TCRB + TCRG T-Cell Clonality Assays are useful for studies involving:

- Identification of clonal T-cell populations highly suggestive of T-cell malignancies
- Lineage determination of leukemias and lymphomas
- Monitoring and evaluation of disease recurrence
- Detection and assessment of residual disease
- Evaluation of new research and methods in malignancy studies

### Summary and Explanation of the Test

Five master mixes are included in these test kits to test for rearrangements of both *TRB* (formerly known as *TCRB*) and *TRG* (formerly known as *TCRG*). *TCRB* Tubes A and B target framework regions within the variable region, and the joining region of the T-cell receptor beta locus. *TCRB* Tube C targets the diversity and joining regions. *TCRG* Tubes A and B target framework regions within the variable region, and the joining region of the T-cell receptor gamma locus.

Positive and negative controls, as well as a Specimen Control Size Ladder Master Mix, are included. PCR products can be analyzed by capillary electrophoresis or heteroduplex analysis. Clonality is indicated if any one of the master mixes generates clonal products.

### Background

The human T-cell receptor beta (*TRB*, formerly known as *TCRB*) gene locus on chromosome 7 (7q34, formerly 7q35) includes 64–67 variable ( $V\beta$ ) gene segments (belonging to 30 subgroups), 2 diversity ( $D\beta$ ) gene segments, and 13 joining ( $J\beta$ ) gene segments, spread over 685 kilobases. The diversity of this locus has complicated PCR-based testing, however, this standardized multiplex PCR assay detects the vast majority of clonal *TRB* gene rearrangements using only three multiplex master mixes. The detection rate of clonal *TRB* gene rearrangements using this assay is exceptionally high.<sup>1</sup>

**Figure Legend:** Simplified diagram of a representative rearranged T-cell receptor beta gene and the T-cell receptor gamma gene showing the approximate placement of the upstream and downstream DNA primers. The numbers of primers and their specificity are listed for master mix *TCRB* Tubes A, B, and C and *TCRG* Tubes A and B. (The *Vy1f* primer is a consensus primer that targets *Vy1* through *Vy8*).

The T-cell receptor gamma (*TRG*, formerly known as *TCRG*) chain locus spans 128 kb on chromosome 7 (7p14). Rearrangement of the variable ( $V\gamma$ ) and joining ( $J\gamma$ ) genetic segments of the *TRG* locus result in  $V\gamma$ - $J\gamma$  products of unique length and sequence. The *TRG* locus does not contain D segments.<sup>2</sup> In addition, the *TRG* gene contains a limited number of  $V\gamma$  and  $J\gamma$  segments such that the amplification of all major  $V\gamma$ - $J\gamma$  combinations is possible with four  $V\gamma$  and two  $J\gamma$  primers. This standardized multiplex PCR assay detects the vast majority of clonal *TRG* gene rearrangements using two multiplex master mixes.<sup>3</sup> Using this assay, the clonal *TRG* gene rearrangement detection rate is exceptionally high.<sup>3</sup>

PCR products generated from the *TRB* and *TRG* assays are easily and reliably identified by heteroduplex analysis or capillary electrophoresis.

### Specimen Requirements

- 5 mL of peripheral blood, bone marrow biopsy, or bone marrow aspirate anti-coagulated with heparin or EDTA; or,
- Minimum 5 mm cube of tissue; or,
- 3  $\mu$ g of genomic DNA; or,
- Formalin-fixed, paraffin-embedded (FFPE) tissue or slides.

### Reference

1. M Brüggemann et al., *Leukemia* 17: 2283–2289 (2003).
2. JJM van Dongen et al., *Leukemia* 17: 2257–2317 (2003).
3. K Beldjord et al., *Leukemia* 17: 2289–2292 (2003).



This assay is based on the EuroClonality/BIOMED-2 Concerted Action BMH4-CT98-3936.

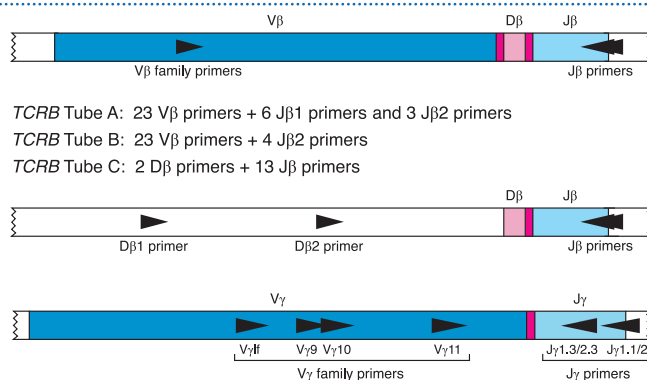

*TCRB* Tube A: 23  $V\beta$  primers + 6  $J\beta$ 1 primers and 3  $J\beta$ 2 primers  
*TCRB* Tube B: 23  $V\beta$  primers + 4  $J\beta$ 2 primers  
*TCRB* Tube C: 2  $D\beta$  primers + 13  $J\beta$  primers

*TCRG* tube A:  $V\gamma$ 1f and  $V\gamma$ 10 primers +  $J\gamma$ 1.1/2.1 and  $J\gamma$ 1.3/2.3  
*TCRG* tube B:  $V\gamma$ 9 and  $V\gamma$ 11 primers +  $J\gamma$ 1.1/2.1 and  $J\gamma$ 1.3/2.3



# Gel and Capillary

TCRB + TCRG T-Cell Clonality Assays

Research Use Only (RUO) Assay

## Reagents

Controls	Concentration	Units in Assay	Units in Assay MegaKit
IVS-0009 Clonal Control DNA	200 µg/mL	1 x 100 µL tube	5 x 100 µL tubes
IVS-0004 Clonal Control DNA	200 µg/mL	1 x 100 µL tube	5 x 100 µL tubes
IVS-0021 Clonal Control DNA	200 µg/mL	1 x 100 µL tube	5 x 100 µL tubes
IVS-0000 Polyclonal Control DNA	200 µg/mL	1 x 100 µL tube	5 x 100 µL tubes
Master Mixes	Target	Units in Assay	Units in Assay MegaKit
TCRB Tube A	Multiple Vβ + Jβ1/2	1 x 1500 µL tube	10 x 1500 µL tubes
TCRB Tube B	Multiple Vβ + Jβ2	1 x 1500 µL tube	10 x 1500 µL tubes
TCRB Tube C	Multiple Dβ + Jβ1/2	1 x 1500 µL tube	10 x 1500 µL tubes
TCRG Tube A	Vγ1-8 + Vγ10 + Jγ	1 x 1500 µL tube	10 x 1500 µL tubes
TCRG Tube B	Vγ9+ Vγ11 + Jγ	1 x 1500 µL tube	10 x 1500 µL tubes
Specimen Control Size Ladder	Multiple Genes	1 x 1500 µL tube	10 x 1500 µL tubes

## Gel Electrophoresis Detection

The data shown was generated using the master mix indicated. Amplified products were heteroduplexed and run on a 6% non-denaturing polyacrylamide/TBE gel. Lane 1 is data generated testing an alternative 100% clonal control DNA; lane 2 is data generated testing the recommended 100% clonal control DNA; lane 3 is data generated testing a 10% dilution of the recommended clonal control DNA; and, lane 4 is data generated testing IVS-0000 Polyclonal Control DNA (Cat# 4-092-0010). The IVS-0000 control is used as a negative control for many of our tests. A standard 100 base pair DNA size ladder was run in the lanes flanking the test samples.

### TCRB Tube A

Lane 1 = 100% IVS-0004  
Lane 2 = 100% IVS-0009  
Lane 3 = 10% IVS-0009  
Lane 4 = 100% IVS-0000

Valid Size Range =  $\rightarrow$   
240-285 bp  $\leftarrow$

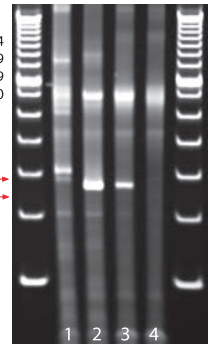

## Capillary Electrophoresis Detection (ABI)

The data shown was generated using the master mix indicated. Amplified products were run on an ABI 3100 instrument. Panel 1 displays data generated testing an alternative 100% clonal control DNA; panel 2 displays data generated testing the recommended 100% clonal control DNA; panel 3 displays data generated testing a 10% dilution of the recommended clonal control DNA; and, panel 4 displays data generated testing the IVS-0000 Polyclonal Control DNA (Cat# 4-092-0010). Our IVS-0000 DNA is often tested to provide information regarding valid size ranges for the master mix.

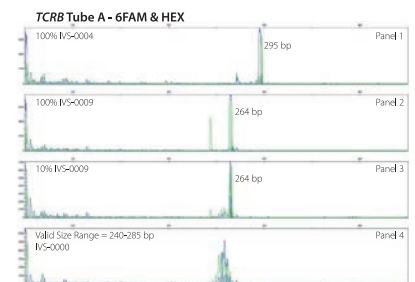

## Ordering Information

Catalog #	Products	Quantity
1-200-0010	TCRB + TCRG T-Cell Clonality Assay - Gel Detection	33 reactions
1-200-0020	TCRB + TCRG T-Cell Clonality Assay MegaKit - Gel Detection	330 reactions
1-200-0011	TCRB + TCRG T-Cell Clonality Assay - ABI Fluorescence Detection	33 reactions
1-200-0021	TCRB + TCRG T-Cell Clonality Assay MegaKit - ABI Fluorescence Detection	330 reactions

## TCRB Gene Clonality Assays

### Assay Use

TCRB Gene Clonality Assays are useful for studies involving:

- Identification clonal T-cell populations highly suggestive of T-cell malignancies
- Lineage determination of leukemias and lymphomas
- Monitoring and evaluation of disease recurrence
- Detection and assessment of residual disease
- Evaluation of new research and methods in malignancy studies

### Summary and Explanation of the Test

Three multiplex master mixes target conserved regions within the variable ( $V\beta$ ), diversity ( $D\beta$ ), and the joining ( $J\beta$ ) regions that flank the unique hypervariable, antigen-binding, complementarity determining region 3 (CDR3) of the T-cell receptor beta locus. Tube A contains 23  $V\beta$  primers, six  $J\beta 1$  primers, and three  $J\beta 2$  primers. Tube B contains 23  $V\beta$  and four  $J\beta 2$  primers. Tube C contains two  $D\beta$  and 13  $J\beta$  primers. Positive and negative DNA controls, as well as a Specimen Control Size Ladder Master Mix, are included. PCR products can be analyzed by capillary electrophoresis or heteroduplex analysis. Clonality is indicated, if any one of the master mixes generates clonal products.

### Background

The human T-cell receptor beta ( $TRB$ , formerly known as  $TCRB$ ) gene locus on chromosome 7 (7q34, formerly 7q35) includes 64-67 variable ( $V\beta$ ) gene segments (belonging to 30 subgroups), two diversity ( $D\beta$ ) gene segments, and 13 joining ( $J\beta$ ) gene segments, spread over 685 kilobases. The diversity of this locus has complicated PCR-based testing and extended dependence on Southern blot analysis in many testing centers. However, this standardized multiplex PCR assay detects the vast majority of clonal  $TRB$  gene rearrangements using only three multiplex master mixes.<sup>1</sup>

This assay provides rapid  $TCR$  clonality assessment, reducing or completely eliminating the number of Southern blot tests performed in the laboratory. The detection rate of clonal  $TRB$  gene rearrangements using this assay is exceptionally high.<sup>1</sup>

### Specimen Requirements

- 5 mL of peripheral blood, bone marrow biopsy, or bone marrow aspirate anti-coagulated with heparin or EDTA; or,
- Minimum 5 mm cube of tissue; or,
- 2  $\mu$ g of genomic DNA; or,
- Formalin-fixed, paraffin-embedded (FFPE) tissue or slides.

### Reference

1. M Brüggemann et al., *Leukemia* 17: 2283-2289 (2003).
2. JJM van Dongen et al., *Leukemia* 17: 2257-2317 (2003).



This assay is based on the EuroClonality/BIOMED-2 Concerted Action BMH4-CT98-3936.

**Figure Legend:** Simplified diagram of a representative rearranged T-cell receptor beta gene showing the approximate placement of the upstream and downstream DNA primers. The numbers of primers and their specificity are listed for Master Mix Tubes A, B, and C.



Tube A: 23  $V\beta$  primers + 6  $J\beta 1$  primers and 3  $J\beta 2$  primers

Tube B: 23  $V\beta$  primers + 4  $J\beta 2$  primers

Tube C: 2  $D\beta$  primers + 13  $J\beta$  primers

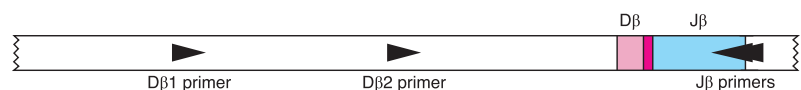

## Reagents

Controls	Concentration	Units in Assay	Units in Assay MegaKit
IVS-0009 Clonal Control DNA	200 µg/mL	1 x 100 µL tube	5 x 100 µL tubes
IVS-0004 Clonal Control DNA	200 µg/mL	1 x 100 µL tube	5 x 100 µL tubes
IVS-0021 Clonal Control DNA	200 µg/mL	1 x 100 µL tube	5 x 100 µL tubes
IVS-0000 Polyclonal Control DNA	200 µg/mL	1 x 100 µL tube	5 x 100 µL tubes
Master Mixes	Target	Units in Assay	Units in Assay MegaKit
TCRB Tube A	Multiple Vβ + Jβ1/2	1 x 1500 µL tube	10 x 1500 µL tubes
TCRB Tube B	Multiple Vβ + Jβ2	1 x 1500 µL tube	10 x 1500 µL tubes
TCRB Tube C	Multiple Dβ + Jβ1/2	1 x 1500 µL tube	10 x 1500 µL tubes

## Gel Electrophoresis Detection

The data shown was generated using the master mix indicated. Amplified products were heteroduplexed and run on a 6% non-denaturing polyacrylamide/TBE gel. Lane 1 is data generated testing an alternative 100% clonal control DNA; lane 2 is data generated testing the recommended 100% clonal control DNA; lane 3 is data generated testing a 10% dilution of the recommended clonal control DNA; and, lane 4 is data generated testing IVS-0000 Polyclonal Control DNA (Cat# 4-092-0010). The IVS-0000 control is used as a negative control for many of our tests. A standard 100 base pair DNA size ladder was run in the lanes flanking the test samples.

### TCRB Tube A

Lane 1 = 100% IVS-0004  
Lane 2 = 100% IVS-0009  
Lane 3 = 10% IVS-0009  
Lane 4 = 100% IVS-0000

Valid Size Range =  $\leftarrow$   
240-285 bp  $\rightarrow$

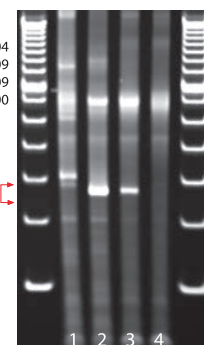

## Capillary Electrophoresis Detection (ABI)

The data shown was generated using the master mix indicated. Amplified products were run on an ABI 3100 instrument. Panel 1 displays data generated testing an alternative 100% clonal control DNA; panel 2 displays data generated testing the recommended 100% clonal control DNA; panel 3 displays data generated testing a 10% dilution of the recommended clonal control DNA; and, panel 4 displays data generated testing the IVS-0000 Polyclonal Control DNA (Cat# 4-092-0010). Our IVS-0000 DNA is often tested to provide information regarding valid size ranges for each master mix.

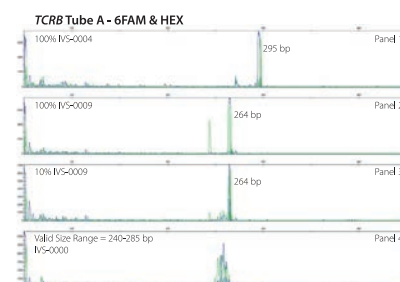

## Ordering Information

Catalog #	Products	Quantity
1-205-0010	TCRB Gene Clonality Assay - Gel Detection	33 reactions
1-205-0020	TCRB Gene Clonality Assay MegaKit - Gel Detection	330 reactions
1-205-0011	TCRB Gene Clonality Assay - ABI Fluorescence Detection	33 reactions
1-205-0021	TCRB Gene Clonality Assay MegaKit - ABI Fluorescence Detection	330 reactions

# Gel and Capillary

T-Cell Receptor Gamma Gene  
Rearrangement Assay 2.0

Research Use Only (RUO) Assay

## T-Cell Receptor Gamma Gene Rearrangement Assay 2.0

### Assay Use

T-Cell Receptor Gamma Gene Rearrangement Assays are useful for studies involving:

- Identification of clonal T-cell populations highly suggestive of T-cell malignancies
- Monitoring and evaluation of disease recurrence
- Evaluation of new research and methods in malignancy studies

### Summary and Explanation of the Test

This T-Cell Receptor Gamma Gene Rearrangement Assay 2.0 represents an improved approach to PCR-based clonality testing of lymphoproliferative disorders, as it can detect the vast majority of *TCR* gamma gene rearrangements with a single multiplex master mix. Importantly, this assay includes, in a single tube, primers for all known groups of *TCR* gamma variable (*V $\gamma$* ) region genes and joining (*J $\gamma$* ) region genes that are involved in rearrangements of T-cell lymphomas. In addition, all reverse primers that target the *J $\gamma$*  region genes are conjugated with the 6FAM fluorophore. Positive and negative controls, as well as a Specimen Control Size Ladder Master Mix are included. PCR products are analyzed by capillary electrophoresis.

### Background

The human T-cell receptor gamma (*TRG*, formerly known as *TCRG*) gene locus on chromosome 7 (7q14) includes 14 *V $\gamma$*  genes belonging to four subgroups, five *J $\gamma$*  segments, and two *C $\gamma$*  genes spread over 200 kilobases. The diversity of this locus has historically complicated PCR-based testing. Our new multiplex PCR assay represents an improvement over existing assays as it can detect the vast majority of *TCR* gamma gene rearrangements with a single multiplex master mix. This master mix targets all conserved regions within the variable (*V $\gamma$* ) and joining (*J $\gamma$* ) region genes that are described in lymphoid

malignancies. This is critical for more comprehensive analysis of patient samples, as some T-cell lymphoproliferative disorders involve *V $\gamma$*  and *J $\gamma$*  regions that would not be identified with a single *V $\gamma$* (1-8) and *J $\gamma$* 1/*J $\gamma$* 2 primer set.

In addition, the polyclonal background that results from the combination of all primers in a single tube produces a more robust and easily interpreted signal with capillary electrophoresis, which aids in the interpretation of small peaks. Competitive amplification of all *TRG* gene rearrangements allows for identification of a quantitative threshold for a positive result and helps to avoid false positive results. The average size of the *TRG* gene rearrangement PCR amplicons is 190 nucleotides, with a normal distribution of product sizes between 159 and 207 nucleotides. This protocol should lead to improved product formation from formalin-fixed, paraffin-embedded (FFPE) samples compared to other protocols that yield products of 260 nucleotides or larger.

### Specimen Requirements

- 5 mL of peripheral blood, bone marrow biopsy, or bone marrow aspirate anti-coagulated with heparin or EDTA; or,
- Minimum 5 mm cube of tissue; or,
- 2  $\mu$ g of genomic DNA; or,
- Formalin-fixed, paraffin-embedded tissue or slides.

### Reference

1. TC Greiner et al., *JMD* 4: 137-143 (2002).
2. LC Lawnickie et al., *JMD* 5: 82-87 (2003).
3. Y Sandberg et al., *Leukemia* 21: 21 (2007).
4. Armand, Marine et al. *HemaSphere*, 2019;3:3.



This assay was developed by Invivoscribe.

The performance of this assay was reviewed and validated by the EuroClonality/BIOMED-2 Group.<sup>4</sup>

**Figure Legend:** Simple representation of the organization of the T-cell receptor gamma gene on chromosome 7. Black arrows represent the relative positions of primers that target the variable region genes and the downstream joining region gene segments that are involved in rearrangements in T-cell lymphomas. The downstream primers are fluorescently labeled through the incorporation of a 6FAM fluorophore. The amplicon products generated from these rearrangements are detected by capillary electrophoresis.

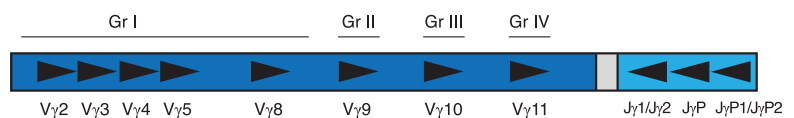

# Gel and Capillary

T-Cell Receptor Gamma Gene  
Rearrangement Assay 2.0

Research Use Only (RUO) Assay

## Reagents

Controls	Concentration	Units in Assay	Units in Assay MegaKit
5% <i>TCRG</i> Positive Control DNA	50 µg/mL	1 x 50 µL tube	5 x 50 µL tube
<i>TCRG</i> Negative Control DNA	50 µg/mL	1 x 50 µL tube	5 x 50 µL tube
Master Mixes	Target	Units in Assay	Units in Assay MegaKit
<i>TCRG</i> - 6FAM	Vy1-Vy11 + Jy1/Jy2, JyP, JyP1/JyP2	1 x 1500 µL tube	10 x 1500 µL tubes
Specimen Control Size Ladder	Multiple Genes	1 x 1500 µL tube	10 x 1500 µL tubes

## Capillary Electrophoresis Detection (ABI)

The data shown was generated using the *TCRG*-6FAM master mix. Amplified products were run on a capillary electrophoresis ABI 3130xl instrument. Panel 1 displays data generated testing 100% *TCRG* Positive Control DNA (DNA isolated from a cell line known to have both a Vy9 + Jy1/Jy2 and a Vy10 + Jy1/Jy2 rearrangement); panel 2 displays data generated from the testing of the 5% *TCRG* Positive Control DNA; and, panel 3 displays data generated from the testing of the polyclonal *TCRG* Negative Control DNA.

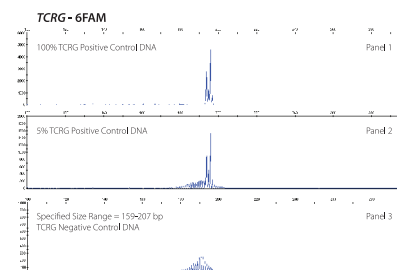

## Ordering Information

Catalog #	Products	Quantity
1-207-0101	T-Cell Receptor Gamma Gene Rearrangement Assay 2.0 - ABI Fluorescence Detection	33 reactions
1-207-0111	T-Cell Receptor Gamma Gene Rearrangement Assay MegaKit 2.0 - ABI Fluorescence Detection	330 reactions

# Gel and Capillary

T-Cell Receptor Gamma Gene  
Rearrangement Assays

Research Use Only (RUO) Assay

## T-Cell Receptor Gamma Gene Rearrangement Assays

### Assay Use

T-Cell Receptor Gamma Gene Rearrangement Assays are useful for studies involving:

- Identification of clonal T-cell populations highly suggestive of T-cell malignancies
- Lineage determination of leukemias and lymphomas
- Monitoring and evaluation of disease recurrence
- Detection and assessment of residual disease
- Evaluation of new research and methods in malignancy studies

### Summary and Explanation of the Test

Sample genomic DNA is amplified using two master mixes that independently target conserved regions within the variable ( $V\gamma$ ) and joining ( $J\gamma$ ) regions that flank the unique, hypervariable, antigen-binding, complementarity determining region 3 (CDR3). This assay targets  $V\gamma 1-9$  and  $J\gamma$  gene segments. Positive and negative DNA controls, as well as an internal Amplification Control Master Mix, are included. The limit of detection of this assay is approximately one clonal T cell in a background of a hundred normal cells. PCR products can be analyzed by capillary electrophoresis or standard gel electrophoresis with ethidium bromide staining.

### Background

The T-cell receptor gamma ( $TRG$ , formerly known as  $TCRG$ ) chain locus spans 160 kilobases on chromosome 7 (7p14). The locus consists of 14 variable ( $V\gamma$ ) gene segments in six subgroups, and five joining ( $J\gamma$ ) gene segments interspersed between two constant ( $C\gamma$ ) gene segments. However, the repertoire of functional  $TRG$  molecules is limited to 4-6 functional  $V\gamma$  gene segments that belong to two subgroups.<sup>2</sup>

Rearrangement of the  $V\gamma$  and  $J\gamma$  gene segments of the  $TRG$  locus results in  $V\gamma$ - $J\gamma$  products of unique length and sequence. Clonal  $TRG$  rearrangements can be most rapidly identified by analyzing the size distribution of DNA products amplified from conserved sequences that flank this  $V\gamma$ - $J\gamma$  region.<sup>1</sup> DNA isolated from a normal heterogeneous population of polyclonal T-cells produces a Gaussian distribution (bell-shaped size curve) of amplified products. DNA amplified from a clonal T-cell population generates one or two product(s) of unique size that reflects proliferation of a single rearranged clone.<sup>1,2</sup>

### Specimen Requirements

- 5 mL of peripheral blood, bone marrow biopsy, or bone marrow aspirate anti-coagulated with heparin or EDTA; or,
- Minimum 5 mm cube of tissue; or,
- 2  $\mu$ g of genomic DNA; or,
- Formalin-fixed, paraffin-embedded (FFPE) tissue or slides.

### Reference

1. JE Miller, SS Wilson, DL Jaye, and M Kronenberg. *J. Mol. Diag.* 4: 101-117 (1999).
2. K Beldjord et al., *Leukemia* 17: 2289-2292 (2003).

**Figure Legend:** Simplified figure representing the organization of a rearranged T-cell receptor gamma chain gene on chromosome 7. Colored arrows represent conserved regions within the variable region gene segments targeted by primers. Primers are represented by arrows with the size range of valid products generated with each of the master mixes indicated below the figure. Colors correspond to the peak colors assigned to products when differential fluorescence detection methods are used.

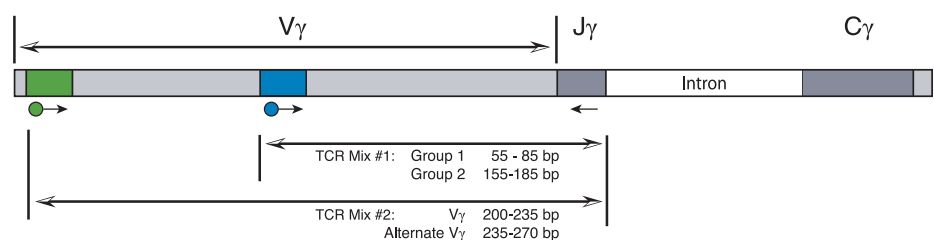

# Gel and Capillary

T-Cell Receptor Gamma Gene  
Rearrangement Assays

Research Use Only (RUO) Assay

## Reagents

Controls	Concentration	Units in Assay	Units in Assay MegaKit
IVS-0009 Clonal Control DNA	200 µg/mL	1 x 100 µL tube	5 x 100 µL tubes
IVS-0000 Polyclonal Control DNA	200 µg/mL	1 x 100 µL tube	5 x 100 µL tubes
Master Mixes	Target	Units in Assay	Units in Assay MegaKit
T-Cell Receptor Gamma Mix 1	Vγ1-8,9 + Jγ1/2	1 x 1500 µL tube	10 x 1500 µL tubes
T-Cell Receptor Gamma Mix 2	Alt Vγ + Jγ1/2	1 x 1500 µL tube	10 x 1500 µL tubes
Amplification Control	HLA-DQα	1 x 1500 µL tube	10 x 1500 µL tubes

## Gel Electrophoresis Detection

The data shown was generated using the master mix indicated. Amplified products were run on a 6% non-denaturing polyacrylamide/TBE gel. Lane 1 is data generated testing an alternative 100% clonal control DNA; lane 2 is data generated testing the recommended 100% clonal control DNA; lane 3 is data generated testing a 10% dilution of the recommended clonal control DNA; and, lane 4 is data generated testing IVS-0000 Polyclonal Control DNA (Cat# 4-092-0010). The IVS-0000 control is used as a negative control for many of our tests. A standard 100 base pair DNA size ladder was run in the lanes flanking the test samples.

### T Cell Receptor Gamma Mix 1

Lane 1 = 100% IVS-0021  
Lane 2 = 100% IVS-0009  
Lane 3 = 10% IVS-0009  
Lane 4 = 100% IVS-0000

Valid Size Range =  
55-85 bp  
& 155-185 bp

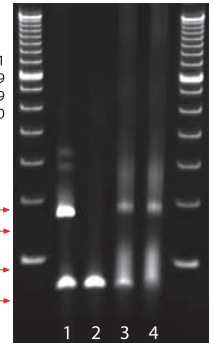

## Capillary Electrophoresis Detection (ABI)

The data shown was generated using the master mix indicated. Amplified products were run on an ABI 3100 instrument. Panel 1 displays data generated testing an alternative 100% clonal control DNA; panel 2 displays data generated testing the recommended 100% clonal control DNA; panel 3 displays data generated testing a 10% dilution of the recommended clonal control DNA; and, panel 4 displays data generated testing the IVS-0000 Polyclonal Control DNA (Cat# 4-092-0010). Our IVS-0000 DNA is often tested to provide information regarding valid size ranges for each master mix.

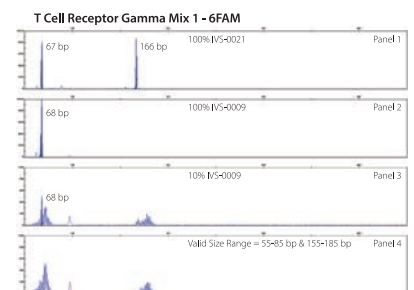

## Ordering Information

Catalog #	Products	Quantity
1-207-0010	T-Cell Receptor Gene Rearrangement Assay - Gel Detection	30 reactions
1-207-0030	T-Cell Receptor Gene Rearrangement Assay MegaKit - Gel Detection	300 reactions
1-207-0051	T-Cell Receptor Gene Rearrangement Assay - ABI Fluorescence Detection	30 reactions
1-207-0071	T-Cell Receptor Gene Rearrangement Assay MegaKit - ABI Fluorescence Detection	300 reactions

## TCRG Gene Clonality Assays

### Assay Use

TCRG Gene Clonality Assays are useful for studies involving:

- Identification of clonal T-cell populations highly suggestive of T-cell malignancies
- Lineage determination of leukemias and lymphomas
- Monitoring and evaluation of disease recurrence
- Detection and assessment of residual disease
- Evaluation of new research and methods in malignancy studies

### Summary and Explanation of the Test

This assay tests all variable ( $V\gamma$ ) regions 1–11 of the *TRG* (formerly known as *TCRG*) gene. Master mix tubes A and B target conserved regions within the variable ( $V\gamma$ ) and joining ( $J\gamma$ ) regions that flank the unique, hypervariable, antigen-binding, complementarity determining region 3 (CDR3). Tube A contains two  $V\gamma$  primers and two  $J\gamma$  primers. Tube B contains two  $V\gamma$  primers and two  $J\gamma$  primers. Positive and negative controls, as well as a Specimen Control Size Ladder Master Mix are included. PCR products can be analyzed by capillary electrophoresis or heteroduplex analysis. Clonality is indicated if any one of the master mixes generates clonal products.

### Background

The T-cell receptor gamma (*TRG*, formerly known as *TCRG*) chain locus spans 128 kb on chromosome 7 (7p14). Rearrangement of the variable ( $V\gamma$ ) and joining ( $J\gamma$ ) genetic segments of the *TRG* locus result in  $V\gamma$ - $J\gamma$  products of unique length and sequence. The *TRG* locus does not contain diversity ( $D\gamma$ ) segments.<sup>2</sup> *TRG* is a preferential target for clonality analyses since it is rearranged in greater than 90% of T-ALL, T-large granular lymphocyte (LGL), and T-PLL, in 50–75% of peripheral T-NHL and mycosis fungoides, but not NK cell proliferations. It is also rearranged in a major part (60%) of B-lineage ALLs and in a much

smaller part of B NHLs. In addition, the *TRG* gene contains a limited number of  $V\gamma$  and  $J\gamma$  segments such that the amplification of all major  $V\gamma$ - $J\gamma$  combinations is possible with four  $V\gamma$  and two  $J\gamma$  primers.

This standardized multiplex PCR assay detects the vast majority of clonal *TRG* gene rearrangements using only two multiplex master mixes.<sup>1</sup> The potential risk of false-positive results, due to overinterpretation of minor clonal peaks, can be minimized by the combined use of heteroduplex analysis and differential fluorescence detection, and by interpreting results within their clinical context.<sup>1,2</sup>

The detection rate of clonal *TRG* gene rearrangements using this assay is exceptionally high.<sup>1</sup>

### Specimen Requirements

- 5 mL of peripheral blood, bone marrow biopsy, or bone marrow aspirate anti-coagulated with heparin or EDTA; or,
- Minimum 5 mm cube of tissue; or,
- 2  $\mu$ g of genomic DNA; or,
- Formalin-fixed, paraffin-embedded (FFPE) tissue or slides.

### Reference

1. K Beldjord et al., *Leukemia* 17: 2289–2292 (2003).
2. JJM van Dongen et al., *Leukemia* 17: 2257–2317 (2003).



This assay is based on the EuroClonality/BIOMED-2 Concerted Action BMH4-CT98-3936.

**Figure Legend:** Depicted is a simple representation of the organization of the T-cell receptor gamma chain gene on chromosome 7. Black arrows represent the relative positions of primers that target the variable ( $V\gamma$ ) regions, and the downstream joining ( $J\gamma$ ) gene segments. The amplicon products generated from each of these regions can be differentially detected when fluorescent primer sets are used with capillary electrophoresis instruments that employ differential fluorescence detection.

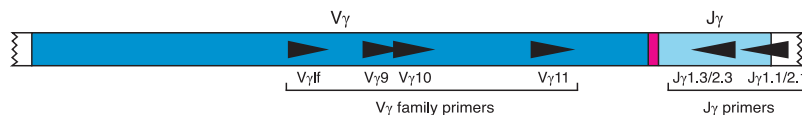

TCRG tube A:  $V\gamma 1f$  and  $V\gamma 10$  primers +  $J\gamma 1.1/2.1$  and  $J\gamma 1.3/2.3$

TCRG tube B:  $V\gamma 9$  and  $V\gamma 11$  primers +  $J\gamma 1.1/2.1$  and  $J\gamma 1.3/2.3$



## Reagents

Controls	Concentration	Units in Assay	Units in Assay MegaKit
IVS-0009 Clonal Control DNA	200 µg/mL	1 x 100 µL tube	5 x 100 µL tubes
IVS-0021 Clonal Control DNA	200 µg/mL	1 x 100 µL tube	5 x 100 µL tubes
IVS-0000 Polyclonal Control DNA	200 µg/mL	1 x 100 µL tube	5 x 100 µL tubes
Master Mixes	Target	Units in Assay	Units in Assay MegaKit
TCRG Tube A	Vy1-8 + Vy10 + Jy	1 x 1500 µL tube	10 x 1500 µL tubes
TCRG Tube B	Vy9 + Vy11 + Jy	1 x 1500 µL tube	10 x 1500 µL tubes
Specimen Control Size Ladder	Multiple Genes	1 x 1500 µL tube	10 x 1500 µL tubes

## Gel Electrophoresis Detection

The data shown was generated using the master mix indicated. Amplified products were heteroduplexed and run on a 6% non-denaturing polyacrylamide/TBE gel. Lane 1 is data generated testing an alternative 100% clonal control DNA; lane 2 is data generated testing the recommended 100% clonal control DNA; lane 3 is data generated testing a 10% dilution of the recommended clonal control DNA; and, lane 4 is data generated testing IVS-0000 Polyclonal Control DNA (Cat# 4-092-0010). The IVS-0000 control is used as a negative control for many of our tests. A standard 100 base pair DNA size ladder was run in the lanes flanking the test samples.

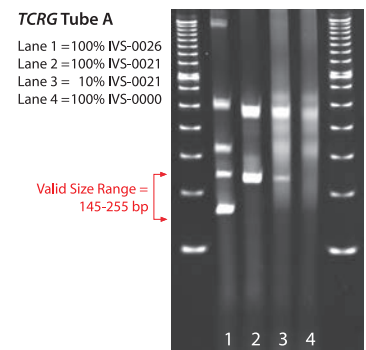

## Capillary Electrophoresis Detection (ABI)

The data shown was generated using the master mix indicated. Amplified products were run on an ABI 3100 instrument. Panel 1 displays data generated testing an alternative 100% clonal control DNA; panel 2 displays data generated testing the recommended 100% clonal control DNA; panel 3 displays data generated testing a 10% dilution of the recommended clonal control DNA; and, panel 4 displays data generated testing the IVS-0000 Polyclonal Control DNA (Cat# 4-092-0010). Our IVS-0000 DNA is often tested to provide information regarding valid size ranges for each master mix.

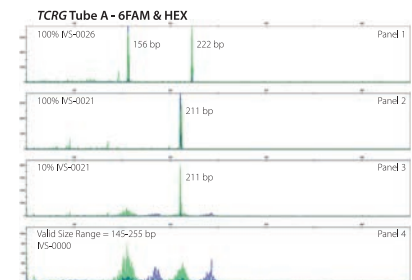

## Ordering Information

Catalog #	Products	Quantity
1-207-0020	TRG Gene Clonality Assay - Gel Detection	33 reactions
1-207-0040	TRG Gene Clonality Assay MegaKit - Gel Detection	330 reactions
1-207-0021	TRG Gene Clonality Assay - ABI Fluorescence Detection	33 reactions
1-207-0041	TRG Gene Clonality Assay MegaKit - ABI Fluorescence Detection	330 reactions

## TCRD Gene Clonality Assays

### Assay Use

TCRD Gene Clonality Assays are useful for studies involving:

- Identification of clonal T-cell populations highly suggestive of T-cell malignancies
- Lineage determination of leukemias and lymphomas
- Monitoring and evaluation of disease recurrence
- Detection and assessment of residual disease
- Evaluation of new research and methods in malignancy studies

### Summary and Explanation of the Test

The TCRD Tube Master Mix targets conserved regions within the variable (V $\delta$ 1-6), the diversity (D $\delta$ 2-3) and the joining (J $\delta$ 1-4) regions that flank the unique, hypervariable, antigen-binding, complementarity determining region 3 (CDR3) of the T-cell receptor delta (*TRD*, formerly known as *TCRD*). Positive and negative controls, as well as a Specimen Control Size Ladder Master Mix, are included. PCR products can be analyzed by capillary electrophoresis or heteroduplex analysis. Clonality is indicated if the master mix generates clonal products.

### Background

The human T-cell receptor delta (*TRD*, formerly known as *TCRD*) gene locus is comprised of a cluster of 10 genes located on chromosome 14 (14q11.2) spread over 60 kilobases, localized between the T-cell receptor alpha (*TRA*, formerly known as *TCRA*) variable (V $\alpha$ ) and joining (J $\alpha$ ) gene segments. It is made up of eight variable (V $\delta$ ), three diversity (D $\delta$ ), and four joining (J $\delta$ ) gene segments.<sup>1</sup> At least five of the eight V $\delta$  gene segments can also rearrange to J $\delta$  gene segments and other V $\delta$  gene segments may also be utilized in *TRD* gene rearrangements in rare cases. Although the small number of V $\delta$ , D $\delta$ , and J $\delta$  gene segments available for recombination limits the

potential combinatorial diversity, the complementarity determining region 3 (CDR3) or junctional diversity is extensive due to the addition of N regions, P regions, and random deletion of nucleotides by recombinases. This diversity is also extended by the recombination of up to three D $\delta$  segments and therefore up to four N regions within the rearranged *TRD* locus. This limited germline diversity encoded at the *TRD* locus in conjunction with extensive junctional diversity results in a useful target for PCR analysis. *TRD* recombination events have been used most extensively as clonal markers in both T- and B-cell ALL. This standardized multiplex PCR assay detects the vast majority of clonal *TRD* gene rearrangements using a single multiplex master mix<sup>1</sup>. This assay provides rapid *TCR* clonality assessment, reducing or eliminating the number of Southern blot tests performed in the laboratory.<sup>2</sup> The detection rate of clonal *TRD* gene rearrangements using this assay is exceptionally high.<sup>1</sup>

### Specimen Requirements

- 5 mL of peripheral blood, bone marrow biopsy, or bone marrow aspirate anti-coagulated with heparin or EDTA; or,
- Minimum 5 mm cube of tissue; or,
- 2  $\mu$ g of genomic DNA; or,
- Formalin-fixed, paraffin-embedded (FFPE) tissue or slides.

### Reference

1. FL Lavender et al., *Leukemia* 17: 2292-2296 (2003).
2. JJM van Dongen et al., *Leukemia* 17: 2257-2317 (2003).



This assay is based on the EuroClonality/BIOMED-2 Concerted Action BMH4-CT98-3936.

**Figure Legend:** Simplified diagram of a representative rearranged T-cell receptor delta gene showing the approximate placement of the upstream and downstream DNA primers. The numbers of primers and their specificity are listed for the *TRD* Tube Master Mix tube.

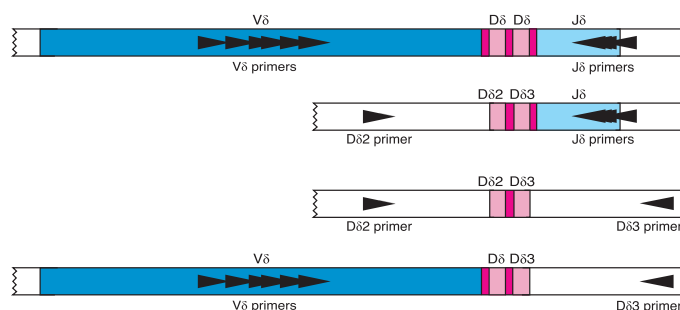

TCRD tube: 6 V $\delta$  and 1 D $\delta$ 2 primers + 4 J $\delta$  and 1 D $\delta$ 3 primers

## Reagents

Controls	Concentration	Units in Assay	Units in Assay MegaKit
IVS-0021 Clonal Control DNA	200 µg/mL	1 x 100 µL tube	5 x 100 µL tubes
IVS-0000 Polyclonal Control DNA	200 µg/mL	1 x 100 µL tube	5 x 100 µL tubes
Master Mixes	Target	Units in Assay	Units in Assay MegaKit
TCRD Tube	Multiple Vδ + Dδ + Jδ	1 x 1500 µL tube	10 x 1500 µL tubes
Specimen Control Size Ladder	Multiple Genes	1 x 1500 µL tube	10 x 1500 µL tubes

## Gel Electrophoresis Detection

The data shown was generated using the master mix indicated. Amplified products were heteroduplexed and run on a 6% non-denaturing polyacrylamide/TBE gel. Lane 1 is data generated testing an alternative 100% clonal control DNA; lane 2 is data generated testing the recommended 100% clonal control DNA; lane 3 is data generated testing a 10% dilution of the recommended clonal control DNA; and, lane 4 is data generated testing IVS-0000 Polyclonal Control DNA (Cat# 4-092-0010). The IVS-0000 control is used as a negative control for many of our tests. A standard 100 base pair DNA size ladder was run in the lanes flanking the test samples.

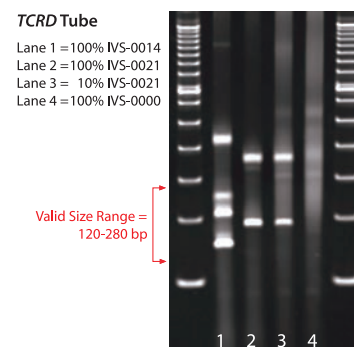

## Capillary Electrophoresis Detection (ABI)

The data shown was generated using the master mix indicated. Amplified products were run on an ABI 3100 instrument. Panel 1 displays data generated testing an alternative 100% clonal control DNA; panel 2 displays data generated testing the recommended 100% clonal control DNA; panel 3 displays data generated testing a 10% dilution of the recommended clonal control DNA; and, panel 4 displays data generated testing the IVS-0000 Polyclonal Control DNA (Cat# 4-092-0010). Our IVS-0000 DNA is often tested to provide information regarding valid size ranges for each master mix.

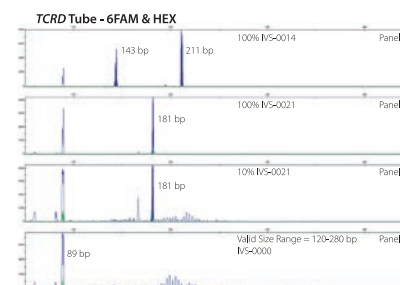

## Ordering Information

Catalog #	Products	Quantity
1-206-0010	TCRD Gene Clonality Assay - Gel Detection	33 reactions
1-206-0020	TCRD Gene Clonality Assay MegaKit - Gel Detection	330 reactions
1-206-0011	TCRD Gene Clonality Assay - ABI Fluorescence Detection	33 reactions
1-206-0021	TCRD Gene Clonality Assay MegaKit - ABI Fluorescence Detection	330 reactions

## BCL1/JH Translocation Assay

### Assay Use

The *BCL1/JH* Translocation Assay is useful for studies involving:

- Identification of *IGH-BCL1* (now known as *IGH-CCND1*) gene rearrangements highly suggestive of mantle cell lymphoma
- Lineage determination of leukemias and lymphomas
- Monitoring and evaluation of disease recurrence
- Detection and assessment of residual disease
- Evaluation of new research and methods in malignancy studies

### Summary and Explanation of the Test

Two master mixes are included in this assay kit. The *BCL1/JH* Master Mix targets the major translocation cluster (MTC) of the *CCND1* locus (formerly known as *BCL1*) and the joining region (JH) of the immunoglobulin heavy chain locus (IGH). The Specimen Control Size Ladder Master Mix targets multiple genes and generates a series of amplicons of approximately 100, 200, 300, 400, and 600 base pairs to ensure that the quality and quantity of input DNA is adequate to yield a valid result. Positive and negative controls are included. PCR products can be analyzed using standard gel electrophoresis with ethidium bromide staining. A *CCND1* translocation is indicated if the master mix generates product(s) within the valid size range.

### Background

The *IGH-CCND1* t(11;14)(q13;q32) translocation is mainly found in mantle cell lymphomas, but has also been seen in B-prolymphocytic leukemia (10-20%), plasma cell leukemia, splenic lymphoma with villous lymphocytes, chronic lymphocytic leukemia (2-5%), and in

multiple myeloma (20-25%). The t(11;14) brings about juxtaposition of the cyclin D1 gene with the immunoglobulin heavy chain gene. This leads to a marked increase in expression of cyclin D1 driven by the Ig heavy chain gene enhancer, located in the intron between the JH and constant region genes. The overexpression of cyclin D1 accelerates the passage of transformed cells through the G1 phase. Approximately 41% of the breakpoints on the *CCND1/MTC* locus can be detected by PCR methodology. However, breakpoints outside of the *CCND1/MTC* locus will not be identified by this particular test. Therefore, a negative result does not completely exclude the presence of an *IGH-CCND1* gene translocation in the sample.<sup>1</sup>

### Specimen Requirements

- 5 mL of peripheral blood, bone marrow biopsy, or bone marrow aspirate anti-coagulated with heparin or EDTA; or,
- Minimum 5 mm cube of tissue; or,
- 2 µg of genomic DNA; or,
- Formalin-fixed, paraffin-embedded (FFPE) tissue or slides.

### Reference

1. P Wijers et al., *Leukemia* 17: 2296-2298 (2003).
2. JJM van Dongen et al., *Leukemia* 17: 2257-2317 (2003).



This assay is based on the EuroClonality/BIOMED-2 Concerted Action BMH4-CT98-3936.

**Figure Legend:** Schematic diagram of the *IGH-CCND1* t(11;14) translocation showing the cyclin D1 (*CCND1*) gene on the left and the Ig heavy chain (*IGH*) gene on the right. Shown are the relative positions and orientations for the *BCL1/MTC* primer and the JH primer, which are included in the *BCL1/JH* Master Mix tube.

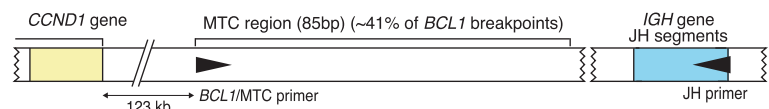

t(11;14) tube: 1 *BCL1* MTC primer + 1 JH primer

# Gel and Capillary

*BCL1/JH* Translocation Assay

Research Use Only (RUO) Assay

## Reagents

Controls	Concentration	Units in Assay	Units in Assay MegaKit
IVS-0010 Clonal Control DNA	200 µg/mL	1 x 100 µL tube	5 x 100 µL tubes
IVS-0000 Polyclonal Control DNA	200 µg/mL	1 x 100 µL tube	5 x 100 µL tubes
Master Mixes	Target	Units in Assay	Units in Assay MegaKit
<i>BCL1/JH</i> Tube	MTC of <i>CCND1 + IGH JH</i>	1 x 1500 µL tube	10 x 1500 µL tubes
Specimen Control Size Ladder	Multiple Genes	1 x 1500 µL tube	10 x 1500 µL tubes

## Agarose Gel Electrophoresis Detection

The data shown was generated using the master mix indicated. Amplified products were run on a 2% agarose/TBE gel. Lane 1 is data generated testing the recommended 100% clonal control DNA; lane 2 is data generated testing a 10% dilution of the recommended clonal control DNA; lane 3 is data generated testing a 1% dilution of the recommended clonal control DNA; lane 4 is data generated testing a 0.1% dilution of the recommended clonal control DNA; and, lane 5 is data generated testing IVS-0000 Polyclonal Control DNA (Cat# 4-092-0010). This control is used as a negative control for many of our tests. A standard 100 base pair DNA size ladder was run in the lanes flanking the test samples.

### *BCL1/JH* Tube

Lane 1 = 100% IVS-0010  
 Lane 2 = 10% IVS-0010  
 Lane 3 = 1% IVS-0010  
 Lane 4 = 0.1% IVS-0010  
 Lane 5 = 100% IVS-0000

Valid Size Range =  
 150-2000 bp

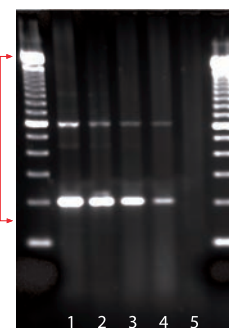

## Ordering Information

Catalog #	Products	Quantity
1-308-0010	<i>BCL1/JH</i> Translocation Assay - Gel Detection	33 reactions
1-308-0020	<i>BCL1/JH</i> Translocation Assay MegaKit - Gel Detection	330 reactions

## *BCL2/JH t(14;18) Translocation Assay*

### Assay Use

The *BCL2/JH t(14;18) Translocation Assay* is useful for studies involving:

- Monitoring and evaluation of follicular lymphomas and other B-cell lymphomas
- Distinguishing lymphoma from benign lymphoid hyperplasia
- Distinguishing follicular lymphoma from other B-cell lymphomas that may have a similar appearance
- Monitoring and evaluation of disease recurrence
- Detection and assessment of residual disease
- Evaluation of new research and methods in malignancy studies

### Summary and Explanation of the Test

Five master mixes are included in this assay kit. Two master mixes target *BCL2* major break point (MBR) translocations and two target *BCL2* minor cluster region (mcr) translocations. An Amplification Control Master Mix is also included to ensure the quality and quantity of sample DNA. Positive and negative controls are also included. This assay can be run either in a standard or nested assay format.

Using the standard method, the limit of detection is one cell in one hundred normal cells. The nested method has a limit of detection of one *t(14;18)* positive cell in a background of ten thousand normal cells. PCR products can be analyzed by standard gel electrophoresis with ethidium bromide staining. A *BCL2* translocation is indicated if just one of the 2<sup>nd</sup> round master mixes (mixes ending in b) generates product(s) within the valid size range.

### Background

The *IGH-BCL2 t(14;18)(q32;q21)* translocation is found in 80-90% of follicular lymphomas and in 30% of diffuse large cell lymphomas.<sup>1,2</sup> The translocation is rarely present in other lymphoproliferative diseases.<sup>2</sup> The *t(14;18)* brings about juxtaposition of *BCL2* with the Ig heavy chain joining segment. This leads to a marked increase in expression of *BCL2* driven by the Ig heavy chain gene enhancer.<sup>1</sup> The *BCL2* protein inhibits programmed cell death (apoptosis) leading to cell accumulation.<sup>2</sup> The majority of breakpoints on 18q21-22 occur within the major breakpoint region (MBR) in the 3' untranslated region of exon 3 (60-70% of the cases), and the minor cluster region (mcr) located 3' to *BCL2* exon 3 (20-25% of the cases).<sup>1</sup> Some breakpoints occur at distant loci and will not be identified by this particular test.<sup>2</sup> Therefore, a negative result does not completely exclude the presence of a *IGH-BCL2* gene rearrangement in the sample. In comparison, Southern blot analysis requires 1-2 weeks, is significantly less sensitive, and has more restrictive Specimen requirements.

### Specimen Requirements

- 5 mL of peripheral blood, bone marrow biopsy, or bone marrow aspirate anti-coagulated with heparin or EDTA; or,
- Minimum 5 mm cube of tissue; or,
- 3 µg of genomic DNA; or,
- Formalin-fixed, paraffin-embedded (FFPE) tissue or slides.

### Reference

1. MS Lee et al., *Science* 237: 175-178 (1987).
2. M Crescenzi et al., *Proc. Natl. Acad. Sci. USA* 85: 4869-4873 (1988).

**Figure Legend:** Simplified view of the genomic organization of the *BCL2* and *IGH* genes on chromosomes 18 and 14, respectively. Yellow boxes represent the exon regions of the *BCL2* gene. Exons of the immunoglobulin heavy chain gene are represented in other colors. The solid black lines represents intron regions, which have been left incompletely spliced to assist in demarcation of the exon segments. MBR and mcr type *t(14;18)* translocations are shown in the lower portions of the figure with the relative positions of primers and the size of the amplicons generated from the positive control DNAs indicated.

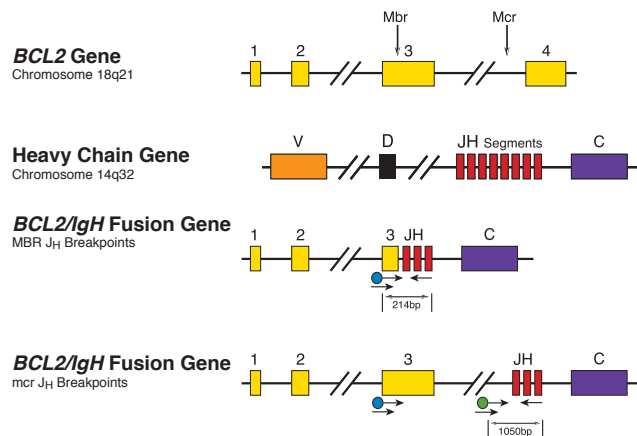

# Gel and Capillary

*BCL2/JH* t(14;18) Translocation Assay

Research Use Only (RUO) Assay

## Reagents

Controls	Concentration	Units in Assay	Units in Assay MegaKit
IVS-0030 Clonal Control DNA	200 µg/mL	1 x 100 µL tube	5 x 100 µL tubes
IVS-0031 Clonal Control DNA	200 µg/mL	1 x 100 µL tube	5 x 100 µL tubes
IVS-0009 Clonal Control DNA	200 µg/mL	1 x 100 µL tube	5 x 100 µL tubes
Master Mixes	Target	Units in Assay	Units in Assay MegaKit
<i>BCL2/JH</i> t(14;18) (MBR) Mix 1b	Inside <i>BCL2</i> MBR	1 x 1500 µL tube	10 x 1500 µL tubes
<i>BCL2/JH</i> t(14;18) (mcr) Mix 2b	Inside <i>BCL2</i> mcr	1 x 1500 µL tube	10 x 1500 µL tubes
<i>BCL2/JH</i> t(14;18) (MBR) Mix 1a	Outside <i>BCL2</i> MBR	1 x 1500 µL tube	10 x 1500 µL tubes
<i>BCL2/JH</i> t(14;18) (mcr) Mix 2a	Outside <i>BCL2</i> mcr	1 x 1500 µL tube	10 x 1500 µL tubes
Amplification Control	<i>HLA-DQα</i>	1 x 1500 µL tube	10 x 1500 µL tubes

## Gel Electrophoresis Detection

The data shown was generated using the master mix indicated. Amplified products were run on a 2% agarose/TBE gel. Lane 1 is data generated testing the recommended 100% clonal control DNA; lane 2 is data generated testing a 10% dilution of the recommended clonal control DNA; lane 3 is data generated testing a 1% dilution of the recommended clonal control DNA; lane 4 is data generated testing a 0.1% dilution of the recommended clonal control DNA; and, lane 5 is data generated testing IVS-0000 Polyclonal Control DNA (Cat# 4-092-0010). The IVS-0000 control is used as a negative control for many of our tests. A standard 100 base pairs DNA size ladder was run in the lanes flanking the test samples.

### *BCL2/JH* t(14;18) Mix 1b (Nested)

Lane 1 = 100% IVS-0030  
Lane 2 = 10% IVS-0030  
Lane 3 = 1% IVS-0030  
Lane 4 = 0.1% IVS-0030  
Lane 5 = 100% IVS-0000

Valid Size Range =  
80-300 bp

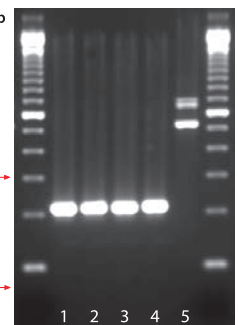

## Ordering Information

Catalog #	Products	Quantity
1-309-0010	<i>BCL2/JH</i> t(14;18) Translocation Assay - Gel Detection	30 reactions
1-309-0030	<i>BCL2/JH</i> t(14;18) Translocation Assay MegaKit - Gel Detection	300 reactions

## *BCL2/JH* Translocation Assay

### Assay Use

The *BCL2/JH* Translocation Assay is useful for studies involving:

- Monitoring and evaluation of follicular lymphomas and other B-cell lymphomas
- Distinguishing lymphoma from benign lymphoid hyperplasia
- Distinguishing follicular lymphoma from other B-cell lymphomas that may have a similar appearance
- Monitoring and evaluation of disease recurrence
- Detection and assessment of residual disease
- Evaluation of new research and methods in malignancy studies

The t(14;18) brings about juxtaposition of *BCL2* with the Ig heavy chain joining segment. This leads to a marked increase in expression of *BCL2* driven by the Ig heavy chain gene enhancer. The *BCL2* protein inhibits programmed cell death (apoptosis) leading to cell accumulation. The majority of breakpoints on 18q21-22 occur within the major breakpoint region (MBR) in the 3' untranslated region of exon 3 (60- 70% of the cases), and the minor cluster (mcr) region located 3' to *BCL2* exon 3 (20-25% of the cases). Some breakpoints occur at distant loci and will not be identified by this particular test. Therefore, a negative result does not completely exclude the presence of a *BCL2/IGH* gene rearrangement in the sample.<sup>1</sup> In comparison, Southern blot analysis requires 1-2 weeks, is significantly less sensitive, and has more restrictive Specimen requirements.

### Summary and Explanation of the Test

Four master mixes are included in this assay. Three are used to identify translocations in the major breakpoint region (MBR) and minor cluster region (mcr) of *BCL2*. The Specimen Control Size Ladder master mix targets multiple genes and generates a series of amplicons of approximately 100, 200, 300, 400, and 600 base pairs to ensure that the quality and quantity of input DNA is adequate to yield a valid result. This assay includes negative control DNA and positive control DNAs for both the MBR and mcr. PCR products can be analyzed using standard gel electrophoresis with ethidium bromide staining. A *BCL2* translocation is indicated if any one of the master mixes generates product(s) within the valid size range.

### Specimen Requirements

- 5 mL of peripheral blood, bone marrow biopsy, or bone marrow aspirate anti-coagulated with heparin or EDTA; or,
- Minimum 5 mm cube of tissue; or,
- 2 µg of genomic DNA; or,
- Formalin-fixed, paraffin-embedded (FFPE) tissue or slides.

### Reference

1. PAS Evans et al., *Leukemia* 17: 2298-2301 (2003).
2. JJM van Dongen et al., *Leukemia* 17: 2257-2317 (2003).

### Background

The *BCL2* t(14;18)(q32;q21) translocation is found in 80-90% of follicular lymphomas and 30% of diffuse large cell lymphomas. The translocation is rarely present in other lymphoproliferative diseases.



This assay is based on the EuroClonality/BIOMED-2 Concerted Action BMH4-CT98-3936.

**Figure Legend:** Schematic diagram of the *IGH-BCL2* t(14;18) translocation showing the *BCL2* gene on the left and the Ig heavy chain (*IGH*) gene on the right. Shown are the relative positions and orientations for the major breakpoint region (MBR) primers, the minor cluster region (mcr) primers, and the J<sub>H</sub> primer, which are included in the 3 *BCL2/JH* master mix tubes.



t(14;18) tube A: 2 *BCL2* MBR primers + 1 J<sub>H</sub> primer

t(14;18) tube B: 4 *BCL2* 3'MBR primers + 1 J<sub>H</sub> primer

t(14;18) tube C: 3 *BCL2* mcr primers + 1 J<sub>H</sub> primer



# Gel and Capillary

*BCL2/JH* Translocation Assay

Research Use Only (RUO) Assay

## Reagents

Controls	Concentration	Units in Assay	Units in Assay MegaKit
IVS-0030 Clonal Control DNA	200 µg/mL	1 x 100 µL tube	5 x 100 µL tubes
IVS-P002 Clonal Control DNA	1600 pg/mL	1 x 100 µL tube	5 x 100 µL tubes
IVS-0031 Clonal Control DNA	200 µg/mL	1 x 100 µL tube	5 x 100 µL tubes
IVS-0000 Polyclonal Control DNA	200 µg/mL	1 x 100 µL tube	5 x 100 µL tubes
Master Mixes	Target	Units in Assay	Units in Assay MegaKit
<i>BCL2/JH</i> Tube A	<i>BCL2</i> MBR + <i>IGH JH</i>	1 x 1500 µL tube	10 x 1500 µL tubes
<i>BCL2/JH</i> Tube B	<i>BCL2</i> 3' MBR + <i>IGH JH</i>	1 x 1500 µL tube	10 x 1500 µL tubes
<i>BCL2/JH</i> Tube C	<i>BCL2</i> mcr + <i>IGH JH</i>	1 x 1500 µL tube	10 x 1500 µL tubes
Specimen Control Size Ladder	Multiple Genes	1 x 1500 µL tube	10 x 1500 µL tubes

## Gel Electrophoresis Detection

The data shown was generated using the master mix indicated. Amplified products were run on a 2% agarose/TBE gel. Lane 1 is data generated testing an alternative 100% clonal control DNA; lane 2 is data generated testing the recommended 100% clonal control DNA; lane 3 is data generated testing a 1% dilution of the recommended clonal control DNA; and, lane 4 is data generated testing IVS-0000 Polyclonal Control DNA (Cat# 4-092-0010). The IVS-0000 control is used as a negative control for many of our tests. A standard 100 base pair DNA size ladder was run in the lanes flanking the test samples.

### *BCL2/JH* Tube A

Lane 1 = 100% IVS-0007  
 Lane 2 = 100% IVS-0030  
 Lane 3 = 1% IVS-0030  
 Lane 4 = 100% IVS-0000

Valid Size Range =  
 100-2500 bp

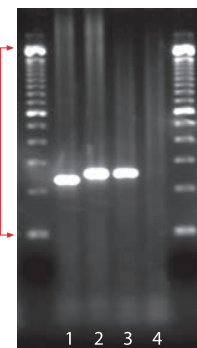

## Ordering Information

Catalog #	Products	Quantity
1-309-0020	<i>BCL2/JH</i> Translocation Assay - Gel Detection	33 reactions
1-309-0040	<i>BCL2/JH</i> Translocation Assay MegaKit - Gel Detection	330 reactions

## BCR/ABL t(9;22) Translocation Assays

### Assay Use

BCR/ABL t(9;22) Translocation Assays are useful for studies involving:

- Identification of chronic myeloid leukemia (CML), acute lymphoblastic leukemia (ALL)
- Monitoring and evaluation of disease recurrence
- Detection and assessment of residual disease
- Evaluation of new research and methods in malignancy studies

### Summary and Explanation of the Test

The master mixes are included in these assay kits used to amplify complementary DNA (cDNA) produced from specimen(s), and positive and negative RNA controls (included). Primers target an internal control transcript (*Ab1*) and p190-, p210-, and p230-type transcripts expressed from *BCR-ABL1* translocations. The limit of detection of this assay is approximately one *BCR-ABL1* positive cell in a background of one million normal cells. Amplicon products can be analyzed by capillary electrophoresis or standard gel electrophoresis with ethidium bromide staining. A *BCR-ABL1* translocation is indicated if just one of the 2nd round master mixes (Mix 2b, Mix 2c, Mix 3b, Mix 3c, or Mix 3d) generates product(s) of the valid size. Reagents for RNA extraction and reverse transcription are not included. This assay is compatible with all standard RNA extraction and cDNA synthesis methods. This is a qualitative assay and has not been validated for quantitative use.

### Background

The Philadelphia chromosome (Ph1) is a specific chromosomal abnormality that results from reciprocal t(9;22)(q34;q11) chromosome rearrangements that fuse coding regions of the *BCR* gene, located on

chromosome 22, with the *ABL* receptor independent tyrosine kinase gene on chromosome 9.<sup>1,2</sup> *BCR-ABL1* t(9;22) translocations are present in approximately 95% of chronic myeloid leukemia (CML) patients, 20-50% of adult acute lymphoblastic leukemia (ALL) patients, and 2-10% of pediatric ALL patients.<sup>2</sup> Although cytogenetic detection of Ph1 is a hallmark of CML, molecular detection of Ph1-positive cells by nested reverse transcriptase PCR is faster and significantly more sensitive than cytogenetics or other methods. Nearly 50% of cytogenetically Ph1-negative CML cases are positive by reverse transcriptase PCR analysis. This makes reverse transcriptase PCR detection of Ph1-positive cells of value in predicting early disease recurrence and progression for CML and ALL patients that are in apparent clinical remission following bone marrow transplantation.<sup>3</sup> Molecular detection provides the opportunity for early intervention and treatment. Thus, molecular testing for chimeric *BCR-ABL1* transcripts is utilized both in diagnostic evaluation and post-therapeutic monitoring of CMLs and ALLs.

### Specimen Requirements

- 5 mL of peripheral blood, bone marrow biopsy, or bone marrow aspirate anticoagulated with heparin or EDTA; or,
- Archived cells frozen in 10% DMSO + 90% Fetal Bovine Serum (FBS).

### Reference

1. R Kurzrock et al., *Ann. Intern. Med.* 138: 819-30 (2003).
2. J.V. Melo. *Blood* 88: 2375-2384 (1996).
3. J.P. Radich et al., *Blood* 85: 2632-2638 (1995).

**Figure Legend:** This figure shows the genomic organization of the *BCR* and *ABL* genes on chromosomes 22 and 9, respectively. Boxes represent exon regions of the *ABL* (red boxes) and *BCR* encoding exons (other colors). The solid black line represents intron regions, which have been left incompletely spliced to assist in demarcation of the exon segments. The location of exon regions targeted by labeled and unlabeled primers are indicated by arrows. A p210-type *BCR-ABL1* translocation (b3a2 junction) is depicted in the lower portion of the figure along with the control *ABL* transcript control.

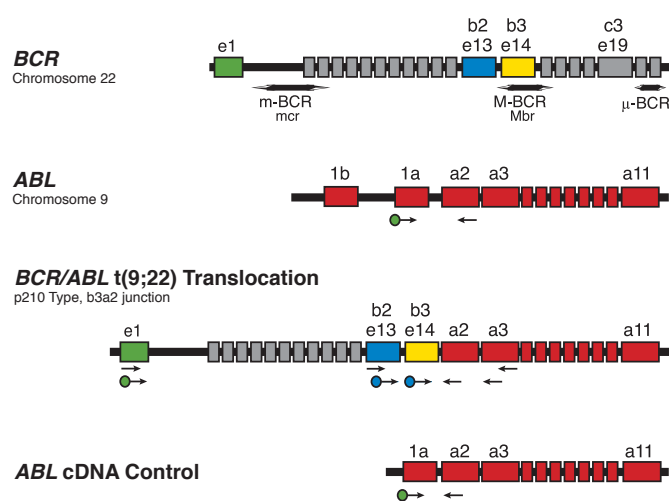

# Gel and Capillary

*BCR/ABL t(9;22) Translocation Assays*

Research Use Only (RUO) Assay

## Reagents

Controls	Concentration	Units in Assay	Units in Assay MegaKit
IVS-0032 Clonal Control RNA	400 µg/mL	1 x 100 µL tube	5 x 100 µL tubes
IVS-0011 Clonal Control RNA	400 µg/mL	1 x 100 µL tube	5 x 100 µL tubes
IVS-0035 Clonal Control RNA	400 µg/mL	1 x 100 µL tube	5 x 100 µL tubes
Master Mixes	Target	Units in Assay	Units in Assay MegaKit
<i>BCR/ABL t(9;22) Mix 1a</i>	<i>Abl</i>	1 x 1500 µL tube	10 x 1500 µL tubes
<i>BCR/ABL t(9;22) Mix 2a</i>	p190	1 x 1500 µL tube	10 x 1500 µL tubes
<i>BCR/ABL t(9;22) Mix 3a</i>	p210+230	1 x 1500 µL tube	10 x 1500 µL tubes
<i>BCR/ABL t(9;22) Mix 1b</i>	<i>Abl</i>	1 x 1500 µL tube	10 x 1500 µL tubes
<i>BCR/ABL t(9;22) Mix 2b</i>	p190	1 x 1500 µL tube	10 x 1500 µL tubes
<i>BCR/ABL t(9;22) Mix 2c</i>	p190	1 x 1500 µL tube	10 x 1500 µL tubes
<i>BCR/ABL t(9;22) Mix 3b</i>	p210+230	1 x 1500 µL tube	10 x 1500 µL tubes
<i>BCR/ABL t(9;22) Mix 3c</i>	p210+230	1 x 1500 µL tube	10 x 1500 µL tubes
<i>BCR/ABL t(9;22) Mix 3d</i>	p210+230	1 x 1500 µL tube	10 x 1500 µL tubes

## Gel Electrophoresis Detection

The data shown was generated using the master mix indicated. Amplified products were run on a 6% polyacrylamide/TBE gel. Lane 1 is data generated testing cDNA synthesized from an alternative 100% clonal control RNA; lane 2 is data generated testing cDNA synthesized from the recommended 100% clonal control RNA; lane 3 is data generated testing cDNA synthesized from a 10<sup>-4</sup> dilution of the recommended clonal control RNA. The positive RNA was diluted into the negative control RNA, IVS-0035. A standard 100 base pair DNA size ladder was run in the lanes flanking the test samples.

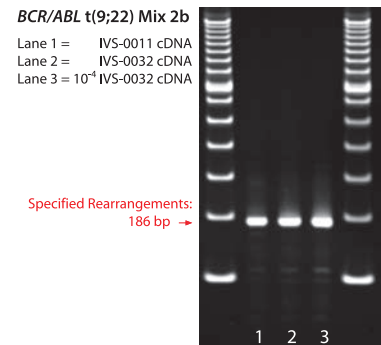

## Capillary Electrophoresis Detection (ABI)

The data shown was generated on an ABI 3100 instrument using the master mix indicated. Panel 1 represents data generated testing cDNA synthesized from an alternative 100% control RNA; panel 2 represents data generated testing cDNA synthesized from the recommended 100% clonal control RNA; and, panel 3 represents data generated testing cDNA synthesized from a 10<sup>-4</sup> dilution of the recommended clonal control RNA. The positive RNA was diluted into the negative control RNA, IVS-0035 (Cat# 4-089-3070).

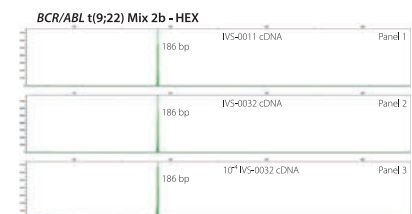

## Ordering Information

Catalog #	Products	Quantity
1-310-0010	<i>BCR/ABL t(9;22) Translocation Assay - Gel Detection</i>	30 reactions
1-310-0020	<i>BCR/ABL t(9;22) Translocation Assay MegaKit - Gel Detection</i>	300 reactions
1-310-0031	<i>BCR/ABL t(9;22) Translocation Assay - ABI Fluorescence Detection</i>	30 reactions
1-310-0041	<i>BCR/ABL t(9;22) Translocation Assay MegaKit - ABI Fluorescence Detection</i>	300 reactions

## *PML/RARα* t(15;17) Translocation Assays

### Assay Use

*PML/RARα* t(15;17) Translocation Assays are useful for studies involving:

- Identification of acute promyelocytic leukemia (APL)
- Monitoring and evaluation of disease recurrence
- Detection and assessment of residual disease
- Evaluation of new research and methods in malignancy studies

### Summary and Explanation of the Test

Four master mixes are included in these assay kits. Master mixes are used to amplify complementary DNA (cDNA) produced from specimen(s), as well as positive and negative RNA controls (included). Primers target an internal control transcript (*RARA*, formerly known as *RARα*) and the variety of Bcr1, Bcr2, and Bcr3 type transcripts expressed from *PML-RARA* translocations. The limit of detection for this assay is one *PML-RARA* positive cell in a background of one hundred thousand normal cells. Amplicon products can be analyzed by differential fluorescence detection using capillary electrophoresis or standard gel electrophoresis. A *PML-RARA* translocation is indicated if just one of the 2nd round master mixes (Mix 2b or Mix 2c) generates product(s) of the valid size. Reagents for RNA extraction and reverse transcription are not included. This assay is compatible with all standard RNA extraction and cDNA synthesis methods. This is a qualitative assay and has not been validated for quantitative use.

### Background

Acute promyelocytic (M3) leukemia (APL) is a distinct form of acute myeloid leukemia (AML) representing approximately 10% of AMLs. These leukemias often express *PML-RARA* transcripts from t(15;17) chromosomal translocations that fuse the *PML* (or *MYL*) gene on chromosome 15 with the retinoic acid receptor  $\alpha$  (*RARA*) gene on chromosome 17.<sup>1,2,3,4</sup> Diagnosis of APL is typically based upon identification of promyelocytes with distinctive morphology plus

cytogenetic or molecular detection of these t(15;17) translocations.<sup>4</sup>

Three *PML/RARA* translocation patterns have been identified:

Type A is the short form (S-form); the breakpoint occurs within the breakpoint cluster region 3 (Bcr3). Type B is the long form (L-form) and the breakpoint occurs within Bcr1. There is a third type B variant or variable form (V-form) whose breakpoint occurs within Bcr2. Identification of the *PML-RARA* translocation is important in APL because it is correlated with responsiveness to treatment with all-trans retinoic acid (ATRA). Patients incorrectly diagnosed with APL by clinical and morphologic criteria alone are typically unresponsive to treatment with ATRA. APL patients are also at risk for disseminated intravascular coagulation (DIC), which can become more severe during conventional chemotherapy. As a result, there is clearly a need for a rapid, sensitive, and reliable molecular assay that identifies *PML-RARA* transcripts associated with APL. This Assay uses both non-nested (master mix 1) and nested (master mixes 2a, 2b, and 2c) reverse transcriptase PCR for faster and significantly more sensitive results than cytogenetics or other methods.

### Specimen Requirements

- 5 mL of peripheral blood, bone marrow biopsy, or bone marrow aspirate anticoagulated with heparin or EDTA; or,
- Archived cells frozen in 10% DMSO + 90% Fetal Bovine Serum (FBS).

### Reference

1. H De Thé et al., *Nature* 347: 558-561 (1990).
2. H De Thé et al., *Cell* 66: 675-684 (1991).
3. A Kakizuka et al., *Cell* 66: 663-674 (1991).
4. WH Miller et al., *Proc. Natl. Acad. Sci.* 89: 2694-2698 (1992).

**Figure Legend:** This figure shows the genomic organization of the *PML* and *RARA* genes on chromosomes 15 and 17, respectively. Boxes represent exon regions of the *PML* (red boxes) and *RARA* (orange) encoding exons. The solid black line represents intron regions, which were left incompletely spliced to assist in demarcation of the exon segments. Primers are indicated by arrows, and the size of several of the products are indicated below the translocated gene segments. S-form (Bcr3) and L-form (Bcr1) *PML-RARA* translocations are depicted in the lower portion of the figure.

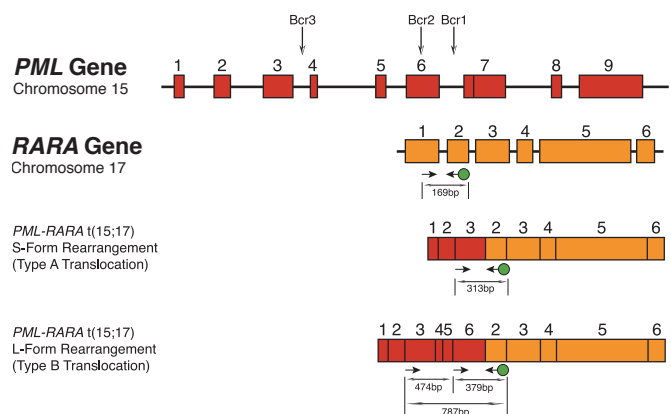

# Gel and Capillary

*PML/RARα* t(9;22) Translocation Assays

Research Use Only (RUO) Assay

## Reagents

Controls	Concentration	Units in Assay	Units in Assay MegaKit
IVS-0020 Clonal Control RNA	400 µg/mL	1 x 100 µL tube	5 x 100 µL tubes
IVS-0035 Clonal Control RNA	400 µg/mL	1 x 100 µL tube	5 x 100 µL tubes
Master Mixes	Target	Units in Assay	Units in Assay MegaKit
<i>PML/RARα</i> t(15;17) Mix 1	<i>RARA</i>	1 x 1500 µL tube	10 x 1500 µL tubes
<i>PML/RARα</i> t(15;17) Mix 2a	<i>PML-RARA</i>	1 x 1500 µL tube	10 x 1500 µL tubes
<i>PML/RARα</i> t(15;17) Mix 2b	S- and L-Forms	1 x 1500 µL tube	10 x 1500 µL tubes
<i>PML/RARα</i> t(15;17) Mix 2c	L-Form	1 x 1500 µL tube	10 x 1500 µL tubes

## Gel Electrophoresis Detection

The data shown were generated using the master mix indicated. Amplified products were run on a 6% polyacrylamide/TBE gel. Lane 1 is data generated testing cDNA synthesized from the recommended 100% clonal control RNA; lane 2 is data generated testing cDNA synthesized from a 10<sup>-4</sup> dilution of the recommended clonal control RNA; and, lane 3 is data generated testing cDNA synthesized from the negative control the negative control IVS-0035 Clonal Control RNA (Cat# 4-089-3070). A standard 100 base pair DNA size ladder was run in the lanes flanking the test samples.

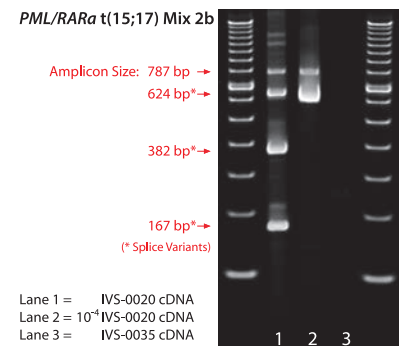

## Capillary Electrophoresis Detection (ABI)

The data shown were generated on an ABI 3100 instrument using the master mix indicated. Panel 1 represents data generated testing cDNA synthesized from the recommended 100% clonal control RNA; panel 2 represents data generated testing cDNA synthesized from a 10<sup>-4</sup> dilution of the recommended clonal control RNA; and, panel 3 represents data generated testing cDNA synthesized from the negative control RNA. The positive RNA was diluted into the negative control RNA, IVS-0035 (Cat# 4-089-3070).

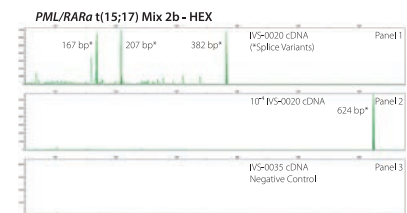

## Ordering Information

Catalog #	Products	Quantity
1-311-0010	<i>PML/RARα</i> t(15;17) Translocation Assay - Gel Detection	30 reactions
1-311-0020	<i>PML/RARα</i> t(15;17) Translocation Assay MegaKit - Gel Detection	300 reactions
1-311-0011	<i>PML/RARα</i> t(15;17) Translocation Assay - ABI Fluorescence Detection	30 reactions
1-311-0021	<i>PML/RARα</i> t(15;17) Translocation Assay MegaKit - ABI Fluorescence Detection	300 reactions

## IGH Somatic Hypermutation Assays v2.0

### Assay Use

IGH Somatic Hypermutation Assays are useful for studies involving:

- Identifying clonal rearrangements of the immunoglobulin heavy chain (*IGH*) gene
- Assessing the extent of somatic hypermutation (SHM) in the variable (*VH*) gene sequence (*IGHV*) in patients with chronic lymphocytic leukemia (CLL) and small lymphocytic lymphoma (SLL)
- Evaluating new research and methods in malignancy studies

### Summary and Explanation of the Test

These assays amplify either genomic DNA or complementary DNA (cDNA) that lies between the upstream leader (*VH*L) or framework 1 (*FR*1) regions and the downstream joining (*JH*) region of the *IGH* gene. The assays employ two different master mixes: Hypermutation Mix 1 and Hypermutation Mix 2. The Hypermutation Mix 1 targets sequences between the leader (*VH*L) and joining (*JH*) regions. Therefore the amplicon product(s) span the entire variable (*VH*) region, which contains all framework (*FR*) and complementarity-determining regions (*CDR*). The Hypermutation Mix 2 targets sequences between the framework 1 (*FR*1) and joining (*JH*) regions. The resulting amplicons include a portion of the *FR*1 region to the downstream *JH* region. The primers that target the *VH*L and *FR*1 regions have been redesigned to include a universal sequencing tag at the 5' end. This new design allows for bi-directional sequencing of clonal PCR products with just one sequencing-tag specific forward primer and one *JH* reverse primer, thus ensuring a more reliable and complete coverage of clonal products. Current ERIC (European Research Initiative on CLL) guidelines recommend bi-directional sequencing when determining the *IGH* SHM status. Positive and negative DNA, positive RNA, as well as an amplification control are included in the assay. Clonality is indicated if any one of the master mixes generates clonal products.

### Background

Immunoglobulin variable heavy chain gene hypermutation status provides important prognostic information for patients with chronic lymphocytic leukemia (CLL) and small lymphocytic lymphoma (SLL). The presence of *IGH* somatic hypermutation (SHM) is defined as greater or equal to 2% difference from the germline variable (*VH*) gene sequence, whereas less than 2% difference is considered evidence of no somatic hypermutation. This has clinical relevance, as there is a clear distinction in the median survival of patients with and without somatic hypermutation.<sup>2</sup> Hypermutation of the *IGHV* gene is strongly predictive of a good prognosis while lack of mutation predicts a poor prognosis. This assay aids in identification, sequencing, and analysis of somatic hypermutation status of clonal products. PCR products can be analyzed by gel electrophoresis detection or by differential fluorescence detection using capillary electrophoresis followed by gel electrophoresis detection. PCR products are sequenced bidirectionally either directly, after gel extraction, or after cloning into a bacterial vector. The resulting sequence is then compared to *IGH* germline sequences to determine mutational status.

### Specimen Requirements

These assays test genomic DNA or cDNA from the following sources:

- 5 mL of peripheral blood, bone marrow biopsy, or bone marrow aspirate anti-coagulated with heparin or EDTA; or,
- Minimum 5 mm cube of tissue; or,
- 2 µg of genomic DNA; or,
- 5 µg of total RNA or mRNA; or,
- 1 µg of cDNA; or,
- Formalin-fixed, paraffin-embedded (FFPE) tissue or slides.

### Reference

1. P Ghia et al., *Leukemia* 21: 1-3 (2007).
2. P Ghia et al., *Blood* 105: 1678-1685 (2005).
3. F Davi et al., *Leukemia* 22: 212-214 (2008).

**Figure Legend:** Simple representation of the organization of a rearranged immunoglobulin heavy chain gene on chromosome 14. Black arrows represent the relative positions of primers that target the conserved Leader (L) and Framework 1 (FR1) regions, and the downstream consensus *JH* gene segments.

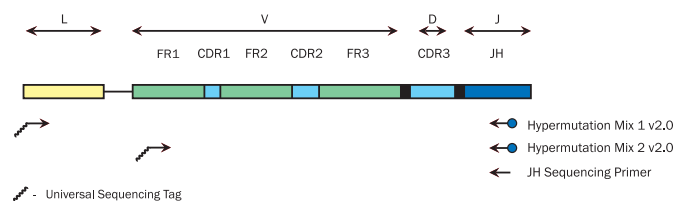

# Gel and Capillary

*IGH* Somatic Hypermutation Assays v2.0

Research Use Only (RUO) Assay

## Reagents

Controls	Concentration	Units in Assay	Units in Assay MegaKit
IVS-0013 Clonal Control DNA	200 µg/mL	1 x 100 µL tube	5 x 100 µL tubes
IVS-0013 Clonal Control RNA	400 µg/mL	1 x 100 µL tube	5 x 100 µL tubes
IVS-0000 Polyclonal Control DNA	200 µg/mL	1 x 100 µL tube	5 x 100 µL tubes
Master Mixes	Target	Units in Assay	Units in Assay MegaKit
Hypermutation Mix 1 v2.0	Leader + JH	1 x 1500 µL tube	10 x 1500 µL tubes
Hypermutation Mix 2 v2.0	Framework 1 + JH	1 x 1500 µL tube	10 x 1500 µL tubes
Specimen Control Size Ladder	Multiple Genes	1 x 1500 µL tube	10 x 1500 µL tubes
Primers	Target	Units in Assay	Units in Assay MegaKit
Primer - Hypermutation	Leader + Framework 1	1 x 10 µL tube at 100 µM	5 x 10 µL tube
<i>IGH</i> JH Primer	JH	1 x 10 µL tube at 100 µM	5 x 10 µL tube

## Gel Electrophoresis Detection

The data shown was generated using the master mix indicated. Amplified products were run on a 2% agarose/TBE gel. Lane 1 is data generated testing cDNA synthesized from the recommended 100% clonal control RNA; lane 2 is data generated testing the recommended 100% clonal control DNA; lane 3 is data generated testing a 10% dilution of the recommended clonal control DNA; and, lane 4 is data generated testing the IVS-0000 Polyclonal Control DNA (Cat# 4-092-0010). Lanes flanking the samples were loaded with a 100 base pair DNA size standard.

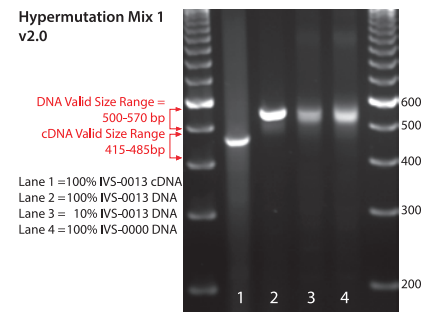

## Capillary Electrophoresis Detection (ABI)

The data shown was generated on an ABI 3130xl instrument using the master mix indicated. Panel 1 displays data generated testing cDNA synthesized from the recommended 100% clonal control RNA; panel 2 displays data generated testing the recommended 100% clonal control DNA; panel 3 displays data generated testing the recommended 10% clonal control DNA; and panel 4 displays data generated testing IVS-0000 Polyclonal Control DNA (Cat# 4-092-0010).

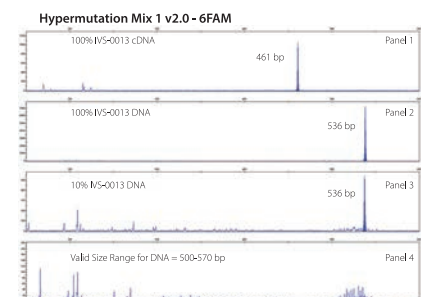

## Ordering Information

Catalog #	Products	Quantity
5-101-0030	<i>IGH</i> Somatic Hypermutation Assay v2.0 - Gel Detection	33 reactions
5-101-0040	<i>IGH</i> Somatic Hypermutation Assay v2.0 MegaKit - Gel Detection	330 reactions
5-101-0031	<i>IGH</i> Somatic Hypermutation Assay v2.0 - ABI Fluorescence Detection	33 reactions
5-101-0041	<i>IGH</i> Somatic Hypermutation Assay v2.0 MegaKit - ABI Fluorescence Detection	330 reactions

## FLT3 Mutation Assays

These products are not currently available for sale or use in the United States.

### Assay Use

FLT3 Mutation Assays are useful for the study of:

- Identifying *FLT3* mutations in patients with AML
- Discriminating between high and low risk patients. *FLT3* mutations portend a worse prognosis for patients with AML. Therefore patients testing positive for *FLT3* mutations may benefit from a more aggressive treatment regimen

### Summary and Explanation of the Test

Acute myeloid leukemia (AML) in general has a poor prognosis. Recent studies have described mutation of the *FLT3* (fms-related tyrosine kinase 3) receptor to be the most important prognostic factor in AML, with *FLT3* mutants having a worse outcome and response to standard chemotherapeutic interventions. Accordingly, identification of an *FLT3* mutation in AML may indicate a need to reassess and modify standard treatment options.

All types of AML can have activating mutations in the *FLT3* gene. Mutation of the *FLT3* receptor, either by internal tandem duplication (ITD) of the juxtamembrane domain or by point mutation of the aspartic acid residue (D835) or isoleucine (I836) in the activation loop of the kinase domain, causes constitutive activation of the *FLT3* receptor.

This test kit includes three master mixes. The ITD and D835 master mixes target the juxtamembrane and kinase domain regions (respectively). The third master mix, the Specimen Control Size Ladder, targets multiple genes and generates a series of amplicons of 100, 200, 300, 400, and 600 base pairs to ensure that the quality and quantity of input DNA is adequate to yield a valid result.

PCR products can be analyzed by capillary electrophoresis with use of ABI instruments or standard agarose TBE gel electrophoresis with ethidium bromide staining.

### Background

Mutations in the fms related tyrosine kinase 3 (*FLT3*) gene are the most common mutations found in acute myeloid leukemia (AML), occurring in approximately 30% of patients at the time of diagnosis, and are characterized by an aggressive phenotype with a high prevalence of relapse.<sup>1,2,3</sup>

The most prevalent and clinically significant type of *FLT3* mutation is an internal tandem duplication (ITD) in the juxtamembrane domain.<sup>4</sup> Many clinical studies have found that *FLT3* ITD mutations are associated with higher concentrations of leukemic cells in both blood and bone marrow, increased incidence of relapse, and decreased overall survival.

The second most common mutation type in the *FLT3* gene is a tyrosine kinase domain (TKD) point mutation in aspartate (D835) or isoleucine (I836). TKD mutations result in constitutive autophosphorylation and activation of *FLT3*.<sup>5,6</sup> TKD mutations have been linked to poor overall survival, but to a lesser extent as compared to ITD mutations.

### Specimen Requirements

- 5 cc of peripheral blood, bone marrow biopsy, or bone marrow aspirate anti-coagulated with heparin or EDTA; or,
- Minimum 5 mm cube of tissue; or,
- 2 µg of genomic DNA; or,
- Formalin-fixed, paraffin-embedded tissue or slides.

### Reference

1. Acute Myeloid Leukemia, Clinical Practice Guidelines in Oncology, National Comprehensive Cancer Network (v.2.2014).
2. Lowenberg, B. et al. "Acute myeloid leukemia." *N Engl J Med* 341(14):1051-62 (1999).
3. Thiede, C. et al. "Analysis of *FLT3*-activating mutations in 979 patients with acute myelogenous leukemia: association with FAB and identification of subgroups with poor prognosis." *Blood* 99(12): 4326-35 (2002).
4. Nakao, M. et al. "Internal tandem duplication of the *FLT3* gene found in acute myeloid leukemia." *Leukemia* 10(12):1911-18 (1996).
5. Yamamoto, Y et al. Activating mutation of D835 within the activation loop of *FLT3* in human hematologic malignancies. *Blood*, 97(8):2434-9 (2001).
6. Gilliland, DG et al. The roles of *FLT3* in hematopoiesis and leukemia. *Blood* 100(5):1532-154 (2002).



## Reagents

Controls	Concentration	Units in 33 Reaction Assay	Units in 330 Reaction MegaKit
IVS-0017 Clonal Control DNA	200 µg/mL	1 x 100 µL tube	5 x 100 µL tubes
IVS-P001 Clonal Control DNA	200 µg/mL	1 x 100 µL tube	5 x 100 µL tubes
IVS-0000 Polyclonal Control DNA	200 µg/mL	1 x 100 µL tube	5 x 100 µL tubes
Master Mixes	Target	Units in 33 Reaction Assay	Units in 330 Reaction MegaKit
<i>FLT3</i> ITD Master Mix	<i>FLT3</i> ITD	1 x 1500 µL tube	10 x 1500 µL tubes
<i>FLT3</i> D835 Master Mix	<i>FLT3</i> TKD	1 x 1500 µL tube	10 x 1500 µL tubes
Specimen Control Size Ladder	Multiple Genes	1 x 1500 µL tube	10 x 1500 µL tubes

## Gel Electrophoresis Detection

Data was generated using the *FLT3* ITD Master Mix and amplified products were run on a 2% agarose TBE gel. Lane 1 is a *FLT3* ITD control\*; lane 2 is a 10% dilution of a *FLT3* ITD control; and lane 3 is IVS-0000, which is representative of a WT product. A standard 100 bp DNA size ladder was run in the lanes flanking the test samples.

\*IVS-0050 performs comparable to IVS-0017 clonal control DNA, which is included in the kit as the positive control.

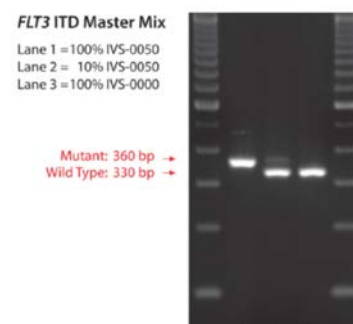

## Capillary Electrophoresis Detection (ABI)

Data was generated using the *FLT3* ITD Master Mix and amplified products were run on an ABI 3100 instrument. Panel 1 is the recommended *FLT3* ITD positive control; panel 2 is data generated testing a 10% dilution of the positive control; and Panel 3 is IVS-0000, which is representative of a WT product.

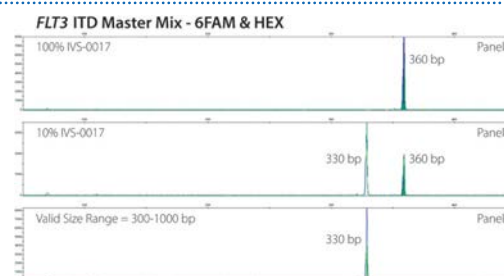

## Ordering Information

Catalog #	Products	Quantity
1-412-0010	<i>FLT3</i> Mutation Assay - Gel Detection	33 reactions
1-412-0020	<i>FLT3</i> Mutation Assay MegaKit - Gel Detection	330 reactions
1-412-0031	<i>FLT3</i> Mutation Assay - ABI Fluorescence Detection	33 reactions
1-412-0041	<i>FLT3</i> Mutation Assay MegaKit - ABI Fluorescence Detection	330 reactions

# Analyte Specific Reagents

## WARRANTY AND LIABILITY

Invivoscribe, Inc. (Invivoscribe®) is committed to providing the highest quality products. Invivoscribe® warrants that the products meet or exceed the performance standards described in the Instructions For Use, as to products with such an insert. If a product is covered by product specifications and does not perform as specified, our policy is to replace the product or credit the full purchase price. No other warranties of any kind, expressed or implied, are provided by Invivoscribe®. Invivoscribe® liability shall not exceed the purchase price of the product. Invivoscribe® shall have no liability for direct, indirect, consequential, or incidental damages arising from the use, results of use, or inability to use its products; product efficacy under purchaser controlled conditions in purchaser's laboratory must be established and continually monitored through purchaser defined and controlled processes including but not limited to testing of positive, negative, and blank controls every time a sample is tested. Ordering, acceptance, and use of product constitutes purchaser acceptance of sole responsibility for assuring product efficacy and purchaser agreement to the limitation of liability set forth in this paragraph.

NOTICE: The products in this section are Analyte Specific Reagents; the analytical and performance characteristics are not established. Use of many of these products are covered by one or more of the following: European Patent Number 1549764, European Patent Number 2418287, European Patent Number 2460889, Japanese Patent Number 4708029, United States Patents 6846630, 8178292, 8859748, 10280462, and related pending and future applications. All of these patents and applications are licensed exclusively to Invivoscribe®. Additional patents licensed to Invivoscribe covering some of these products apply elsewhere.

These products require nucleic acid amplification methods such as Polymerase Chain Reaction (PCR). No license under these patents to use amplification processes or enzymes is conveyed expressly or by implication to the purchaser by the purchase of these products.

# Analyte Specific Reagents

Inivoscribe Analyte Specific Reagents (ASRs) target B- and T-cell antigen receptor loci, *FLT3* ITD and TKD, or chromosome translocations (*IGH* - *BCL2*, *BCR*-*ABL1*, *PML*-*RARA*).

The ASRs are available as a single tube containing a volume of 1500 µL. To ensure the highest quality and reliability of reagents ASRs are manufactured under cGMP and ISO 13485 standards. **The analytical and performance characteristics of the ASRs have not been established.**

Per the current US FDA regulations, ASRs may only be sold to *in vitro* diagnostic manufacturers, CLIA accredited high complexity laboratories, VHA regulated clinical laboratories, and laboratories not intending to use ASRs as a part of a diagnostic test.

ASRs are not available for sale or use outside of the USA.

<i>FLT3</i> (FMS-like Tyrosine Kinase 3)	
Description	Catalog #
<i>FLT3</i> ITD Master Mix - Unlabeled	Please contact Inivoscribe
<i>FLT3</i> TKD Master Mix - Unlabeled	Please contact Inivoscribe
<i>FLT3</i> ITD Master Mix - 6FAM & HEX - ASR	A-412-0071
<i>FLT3</i> TKD Master Mix - 6FAM - ASR	A-412-0081

<i>IGH</i> (Immunoglobulin Heavy Chain Gene Locus)	
Description	Catalog #
<i>IGH</i> Framework 1 - 6FAM	A-101-0061
<i>IGH</i> Framework 2 - Unlabeled	A-101-0070
<i>IGH</i> Framework 2 - 6FAM	A-101-0091
<i>IGH</i> Framework 3 - Unlabeled	A-101-0080
<i>IGH</i> Framework 3 - HEX	A-101-0081
<i>IGH</i> FR1 - Unlabeled	A-101-0010
<i>IGH</i> FR1 - 6FAM	A-101-0011
<i>IGH</i> FR2 - Unlabeled	A-101-0020
<i>IGH</i> FR2 - 6FAM	A-101-0101
<i>IGH</i> FR3 - Unlabeled	A-101-0030
<i>IGH</i> FR3 - HEX	A-101-0031
<i>IGH</i> Dh1 - 6 - HEX	A-101-0041
<i>IGH</i> Dh7 - 6FAM	A-101-0051

<i>IGK</i> (Immunoglobulin Kappa Light Chain Gene Locus)	
Description	Catalog #
<i>IGKV</i> - J - Unlabeled	A-102-0010
<i>IGKV</i> - J - 6FAM	A-102-0011
<i>IGKV</i> - K <sub>de</sub> - Unlabeled	A-102-0020
<i>IGKV</i> - K <sub>de</sub> - 6FAM	A-102-0021

<i>IGL</i> (Immunoglobulin Lambda Light Chain Gene Locus)	
Description	Catalog #
<i>IGLV</i> - J - 6FAM	A-103-0011

<i>TRB</i> (T-Cell Receptor Beta Chain Gene Locus)	
Description	Catalog #
<i>TCRBV</i> - J1 + 2 - Unlabeled	A-205-0010
<i>TCRBV</i> - J1 + 2 - 6FAM & HEX	A-205-0011
<i>TCRBV</i> - J2 - Unlabeled	A-205-0020
<i>TCRBV</i> - J2 - 6FAM	A-205-0021
<i>TCRBD</i> - J1 + 2 - Unlabeled	A-205-0030
<i>TCRBD</i> - J1 + 2 - 6FAM & HEX	A-205-0031

<i>TRD</i> (T-Cell Receptor Delta Chain Gene Locus)	
Description	Catalog #
<i>TCRDV</i> - D - J - 6FAM & HEX	A-206-0011

<i>TRG</i> (T-Cell Receptor Gamma Chain Gene Locus)	
Description	Catalog #
<i>TCRG V</i> (2-5,8-11) J 1 + 2 + P - 6FAM	A-207-0091
<i>TCRG V</i> (1-8,9) J - 6FAM	A-207-0071
<i>TCRG V</i> (1-8) J - HEX	A-207-0021
<i>TCRG V</i> (1-8,10) J - Unlabeled	A-207-0030
<i>TCRG V</i> (1-8,10) J - 6FAM & HEX	A-207-0031
<i>TCRG V</i> (9,11) J - Unlabeled	A-207-0040
<i>TCRG V</i> (9,11) J - 6FAM & HEX	A-207-0041

<i>IGH-BCL2</i> t(14;18)	
Description	Catalog #
<i>BCL2</i> J <sub>H</sub> Mbr - Unlabeled	A-309-0050
<i>BCL2</i> J <sub>H</sub> 3'Mbr - Unlabeled	A-309-0060
<i>BCL2</i> J <sub>H</sub> mcr - Unlabeled	A-309-0070

<i>BCR-ABL1</i> t(9;22)	
Description	Catalog #
<i>BCR/ABL</i> e1.1-a3.1 - Unlabeled	A-310-0020
<i>BCR/ABL</i> b2.1-a3.1 - Unlabeled	A-310-0030
<i>BCR/ABL</i> e1.2-a2.2 - HEX	A-310-0051
<i>BCR/ABL</i> e1.2-a3.2 - HEX	A-310-0061
<i>BCR/ABL</i> b2.2-a2.2 - 6FAM	A-310-0071
<i>BCR/ABL</i> b2.2-a3.2 - 6FAM	A-310-0081
<i>BCR/ABL</i> b3.2-a3.2 - 6FAM	A-310-0101

<i>PML-RARA</i> t(15;17)	
Description	Catalog #
<i>PML/RARα</i> , <i>MYL2-RARα</i> - Unlabeled	A-311-0020
<i>PML/RARα</i> , <i>MYL1-RARα</i> - Unlabeled	A-311-0030
<i>PML/RARα</i> , <i>PML3-RARα</i> - Unlabeled	A-311-0040

# Controls, Reagents, and Enzymes

## DNA Controls

134 / Quick Reference for  
DNA Controls

134 / Tissue DNA  
Controls

135 / Cell Line DNA  
Controls

137 / Plasmid DNA  
Controls

## RNA Controls

140 / Quick Refere  
RNA Controls

141 / Cell Line RNA  
Controls

142 / *BCR/ABL1* RNA  
Dilution Sets

## Control Panels

144 / DNA and RNA Sensitivity  
Panels

145 / *BCR/ABL1* Proficiency  
Panel

## Master Mix Controls

146 / Amplification Control  
Master Mix

146 / Specimen Control  
Size Ladder

## Reagents

147 / ABI Detection  
Reagents

## Enzymes

147 / EagleTaq DNA  
Polymerase

### WARRANTY AND LIABILITY

Invivoscribe, Inc. (Invivoscribe®) is committed to providing the highest quality products. Invivoscribe® warrants that the products meet or exceed the performance standards described in the Instructions For Use, as to products with such an insert. If a product is covered by product specifications and does not perform as specified, our policy is to replace the product or credit the full purchase price. No other warranties of any kind, expressed or implied, are provided by Invivoscribe®. Invivoscribe® liability shall not exceed the purchase price of the product. Invivoscribe shall have no liability for direct, indirect, consequential or incidental damages arising from the use, results of use, or inability to use its products; product efficacy under purchaser controlled conditions in purchaser's laboratory must be established and continually monitored through purchaser defined and controlled processes including but not limited to testing of internally validated positive, negative, and blank controls every time a sample is tested. Ordering, acceptance and use of product constitutes purchaser acceptance of sole responsibility for assuring product efficacy and purchaser agreement to the limitation of liability set forth in this paragraph.

### Notice to Purchaser - Taq DNA Polymerase ONLY

This product is for sale and use in the European Economic Area only. It is not to be resold or transferred to another party. Use of this product is covered by US Patent No. 6,127,155 and corresponding patent claims outside the US. This purchaser of this product may use this amount of product only for the purchaser's own internal research. No right under any other patent claim and no right to perform commercial services of any kind, including without limitation reporting the results of purchaser's activities for a fee or other commercial consideration, is conveyed expressly, by implication, or by estoppel. This product is for research use only. Human and veterinary diagnostic uses under Roche patent claims require a separate license from Roche. All uses other than internal research and human and veterinary diagnostic uses under Roche patent claims require a separate license from Thermo Fisher Scientific. By using this product, you acknowledge your agreement to the above. Further information on purchasing licenses from Roche may be obtained by contacting the Licensing Department of Roche Molecular Systems, Inc., 4300 Hacienda Drive, Pleasanton, California 94588, USA or Roche Diagnostics GmbH, Sandhofer Strasse 116, 68305 Mannheim, Germany. Further information on purchasing licenses from Thermo Fisher Scientific may be obtained by contacting the Licensing Department of Thermo Fisher Scientific, 5791 Van Allen Way, Carlsbad, California 92008, USA.

# Controls, Reagents, and Enzymes

Invivoscribe offers an extensive range of General Purpose Reagents (GPRs) and Research Use Only (RUO) nucleic acid controls.

Controls are available in several different formats: plasmid DNA, DNA extracted from tissue or cell lines, or RNA extracted from cell lines. These controls can be purchased in various dilutions or as complete dilution sets and panels for several purposes, such as to help with assay validation, sensitivity or proficiency testing, or troubleshooting.

The following pages will provide an overview of available controls, along with a number of tables and reference guides, to help you decide which Invivoscribe control(s) will be suitable for your application.

# Controls, Reagents, and Enzymes

DNA Controls

## DNA Controls

Every laboratory needs suitable controls (positive and negative) for sensitivity and proficiency testing, as well as for troubleshooting. Since patient samples cannot serve as true controls (due to a lack of characterization and inter-sample variability),

Inivoscribe offers a multitude of high quality, reliable DNA controls manufactured under cGMP conditions.

These controls can be used for most assays targeting B- and T-cell antigen receptor loci, *FLT3* ITD and TKD loci, or *IGH-BCL2*, *BCR-ABL1*, and *PML-RAR $\alpha$*  chromosome translocations.

### Quick Reference for DNA Controls

The vast majority of our high-quality DNA controls, including sensitivity controls and panels, are supplied in aliquots of 100  $\mu$ L and are adjusted to a final concentration of 200  $\mu$ g/mL in 1/10 TE (1 mM Tris- HCl (pH 8.0), 0.1 mM EDTA).

Positive for	Immunoglobulin Rearrangements			Mutations			Translocations		T-Cell Receptor Gene Rearrangements		
	<i>IGH</i>	<i>IGK</i>	<i>IGL</i>	<i>IGHV</i> SHM	<i>FLT3</i> ITD	<i>FLT3</i> TKD	<i>IGH-CCND1</i> **	<i>IGH-BCL2</i>	<i>TRB</i>	<i>TRG</i>	<i>TRD</i>
IVS-0001								◆			
IVS-0004									◆	◆	
IVS-0007	◆	◆	◆					◆			
IVS-0008 <sup>c</sup>	○								◆	◆	
IVS-0009									◆	◆	
IVS-0010	◆	◆					◆				
IVS-0013	◆	◆									
IVS-0019	◆	◆									
IVS-0021		◆							◆	◆	◆
IVS-0024	◆	◆									
IVS-0029	◆	◆									
IVS-0030 <sup>†</sup>	◆	◆		◆							
IVS-0031	◆	◆									
IVS-P002											
LymphoQuant B-cell Internal Control	★	★									
LymphoQuant T-cell Internal Control									★	★	
LymphoTrack B-cell Low Positive Control	★	★									
LymphoTrack T-cell Low Positive Control									★	★	
<i>FLT3</i> ITD Positive Control					◆						
<i>FLT3</i> TKD Positive Control						◆					

◆ Gene rearrangement ○ Partial *IGH* DH-JH rearrangement ★ Recommended for NGS

<sup>c</sup>This control does not contain a complete *IGHVH*-JH rearrangement and may only be suitable for *IGH* DH-JH rearrangements.

\*\**IGH-CCND1* was previously referred to as *BCL11JH*

<sup>†</sup>These controls can be used as SHM positive controls with  $\geq 2\%$  mutational rates compared to the germline sequence.

## Tissue DNA

### Standard Concentrations

The vast majority of our high-quality DNA controls, including sensitivity controls and panels, are supplied in aliquots of 100  $\mu$ L and are adjusted to a final concentration of 200  $\mu$ g/mL in 1/10 TE (1 mM Tris- HCl (pH 8.0), 0.1 mM EDTA). This diluent provides sufficient buffering capacity and EDTA to protect the DNA without interfering with the Mg<sup>2+</sup> concentrations required for robust amplification reactions.

### IVS-0000 Polyclonal Control DNA

Tissue DNA controls are extracted from normal, disease-free tissue and are tested extensively to ensure quality and reproducibility of your test results. IVS-0000 Polyclonal Control DNA consists of genomic DNA isolated from the tissue of normal human tonsils. This control represents an excellent negative control for gene rearrangements, chromosome translocations, and mutation tests and is included in all of our PCR DNA-based assay kits. This DNA is supplied at a volume of 100  $\mu$ L and at a concentration of 200  $\mu$ g/mL.

Catalog #	Description
4-092-0010	IVS-0000 Polyclonal Control DNA*

# Controls, Reagents, and Enzymes

DNA Controls

## Cell Line DNA

### Reliable Positive Controls

Cell Line DNA controls are extracted from established cell lines grown under cell culture conditions recommended by the supplier. Our controls are tested extensively to ensure quality and reproducibility of your test results. Please note, these controls are for qualitative use only.

**Note:** n/c is used to indicate that the control has not been fully characterized; there may be additional rearrangements, translocations or mutations associated with the control.

### Standard Concentrations

The majority of our high-quality DNA controls, including our sensitivity panels, are supplied in aliquots of 100  $\mu$ L and are adjusted to a final concentration of 200  $\mu$ g/mL in 1/10 TE (1 mM Tris-HCl (pH 8.0), 0.1 mM EDTA). This diluent provides sufficient buffering capacity and EDTA to protect the DNA controls without interfering with the Mg<sup>2+</sup> concentrations required for robust amplification reactions. DNA dilutions are diluted volume to volume (v/v) in our negative control DNA, IVS-0000 Polyclonal Control DNA.

### FLT3 ITD Positive Control DNA

The FLT3 ITD Positive Control DNA can be used as a positive control for:

Gene Rearrangements: n/c  
Chromosome Translocations: n/c  
Mutations: FLT3 ITD

Catalog #	Description
R0880230	FLT3 ITD Positive Control (DNA)*

### FLT3 TKD Positive Control DNA

The FLT3 TKD Positive Control DNA can be used as a positive control for:

Gene Rearrangements: n/c  
Chromosome Translocations: n/c  
Mutations: FLT3 TKD

Catalog #	Description
R0880240	FLT3 TKD Positive Control (DNA)*

### FLT3 Extraction Control

This DNA Control is adjusted to a final concentration of 50  $\mu$ g/mL in 1/10 TE (1mM Tris-HCL (pH 8.0), 0.1 mM EDTA). This product is a FLT3 negative cell line DNA that can be used as a DNA extraction control and as a negative control.

Catalog #	Description
R0880250	FLT3 Extraction Control*

### IVS-0001 Clonal Control DNA

IVS-0001 Clonal Control DNA can be used as a positive control for:

Gene Rearrangements: n/c  
Chromosome Translocations: IGH-BCL2 t(14;18) mcr  
Mutations: n/c

Catalog #	Description
4-088-0010	100% IVS-0001 Clonal Control DNA*

### IVS-0004 Clonal Control DNA

IVS-0004 Clonal Control DNA can be used as a positive control for:

Gene Rearrangements: TRB, TRG  
Chromosome Translocations: n/c  
Mutations: n/c

This control is also available as several ready-to-use dilutions into a standard negative control as listed in the table below.

Catalog #	Description
4-088-0190	100% IVS-0004 Clonal Control DNA*
4-088-0210	20% IVS-0004 Clonal Control DNA
4-088-0220	10% IVS-0004 Clonal Control DNA
4-088-0230	5% IVS-0004 Clonal Control DNA

### IVS-0007 Clonal Control DNA

IVS-0007 Clonal Control DNA can be used as a positive control for:

Gene Rearrangements: IGH, IGK, IGL  
Chromosome Translocations: IGH-BCL2 t(14;18) Mbr  
Mutations: n/c

This control is also available as several ready-to-use dilutions into a standard negative control as listed in the table below.

Catalog #	Description
4-088-0370	100% IVS-0007 Clonal Control DNA*
4-088-0390	20% IVS-0007 Clonal Control DNA
4-088-0400	10% IVS-0007 Clonal Control DNA
4-088-0410	5% IVS-0007 Clonal Control DNA
4-088-0420	1% IVS-0007 Clonal Control DNA

\* These controls are general purpose reagents (GPRs). All others are research use only (RUO).

# Controls, Reagents, and Enzymes

DNA Controls

## Cell Line DNA

### IVS-0008 Clonal Control DNA

IVS-0008 Clonal Control DNA can be used as a positive control for:

Gene Rearrangements:	<i>IGH</i> DH-JH <sup>†</sup> , <i>TRB</i> , <i>TRG</i>
Chromosome Translocations:	n/c
Mutations:	n/c

This control is also available as several ready-to-use dilutions into a standard negative control as listed in the table below.

Catalog #	Description
4-088-0430	100% IVS-0008 Clonal Control DNA*
4-088-0460	10% IVS-0008 Clonal Control DNA
4-088-0470	5% IVS-0008 Clonal Control DNA
4-088-0480	1% IVS-0008 Clonal Control DNA

### IVS-0009 Clonal Control DNA

IVS-0009 Clonal Control DNA can be used as a positive control for:

Gene Rearrangements:	<i>TRB</i> , <i>TRG</i>
Chromosome Translocations:	n/c
Mutations:	n/c

This control is also available as several ready-to-use dilutions into a standard negative control as listed in the table below.

Catalog #	Description
4-088-0490	100% IVS-0009 Clonal Control DNA*
4-088-0500	30% IVS-0009 Clonal Control DNA
4-088-0510	20% IVS-0009 Clonal Control DNA
4-088-0520	10% IVS-0009 Clonal Control DNA
4-088-0530	5% IVS-0009 Clonal Control DNA
4-088-0540	1% IVS-0009 Clonal Control DNA

### IVS-0010 Clonal Control DNA

IVS-0010 Clonal Control DNA can be used as a positive control for:

Gene Rearrangements:	<i>IGH</i> , <i>IGK</i> , <i>IGL</i>
Chromosome Translocations:	<i>IGH-BCL1</i> t(11;14)
Mutations:	n/c

This control is also available as several ready-to-use dilutions into a standard negative control as listed in the table below.

Catalog #	Description
4-088-0550	100% IVS-0010 Clonal Control DNA*
4-088-0560	30% IVS-0010 Clonal Control DNA
4-088-0580	10% IVS-0010 Clonal Control DNA
4-088-0590	5% IVS-0010 Clonal Control DNA

### IVS-0013 Clonal Control DNA

IVS-0013 Clonal Control DNA can be used as a positive control for:

Gene Rearrangements:	<i>IGH</i> , <i>IGK</i> , <i>IGL</i>
Chromosome Translocations:	n/c
Mutations:	n/c

Catalog #	Description
4-088-0730	100% IVS-0013 Clonal Control DNA*

### IVS-0019 Clonal Control DNA

IVS-0019 Clonal Control DNA can be used as a positive control for:

Gene Rearrangements:	<i>IGH</i> , <i>IGK</i>
Chromosome Translocations:	n/c
Mutations:	n/c

This control is also available as several ready-to-use dilutions into a standard negative control as listed in the table below.

Catalog #	Description
4-088-1090	100% IVS-0019 Clonal Control DNA*
4-088-1100	30% IVS-0019 Clonal Control DNA
4-088-1110	20% IVS-0019 Clonal Control DNA
4-088-1120	10% IVS-0019 Clonal Control DNA
4-088-1130	5% IVS-0019 Clonal Control DNA
4-088-1140	1% IVS-0019 Clonal Control DNA

### IVS-0021 Clonal Control DNA

IVS-0021 Clonal Control DNA can be used as a positive control for:

Gene Rearrangements:	<i>TRB</i> , <i>TRD</i> , <i>TRG</i>
Chromosome Translocations:	n/c
Mutations:	n/c

This control is also available as several ready-to-use dilutions into a standard negative control as listed in the table below.

Catalog #	Description
4-088-1210	100% IVS-0021 Clonal Control DNA*
4-088-1220	30% IVS-0021 Clonal Control DNA
4-088-1230	20% IVS-0021 Clonal Control DNA
4-088-1240	10% IVS-0021 Clonal Control DNA
4-088-1250	5% IVS-0021 Clonal Control DNA
4-088-1260	1% IVS-0021 Clonal Control DNA

### IVS-0024 Clonal Control DNA

IVS-0024 Clonal Control DNA can be used as a positive control for:

Gene Rearrangements:	<i>IGH</i> , <i>IGK</i>
Chromosome Translocations:	n/c
Mutations:	n/c

This control is also available as a 5% ready-to-use dilution into a standard negative control as listed in the table below.

Catalog #	Description
4-088-1390	100% IVS-0024 Clonal Control DNA*
4-088-1430	5% IVS-0024 Clonal Control DNA

\* These controls are general purpose reagents (GPRs). All others are research use only (RUO).

† This control does not contain a complete *IGH*VH-JH rearrangement and may only be suitable for *IGH* DH-JH rearrangements.



# Controls, Reagents, and Enzymes

DNA Controls

## Cell Line DNA

### IVS-0029 Clonal Control DNA

IVS-0029 Clonal Control DNA can be used as a positive control for:

Gene Rearrangements: *IGH, IGK, IGL*  
Chromosome Translocations: n/c  
Mutations: n/c

This control is also available as several ready-to-use dilutions into a standard negative control as listed in the table below.

Catalog #	Description
4-088-1690	100% IVS-0029 Clonal Control DNA*
4-088-1700	30% IVS-0029 Clonal Control DNA
4-088-1730	5% IVS-0029 Clonal Control DNA

### *IGH* SHM Positive Control DNA

*IGH* SHM Positive Control can be used as a positive control for:

Gene Rearrangements: *IGH*  
Chromosome Translocations: n/c  
Mutations: *IGH* SHM

Catalog #	Description
4-088-0008	<i>IGH</i> SHM Positive Control DNA*

\* These controls are general purpose reagents (GPRs). All others are research use only (RUO).

### IVS-0030 Clonal Control DNA

IVS-0030 Clonal Control DNA can be used as a positive control for:

Gene Rearrangements: *IGH, IGK*  
Chromosome Translocations: *IGH-BCL2* t(14;18) Mbr  
Mutations: n/c

This control is also available as several ready-to-use dilutions into a standard negative control as listed in the table below.

Catalog #	Description
4-088-1750	100% IVS-0030 Clonal Control DNA*
4-088-1760	30% IVS-0030 Clonal Control DNA
4-088-1770	20% IVS-0030 Clonal Control DNA
4-088-1780	10% IVS-0030 Clonal Control DNA
4-088-1790	5% IVS-0030 Clonal Control DNA
4-088-1800	1% IVS-0030 Clonal Control DNA

### IVS-0031 Clonal Control DNA

IVS-0031 Clonal Control DNA can be used as a positive control for:

Gene Rearrangements: *IGH, IGK*  
Chromosome Translocations: *IGH-BCL2* t(14;18) mcr  
Mutations: n/c

This control is also available as several ready-to-use dilutions into a standard negative control as listed in the table below.

Catalog #	Description
4-088-1810	100% IVS-0031 Clonal Control DNA*
4-088-1840	10% IVS-0031 Clonal Control DNA
4-088-1860	1% IVS-0031 Clonal Control DNA

## Plasmid DNA

### Reliable Positive Controls

Plasmid DNA controls are engineered to test positive for a specific chromosome translocation or mutation using our assay master mixes. The plasmid is cloned in standard bacterial culture conditions recommended by the supplier. Our controls are tested extensively to ensure quality and reproducibility of your test results. Please note, these controls are for qualitative use only.

**Note:** These controls are assay-specific and may not generate products with other assays.

### Standard Concentrations

Plasmid IVS-P002 is diluted in IVS-0000 Polyclonal Control DNA (at 200 µg/mL in 1/10 TE) to mimic a normal background population.

### IVS-P002 Clonal Control DNA

IVS-P002 Clonal Control DNA can be used as a *IGH-BCL2* t(14;18) (3' Mbr-J<sub>H</sub>) positive control for the *BCL2*/J<sub>H</sub> Tube B master mix included in our *BCL2*/J<sub>H</sub> Translocation Assay.

Plasmid Concentration: 100 µL @ 1600 pg/mL  
Diluent: IVS-0000 Polyclonal Control DNA  
Plasmid Size: 4.06 kb

Catalog #	Description
4-090-0070	IVS-P002 Clonal Control DNA*

\* These controls are general purpose reagents (GPRs). All others are research use only (RUO).



# Low Positive Controls

Minimal Residual Disease (MRD) testing is a valuable tool that allows investigators to study and monitor multiple myeloma (MM), chronic lymphocytic leukemia (CLL), acute lymphoblastic leukemia (ALL), acute myelogenous leukemia (AML) and other hematologic diseases. Recent treatment advances have led to significantly increased clinical response and overall survival, but ultimately most subjects will relapse, driving the need for sensitive MRD monitoring. Sensitive and standardized testing such as NGS-based MRD may one day enable identification of those cases that will eventually relapse versus those who are potentially cured. In addition to the need for more sensitive tracking, it is clear that standardized methods are needed. Currently, MRD methods are highly subjective and recommendations are often based on consensus expert-shared knowledge and experience, not on a validated, objective method. Once specific rearrangements have been identified, LymphoTrack assays can be used with LymphoQuant and LymphoTrack Low Positive Controls to track these clonotype populations to a sensitivity as low as  $10^{-4}$ .

## LymphoTrack® B-cell Low Positive Control

LymphoTrack B-cell Low Positive Control can be used as a control for:

- Gene Rearrangements: *IGH, IGK*
- Chromosome Translocations: *n/c*
- Mutations: *n/c*

Catalog #	Description
4-088-0098	LymphoTrack® B-cell Low Positive Control*

## LymphoTrack® T-cell Low Positive Control

LymphoTrack T-cell Low Positive Control can be used as a control for:

- Gene Rearrangements: *TRB, TRG*
- Chromosome Translocations: *n/c*
- Mutations: *n/c*

Catalog #	Description
4-088-0108	LymphoTrack® T-cell Low Positive Control*

Note: Same product listed on page 54 in MRD Solution section.

\*LymphoTrack® Low Positive Controls are research use only (RUO), not for diagnostic procedures.



# LymphoQuant<sup>®</sup>

## Internal Controls

## Internal Controls

LymphoQuant T-cell or B-cell Internal Controls may be spiked into specimens to estimate the respective number of clonotype T-cell or B-cell equivalents present. Addition of the LymphoQuant Internal Control to the specimen PCR facilitates clonotype tracking over time without any additional sequencing cost. Consistent use of a LymphoQuant Internal Control enables investigators to objectively monitor the disease over time with a highly standardized, sensitive method. The LymphoTrack MRD software will help researchers that use the LymphoQuant Internal Control, calculate and report an estimated number of clonotype cell equivalents and the percent clonotype in the sample, enabling researchers and pharmaceutical companies to accurately monitor hematologic disease in longitudinal studies.

### LymphoQuant<sup>®</sup> B-cell Internal Control

LymphoQuant B-cell Internal Control can be used to objectively track Ig clonotypes.

Gene Rearrangements: *IGH, IGK*  
Chromosome Translocations: *n/c*  
Mutations: *n/c*

Catalog #	Description
4-088-0118	LymphoQuant <sup>®</sup> B-cell Internal Control*

### LymphoQuant<sup>®</sup> T-cell Internal Control

LymphoQuant T-cell Internal Control can be used to objectively track TCR clonotypes.

Gene Rearrangements: *TRB, TRG*  
Chromosome Translocations: *n/c*  
Mutations: *n/c*

Catalog #	Description
4-088-0128	LymphoQuant <sup>®</sup> T-cell Internal Control*

Note: Same product listed on page 55 in MRD Solution section.

\*LymphoQuant<sup>®</sup> Internal Controls are research use only (RUO), not for diagnostic procedures.

# Controls, Reagents, and Enzymes

RNA Controls

## RNA Controls

### Quick Reference for RNA Controls

#### Reliable Assay Controls

Our RNA controls are extracted from well characterized cell lines grown under standard and carefully controlled culture conditions. The controls are tested to ensure linearity and reproducible results. Since this RNA is extracted from cell lines, these controls can be used with any of the standard housekeeping genes.

#### Standard Concentrations

Each RNA single control tube (as separate control tube, RNA sensitivity panel and proficiency panel) is supplied in aliquots of 100  $\mu\text{L}$  at a final concentration of 400  $\mu\text{g}/\text{mL}$  in water. Each *BCR/ABL* RNA dilution set member is supplied in aliquots of 50  $\mu\text{L}$  at a final concentration of 400  $\mu\text{g}/\text{mL}$  in water. To ensure maximum stability, the dilution set should be stored at  $-85\text{ }^{\circ}\text{C}$  to  $-65\text{ }^{\circ}\text{C}$  and the number of freeze-thaw cycles should be kept to a minimum.

#### RNAs positive for chromosome translocations

Chromosome Translocation	Clonal Control RNA	Chromosome Translocation	Clonal Control RNA
<i>BCR-ABL1</i> t(9;22) p210 e13a2 (b2a2)	IVS-0003	<i>CBFB-MYH11</i> inv(16)	IVS-0015
<i>BCR-ABL1</i> t(9;22) p210 e14a2 (b3a2)	IVS-0011	<i>E2A-PBX1</i> t(1;19)(q23;p13)	IVS-0002
<i>BCR-ABL1</i> t(9;22) p190 e1a2	IVS-0032	<i>PML-RARA</i> t(15;17)(q22;q11)	IVS-0020

#### RNAs negative for chromosome translocations

IVS-0035 can be used as a negative control for our *BCR/ABL* t(9;22) and *PML/RARA* t(15;17) Translocation Assays.

IVS-0035 may be used as a negative control for other chromosome translocation assays, or diluents for other chromosome translocation positive controls. Please do not hesitate to contact us at [sales@invivoscribe.com](mailto:sales@invivoscribe.com) so we can evaluate whether this control may work for your testing needs.

## Cell Line RNA

### Reliable Positive and Negative Controls

Cell Line RNA controls are extracted from established cell lines grown under cell culture conditions recommended by the supplier. Our controls are tested extensively to ensure quality and reproducibility of your test results. Please note, these controls are for qualitative use only.

### Standard Concentrations

Our GMP-manufactured high-quality RNA controls, including sensitivity controls and proficiency panel samples, are supplied in aliquots of 100  $\mu$ L and are adjusted to a final concentration of 400  $\mu$ g/mL in RNase-free glass-distilled water. The pH of distilled water is slightly acidic; this protects the RNA from hydrolysis. RNA dilutions are diluted volume to volume in our negative control RNA, IVS-0035 Clonal Control RNA.

### IVS-0002 Clonal Control RNA

IVS-0002 Clonal Control RNA can be used as a positive control for the chromosome translocation: *E2A-PBX1* t(1;19) (q23;p13).

Catalog #	Description
4-089-0100	IVS-0002 Clonal Control RNA*

### IVS-0003 Clonal Control RNA

IVS-0003 Clonal Control RNA can be used as a positive control for the chromosome translocation: *BCR-ABL1* t(9;22) p210 e13a2 (b2a2).

This control is also available as several ready-to-use dilutions into a standard negative control as listed in the table below.

Catalog #	Description
4-089-0190	IVS-0003 Clonal Control RNA*
4-089-0200	10 <sup>-1</sup> IVS-0003 Clonal Control RNA
4-089-0210	10 <sup>-2</sup> IVS-0003 Clonal Control RNA
4-089-0220	10 <sup>-3</sup> IVS-0003 Clonal Control RNA
4-089-0230	10 <sup>-4</sup> IVS-0003 Clonal Control RNA
4-089-0240	10 <sup>-5</sup> IVS-0003 Clonal Control RNA
4-089-0250	10 <sup>-6</sup> IVS-0003 Clonal Control RNA

### IVS-0011 Clonal Control RNA

IVS-0011 Clonal Control RNA can be used as a positive control for the chromosome translocation: *BCR-ABL1* t(9;22) p210 e14a2 (b3a2).

This control is also available as several ready-to-use dilutions into a standard negative control as listed in the table below.

Catalog #	Description
4-089-0910	IVS-0011 Clonal Control RNA*
4-089-0920	10 <sup>-1</sup> IVS-0011 Clonal Control RNA
4-089-0930	10 <sup>-2</sup> IVS-0011 Clonal Control RNA
4-089-0940	10 <sup>-3</sup> IVS-0011 Clonal Control RNA
4-089-0950	10 <sup>-4</sup> IVS-0011 Clonal Control RNA
4-089-0960	10 <sup>-5</sup> IVS-0011 Clonal Control RNA

### IVS-0015 Clonal Control RNA

IVS-0015 Clonal Control RNA can be used as a positive control for the chromosome translocation: *CBFB-MYH11* inv(16)

Catalog #	Description
4-089-1270	IVS-0015 Clonal Control RNA*

### IVS-0020 Clonal Control RNA

IVS-0020 Clonal Control RNA can be used as a positive control for the chromosome translocation: *PML-RARA* t(15;17) L-Form.

This control is also available as several ready-to-use dilutions into a standard negative control as listed in the table below.

Catalog #	Description
4-089-1720	IVS-0020 Clonal Control RNA*
4-089-1730	10 <sup>-1</sup> IVS-0020 Clonal Control RNA
4-089-1740	10 <sup>-2</sup> IVS-0020 Clonal Control RNA
4-089-1750	10 <sup>-3</sup> IVS-0020 Clonal Control RNA
4-089-1760	10 <sup>-4</sup> IVS-0020 Clonal Control RNA

### IVS-0032 Clonal Control RNA

IVS-0032 Clonal Control RNA can be used as a positive control for the chromosome translocation: *BCR-ABL1* t(9;22) p190 e1a2.

This control is also available as several ready-to-use dilutions into a standard negative control as listed in the table below.

Catalog #	Description
4-089-2800	IVS-0032 Clonal Control RNA*
4-089-2810	10 <sup>-1</sup> IVS-0032 Clonal Control RNA
4-089-2820	10 <sup>-2</sup> IVS-0032 Clonal Control RNA
4-089-2830	10 <sup>-3</sup> IVS-0032 Clonal Control RNA
4-089-2840	10 <sup>-4</sup> IVS-0032 Clonal Control RNA
4-089-2850	10 <sup>-5</sup> IVS-0032 Clonal Control RNA
4-089-2860	10 <sup>-6</sup> IVS-0032 Clonal Control RNA

### IVS-0035 Clonal Control RNA

IVS-0035 Clonal Control RNA can be used as a negative control for our *BCR/ABL1* t(9;22) and *PML/RARA* t(15;17) Translocation Assays.

Catalog #	Description
4-089-3070	IVS-0035 Clonal Control RNA*

\* These controls are general purpose reagents (GPRs). All others are research use only (RUO).

# Controls, Reagents, and Enzymes

## BCR/ABL RNA Dilution Sets

Our *BCR/ABL* b2a2, b3a2, and e1a2 RNA Dilution Sets consist of RNA that has been extracted from *BCR-ABL1* expressing and *BCR-ABL1* negative cell lines. Each set is composed of several dilutions ( $10^{-1}$ ,  $10^{-2}$ ,  $10^{-3}$ ,  $10^{-4}$ ,  $10^{-5}$ ) of the *BCR-ABL1* positive RNA diluted (v/v) into RNA purified from a cell line that does not contain a *BCR-ABL1* translocation. Also included in these sets is a 100% *BCR-ABL1* negative RNA.

The individual *BCR/ABL* b2a2, b3a2, and e1a2 RNA Dilution Sets can be used as reference and validation materials with assays that target

the main transcripts of *BCR-ABL1* t(9;22) translocations: p210 (e13a2 (b2a2), e14a2 (b3a2), and p190 (e1a2)). These products may be used as the following:

- Routine testing controls for cDNA synthesis, amplification and detection
- Controls to establish a standard reference curve
- Proficiency controls
- Sensitivity controls for specific target assays

## Data

Plot of Ct values (5 replicates) for the  $10^{-1}$ ,  $10^{-2}$ ,  $10^{-3}$ ,  $10^{-4}$ , and  $10^{-5}$  dilutions.

### Ordering Information - e14a2 (b3a2)

Catalog #	Description
4-085-0210	<i>BCR/ABL</i> b3a2 RNA Dilution Set ( $10^{-1}$ , $10^{-2}$ , $10^{-3}$ , $10^{-4}$ , $10^{-5}$ dilutions and negative)

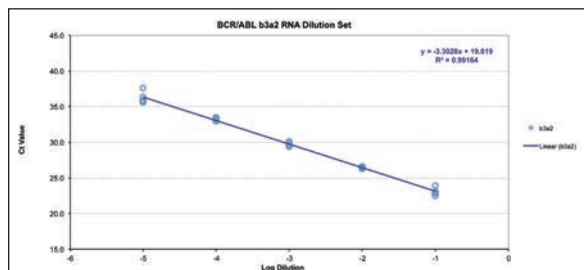

### Ordering Information - e13a2 (b2a2)

Catalog #	Description
4-085-0310	<i>BCR/ABL</i> b2a2 RNA Dilution Set ( $10^{-1}$ , $10^{-2}$ , $10^{-3}$ , $10^{-4}$ , $10^{-5}$ dilutions and negative)

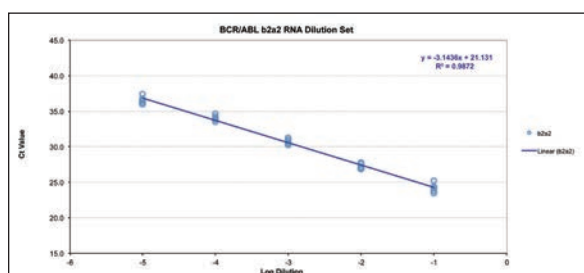

### Ordering Information - e1a2

Catalog #	Description
4-085-0110	<i>BCR/ABL</i> e1a2 RNA Dilution Set ( $10^{-1}$ , $10^{-2}$ , $10^{-3}$ , $10^{-4}$ , $10^{-5}$ dilutions and negative)

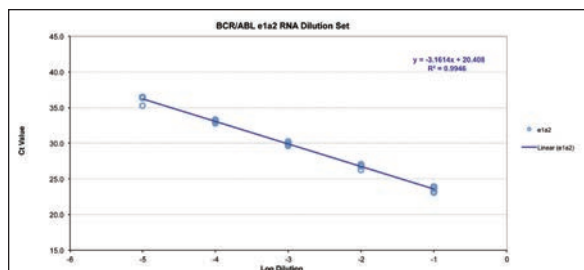

These controls are research use only (RUO), not for diagnostic procedures.



## Control Panels

### DNA and RNA Sensitivity Panels

#### DNA Sensitivity Panels

DNA sensitivity panels are 6 member panels that consist of 100% clonal DNA extracted from a positive control cell line and 30%, 20%, 10%, 5%, and 1% dilutions of the positive clonal DNA diluted (v/v) into our standard negative control DNA, IVS-0000 Polyclonal Control DNA. Each tube contains 100  $\mu$ L of DNA at a concentration of 200  $\mu$ g/mL in 1/10 TE buffer (1 mM Tris-HCl pH 8.0, 0.1 mM EDTA). This diluent provides sufficient buffering capacity and EDTA to protect the DNA controls without interfering with the  $Mg^{2+}$  concentrations required for robust amplification reactions. Please note, these controls are for qualitative use only.

#### RNA Sensitivity Panels

RNA sensitivity panels are 7 member panels that consist of 100% clonal RNA extracted from a positive control cell line and  $10^{-1}$ ,  $10^{-2}$ ,  $10^{-3}$ ,  $10^{-4}$ ,  $10^{-5}$ , and  $10^{-6}$  (1:10 - 1:1 000 000) dilutions of the positive clonal RNA diluted (v/v) into our standard negative control RNA, IVS-0035 Clonal Control RNA. Each tube contains 100  $\mu$ L of RNA at 400  $\mu$ g/mL in RNase-free glass-distilled water. The pH of distilled water is slightly acidic thereby protecting the RNA from hydrolysis. Please note, these controls are for qualitative use only.

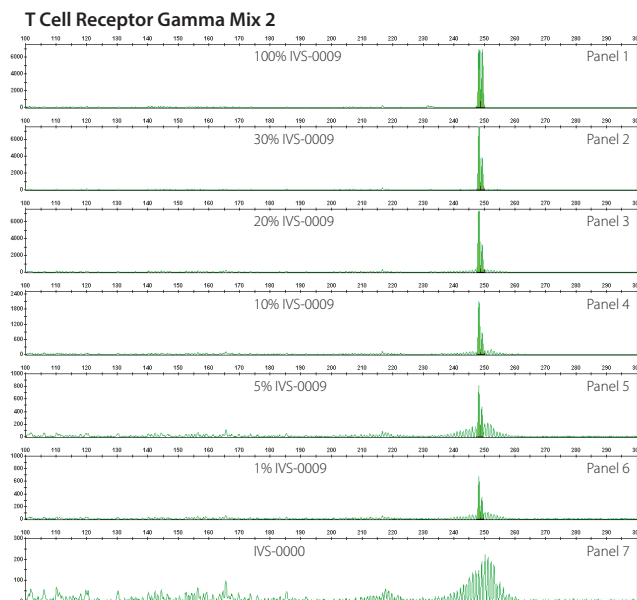
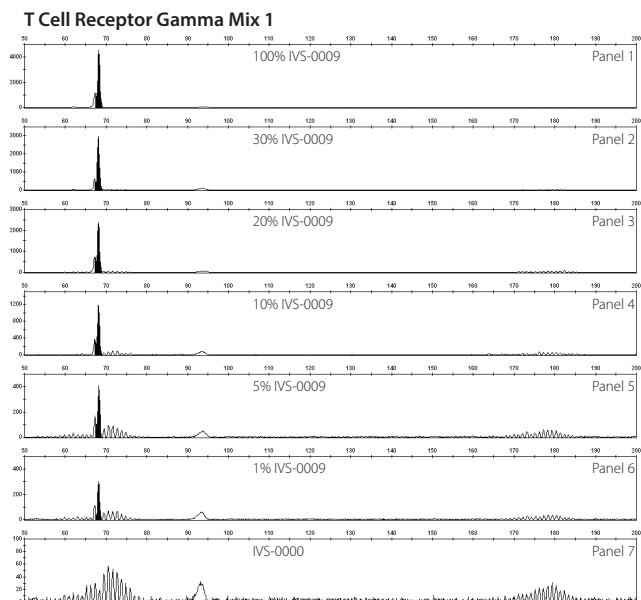

This data was generated testing a Sensitivity Panel for IVS-0009 Clonal Control DNA using the master mixes listed. PCR products were run on an ABI 3130xL capillary electrophoresis instrument for differential fluorescence detection and data analyses. Panel 7 shows the polyclonal Gaussian distributions expected from our negative control IVS-0000 Polyclonal Control DNA. Data in the other panels are tests of positive control samples at the dilutions indicated. Clonal peaks (highlighted) are clearly evident in all of the positive sample panels.

These products are research use only (RUO), not for diagnostic procedures.



# Controls, Reagents, and Enzymes

DNA and RNA Sensitivity Panels and Proficiency Panels

## DNA Sensitivity Panels

Catalog #	Description	Can be used as a positive control for:
4-086-0040	Sensitivity Panel for IVS-0004 Clonal Control DNA	<i>TRB, TRG</i>
4-086-0070	Sensitivity Panel for IVS-0007 Clonal Control DNA	<i>IGH, IGK, IGL, IGH-BCL2 t(14;18) Mbr</i>
4-086-0090	Sensitivity Panel for IVS-0009 Clonal Control DNA	<i>TRB, TRG</i>
4-086-0100	Sensitivity Panel for IVS-0010 Clonal Control DNA	<i>IGH, IGK, IGL, IGH-CCND1 t(11;14)</i>
4-086-0190	Sensitivity Panel for IVS-0019 Clonal Control DNA	<i>IGH, IGK</i>
4-086-0210	Sensitivity Panel for IVS-0021 Clonal Control DNA	<i>TRB, TRD, TRG</i>
4-086-0300	Sensitivity Panel for IVS-0030 Clonal Control DNA	<i>IGH, IGK, IGH-BCL2 t(14;18) Mbr</i>

## RNA Sensitivity Panels

Catalog #	Description	Can be used as a positive control for:
4-087-0030	Sensitivity Panel for IVS-0003 Clonal Control RNA	<i>BCR-ABL1 t(9;22) p210 e13a2 (b2a2)</i>
4-087-0110	Sensitivity Panel for IVS-0011 Clonal Control RNA	<i>BCR-ABL1 t(9;22) p210 e14a2 (b3a2)</i>
4-087-0150	Sensitivity Panel for IVS-0015 Clonal Control RNA	<i>CBFB/MYH11 inv16</i>
4-087-0200	Sensitivity Panel for IVS-0020 Clonal Control RNA	<i>PML-RARA t(15;17) L-form</i>
4-087-0320	Sensitivity Panel for IVS-0032 Clonal Control RNA	<i>BCR-ABL1 t(9;22) p190 e1a2</i>

## Proficiency Panel for *BCR-ABL1 t(9;22)*

This 10 member panel consists of 100% clonal control RNA extracted from three *BCR-ABL1* positive cell lines as well as  $10^{-2}$  (1:100) and  $10^{-4}$  (1:10,000) dilutions (v/v) of these positive RNAs diluted into a normal (*BCR-ABL1* negative) control RNA, IVS-0035 Clonal Control RNA.

A sample of 100% IVS-0035 Clonal Control RNA is also included. All three cell lines (IVS-0003, IVS-0011, and IVS-0032) carry a t(9;22) translocation. One of the cell lines, IVS-0032, encodes for p190-type

(ALL-associated) transcript with e1a2 junctions. The other two cell lines both encode for p210-type (CML-associated) transcripts. One of the p210-type translocations, IVS-0003, harbors a e13a2 (b2a2) junction and the other, IVS-0011, harbors a e14a2 (b3a2) junction.

This proficiency panel is used to validate tests that identify *BCR-ABL1 t(9;22)* translocations and is designed to be used with the *BCR/ABL t(9;22)* Translocation Assay Kits.

## RNA Proficiency Panel

Qty	Description	Chromosome Translocation
1	IVS-0003 Clonal Control RNA $10^{-2}$ IVS-0003 Clonal Control RNA $10^{-4}$ IVS-0003 Clonal Control RNA	<i>BCR-ABL1</i> p210 e13a2 (b2a2)
1	IVS-0011 Clonal Control RNA $10^{-2}$ IVS-0011 Clonal Control RNA $10^{-4}$ IVS-0011 Clonal Control RNA	<i>BCR-ABL1</i> p210 e14a2 (b3a2)
1	IVS-0032 Clonal Control RNA $10^{-2}$ IVS-0032 Clonal Control RNA $10^{-4}$ IVS-0032 Clonal Control RNA	<i>BCR-ABL1</i> p190 e1a2
1	IVS-0035 Clonal Control RNA	<i>BCR-ABL1</i> Negative

## Ordering Information

Catalog #	Description
4-310-0100	Proficiency Panel for the <i>BCR/ABL t(9;22)</i> Translocation Assay

These products are research use only (RUO), not for diagnostic procedures.

# Controls, Reagents, and Enzymes

Master Mix Controls

## Master Mix Controls

These master mixes serve as control for many of our DNA assays to ensure that sample DNA is of sufficient quality and integrity to generate a valid result.

### Amplification Control Master Mix

Our Amplification Control master mix targets the *HLA-DQa* locus and generates a product of 235 basepairs in size from human genomic DNA. This control is available in unlabeled (for Gel Detection) and fluorescence labeled format (for ABI Fluorescence Detection, 6FAM).

Catalog #	Description
2-096-0010	Amplification Control Master Mix - Unlabeled*
2-096-0011	Amplification Control Master Mix - 6FAM*

### Specimen Control Size Ladder

Our Specimen Control Size Ladder master mix targets four different housekeeping genes producing products of approximately 100, 200, 300, 400, and 600 basepairs in size to ensure that the quality and quantity of the sample DNA is adequate to yield a valid result with the specific assay(s).

This master mix is based on the BIOMED-2 Concerted Action BMH4-CT98-3936 from the EuroClonality Group and is available for Gel Detection (unlabeled) or ABI detection (labeled with 6FAM).

Catalog #	Description
2-096-0020	Specimen Control Size Ladder - Unlabeled*
2-096-0021	Specimen Control Size Ladder - 6FAM*

\*These master mixes are general purpose reagents (GPRs).





## Reagents

### ABI Detection Reagents

#### Reagents for ABI Fluorescence Detection

Invivoscribe also offers highly deionized (Hi-Di) Formamide with ROX size standards for ABI fluorescence detection with the ABI 310 or 3100 series. Hi-Di Formamide is used to stabilize single strands of denatured PCR amplicons. The ROX size standards are fluorescent labeled DNA standards which cover the 50 to 400 basepair size range. Sizes of the individual standards are: 50, 60, 90, 100, 120, 150, 160, 180, 190, 200, 220, 240, 260, 280, 290, 300, 320, 340, 360, 380, and 400 basepairs.

For samples tested on an ABI 310 or 3100 series, we recommend using 10  $\mu\text{L}$  of the Hi-Deionized Formamide with ROX Size Standards mixture for each microliter of PCR product. Please note that the ABI 310 and 3100 series require different concentrations of ROX size standards and the different Hi-Deionized Formamide with ROX Size Standards cannot be used interchangeably.

For samples tested on an ABI 3500 series, GeneScan™ 600® LIZ dye Size Standard v2.0 can be purchased from Thermo Fisher Scientific.

#### Ordering Information

Catalog #	Description
6-098-0051	Hi-Deionized Formamide with ROX Size Standard (ABI 310), 1 mL
6-098-0061	Hi-Deionized Formamide with ROX Size Standard (ABI 3100), 1 mL
Available through Thermo Fisher Scientific®: 4408399	GeneScan™ 600 LIZ® dye v2.0 Standard (ABI 3500), 800 reactions

For research use only (RUO), not for diagnostic procedures.

## Enzymes

### EagleTaq DNA Polymerase

Note: This product is for sale and use in the European Economic Area only. It is not to be resold or transferred to another party. See also Notice on page 132.

#### EagleTaq DNA Polymerase

EagleTaq DNA Polymerase can be used to obtain highly specific and sensitive PCR amplification products. This enzyme has been proven to minimize extension of non-specifically bound primers. Obtain reliable results by using the gold standard of hot start polymerases for robust performance.

#### Ordering Information

Catalog #	Description
6-097-0100	EagleTaq DNA Polymerase 1000 U, 5 U/ $\mu\text{L}$

For research use only (RUO), not for diagnostic procedures.

# Custom Products

## WARRANTY AND LIABILITY

Invivoscribe, Inc. (Invivoscribe®) is committed to providing the highest quality products. Invivoscribe® warrants that the products meet or exceed the performance standards described in the Instructions For Use, as to products with such an insert. If a product is covered by product specifications and does not perform as specified, our policy is to replace the product or credit the full purchase price. No other warranties of any kind, expressed or implied, are provided by Invivoscribe®. Invivoscribe® liability shall not exceed the purchase price of the product. Invivoscribe shall have no liability for direct, indirect, consequential, or incidental damages arising from the use, results of use, or inability to use its products; product efficacy under purchaser controlled conditions in purchaser's laboratory must be established and continually monitored through purchaser defined and controlled processes including but not limited to testing of positive, negative, and blank controls every time a sample is tested. Ordering, acceptance, and use of product constitutes purchaser acceptance of sole responsibility for assuring product efficacy and purchaser agreement to the limitation of liability set forth in this paragraph.

# Custom Products

## Customized Products to Meet Your Needs

The Invivoscribe team of experts can help develop your ideas into customized products. Allow us to partner with you to take a basic concept through design, development, validation, regulatory approval (if applicable), and release. For more information, please call our San Diego office at +1 858.224.6600 or send an e-mail to [sales@invivoscribe.com](mailto:sales@invivoscribe.com).

## Custom Designed Assays

In response to the FDA announcing its intention to dramatically expand its regulatory oversight of laboratory developed tests (LDTs), Invivoscribe is partnering with laboratories worldwide to help facilitate the conversion of LDTs into FDA-cleared assays, as we know the barriers to bringing new assays online are often the availability of resources and the cost of validation.

By leveraging the power of our regulatory expertise, provided through each milestone, we can help ensure safety, efficacy and quality. Our customizable reagent manufacturing capabilities can reduce your LDT costs and lead to higher-quality testing.

To date, we have partnered with more than 40 laboratories around the world to develop, validate, and launch a variety of molecular products. A number of these partnerships have also led to the release of US and CE-marked *in vitro* diagnostic products and services. Learn how Invivoscribe can help you develop assays for new products, services, and novel applications.

## Custom Controls and Validation Panels

We offer a large selection of well-characterized DNA and RNA controls that are used to define the performance characteristics of a wide variety of molecular reagents. To address your specific requirements, we can partner with you to design, validate, and provide custom controls and validation panels. If necessary, we are willing to acquire, characterize, and engineer custom controls for your specific application. We can produce DNA, RNA, or cDNA at any specified concentration, dilution, or volume. Please contact us with your requirements and we will be happy to provide controls to suit your needs.

## Invivoscribe is a Comprehensive Partner for Companion Diagnostic Development

From biomarker identification through commercialization, Invivoscribe has expertise at every stage of companion diagnostics development.

- **Discovery & Patient Stratification:** We offer comprehensive gene panels to identify biomarkers and define patient populations, thus reducing development costs and improving the success of clinical trials.
- **Clinical Trials:** Our network of global laboratories accelerates sample acquisition and harmonizes testing to ensure accurate results.

- **Regulatory Approval:** Our in-house experts have experience seeking approval with global agencies.
- **Commercialization:** Our cGMP manufacturing expertise and distribution channels allow approved CDx to reach all global markets.

Invivoscribe is an ISO 13485-accredited and FDA/CDRH registered medical device manufacturer with a long record of successful partnerships. We are the industry-leading assay and software development company, providing full QSR design control and a complete range of cGMP manufactured assays, controls, reagents, and services to CLIA-accredited clinical laboratory and pharmaceutical communities.

Please contact us at +1 858.224.6600 or [sales@invivoscribe.com](mailto:sales@invivoscribe.com) for more details about partnering with Invivoscribe for the development and manufacturing of companion diagnostics, *in vitro* diagnostics, molecular reagents, and/or nucleic acid controls.

#### WARRANTY AND LIABILITY

Invivoscribe, Inc. (Invivoscribe®) is committed to providing the highest quality products. Invivoscribe® warrants that the products meet or exceed the performance standards described in the Instructions For Use, as to products with such an insert. If a product is covered by product specifications and does not perform as specified, our policy is to replace the product or credit the full purchase price. No other warranties of any kind, expressed or implied, are provided by Invivoscribe®. Invivoscribe® liability shall not exceed the purchase price of the product. Invivoscribe® shall have no liability for direct, indirect, consequential, or incidental damages arising from the use, results of use, or inability to use its products; product efficacy under purchaser controlled conditions in purchaser's laboratory must be established and continually monitored through purchaser defined and controlled processes including but not limited to testing of positive, negative, and blank controls every time a sample is tested. Ordering, acceptance, and use of product constitutes purchaser acceptance of sole responsibility for assuring product efficacy and purchaser agreement to the limitation of liability set forth in this paragraph.

# Reference

The Invivoscribe European Conformity marked *in vitro* diagnostics (CE-IVD) and Research Use Only (RUO) clonality assays detect clonal populations in just a few easy steps. These steps include PCR amplification of the immunoglobulin or T-cell receptor genes of interest, followed by detection with non-denaturing polyacrylamide gels, capillary electrophoresis, or next-generation sequencing using an Illumina® MiSeq®, Thermo Fisher Scientific® Ion S5™ or PGM™ instrument. A flowchart illustrating this workflow is shown below.

## Clonality Testing Workflow

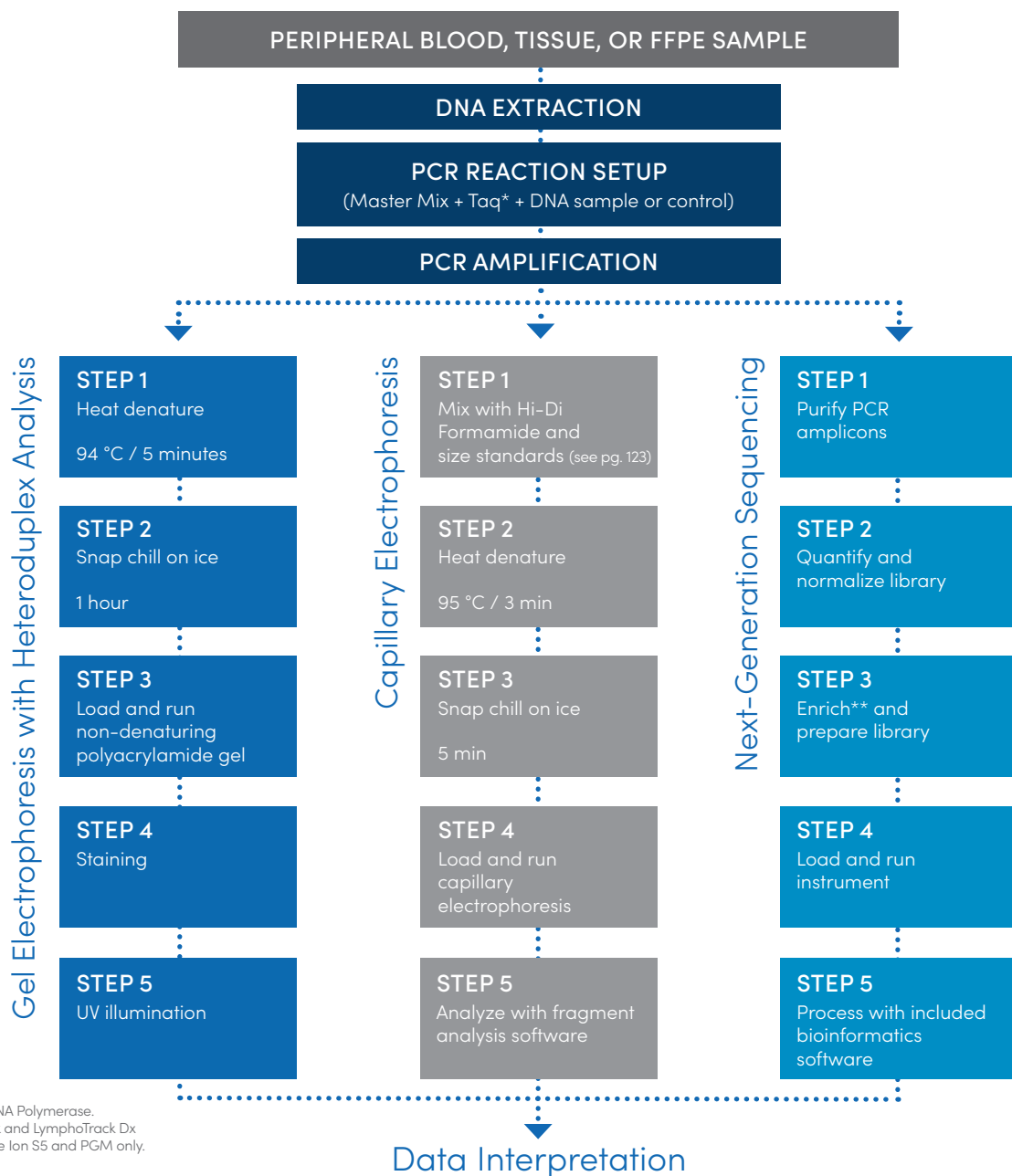

\*Or equivalent DNA Polymerase.  
\*\* For LymphoTrack and LymphoTrack Dx Assays run on the Ion S5 and PGM only.

CE-marked *in vitro* diagnostic products are not available for sale or use within North America.

# LymphoTrack Dx and LymphoTrack Workflow Summary

illumina® MiSeq®

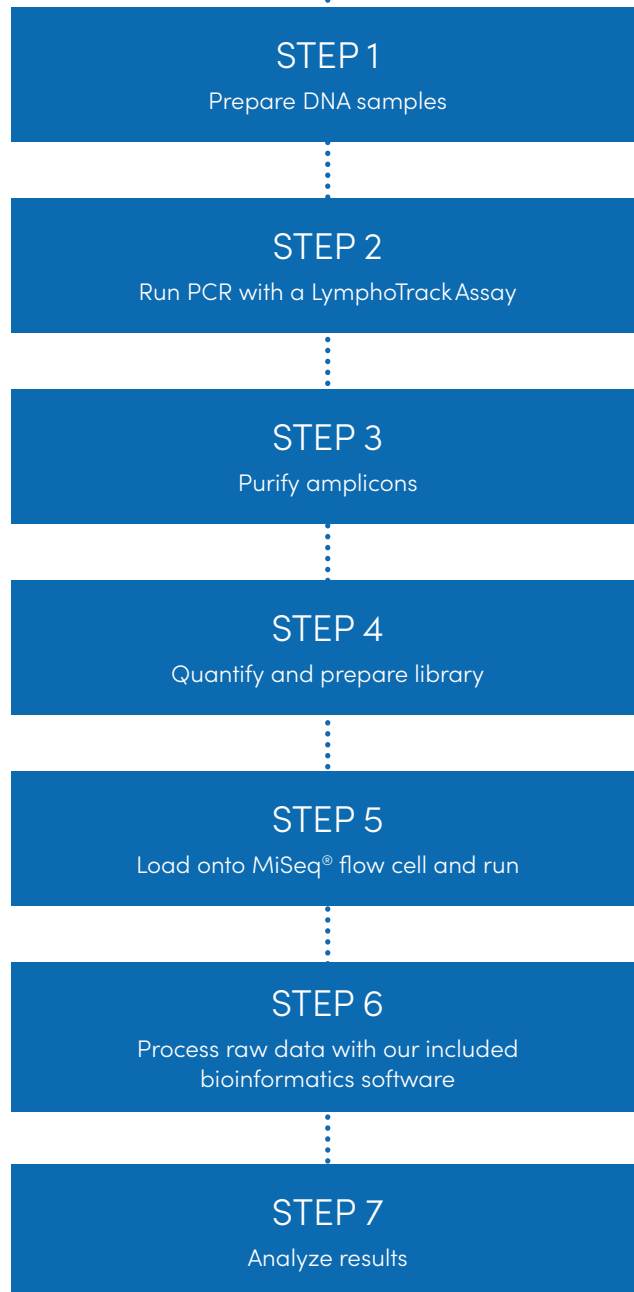

NOTICE: The LymphoTrack Dx Assays are *in vitro* diagnostic products and are not available for sale or use within North America.

\*Image courtesy of Illumina, Inc.



# LymphoTrack Dx and LymphoTrack Workflow Summary

## Thermo Fisher Scientific® Ion S5/PGM™

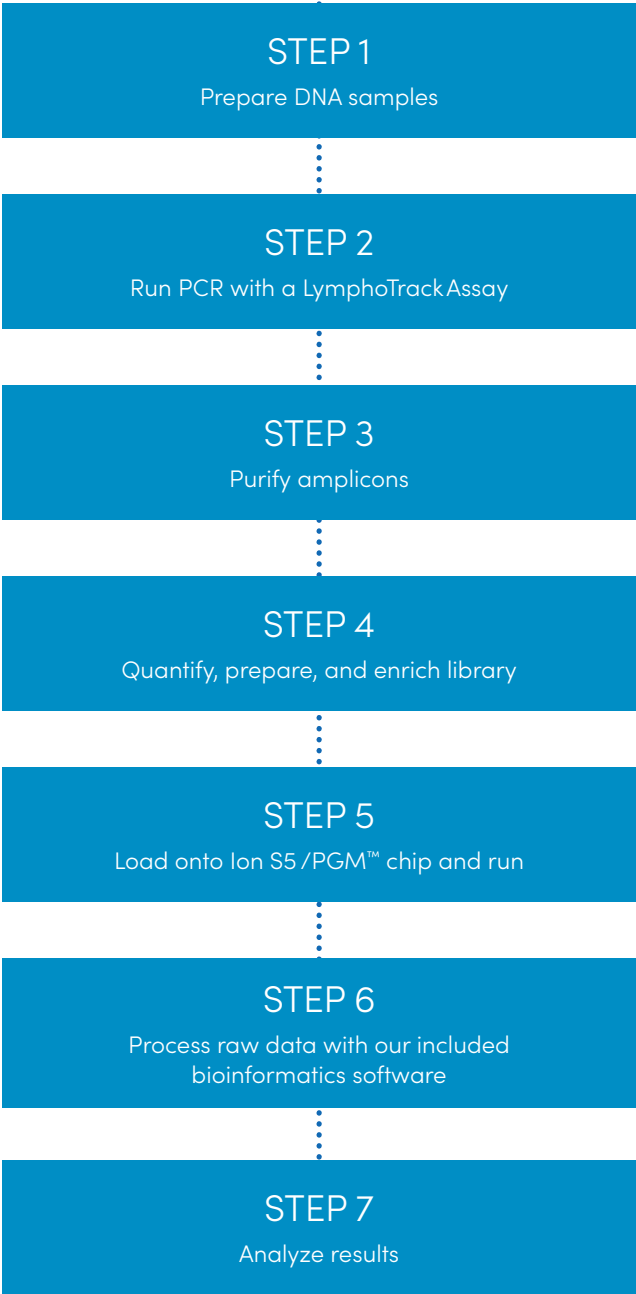

NOTICE: The LymphoTrack Dx Assays are *in vitro* diagnostic products and are not available for sale or use within North America.

\*Image courtesy of Thermo Fisher Scientific

# Next-Generation Sequencing Menu

Invivoscribe offers LymphoTrack and LymphoTrack Dx Assays for the analysis of B- and T-cell clonality, somatic hypermutation, and minimal residual disease studies\*\*. Assays are designed for use on both industry standard next-generation sequencing (NGS) platforms: the Illumina® MiSeq® and Thermo Fisher Scientific® Ion PGM™ and Ion S5™ instruments.

Invivoscribe assays for the Illumina® MiSeq® platform offer the ability to analyze up to twenty two samples and two controls per gene target and the multiplexing capabilities to generate a sequencing library that combines amplicons from different Invivoscribe LymphoTrack and LymphoTrack Dx Assays onto the same flow cell. Our included software then sorts and assigns the correct sequences to their corresponding sample.

Invivoscribe assays for the Ion PGM™ and Ion S5™ platform offer the ability to analyze up to ten samples and two controls per gene target

and the multiplexing capability to generate a sequencing library that combines amplicons from different Invivoscribe LymphoTrack and LymphoTrack Dx Assays onto the same sequencing chip, reducing per sample testing costs.

All LymphoTrack and LymphoTrack Dx Assays allow for fast and easy analysis and data visualization using the included bioinformatics software. The LymphoTrack software sorts and assigns the sequences to their corresponding sample and provides information such as the prevalence, gene segment usage, and the mutation rate (*IGH* Leader and *IGH* FR1 only). In addition, the Invivoscribe Minimal Residual Disease (MRD) Software allows for clonotype sequences to be tracked in subsequent samples for research applications.

The table below indicates which LymphoTrack (Research Use Only) and LymphoTrack Dx (CE-IVD Marked) Assays are currently available in 2020.

CE-Marked IVD Assays	MiSeq®	Ion S5/PGM™
LymphoTrack® Dx <i>IGHV</i> Leader Somatic Hypermutation Assays	AVAILABLE	NOT AVAILABLE
LymphoTrack® Dx <i>IGH</i> FR1 Assays	AVAILABLE	AVAILABLE
LymphoTrack® Dx <i>IGH</i> FR2 Assays	AVAILABLE	AVAILABLE
LymphoTrack® Dx <i>IGH</i> FR3 Assays	AVAILABLE	AVAILABLE
LymphoTrack® Dx <i>IGH</i> FR1/2/3 Assays	AVAILABLE	AVAILABLE
LymphoTrack® Dx <i>IGK</i> Assays	AVAILABLE	AVAILABLE
LymphoTrack® Dx <i>TRG</i> Assays	AVAILABLE	AVAILABLE
LymphoTrack® Dx <i>TRB</i> Assays	AVAILABLE	PLEASE INQUIRE
Research Use Only (RUO) Assays	MiSeq®	Ion S5/PGM™
LymphoTrack® <i>IGHV</i> Somatic Hypermutation Assays	AVAILABLE	PLEASE INQUIRE
LymphoTrack® <i>IGH</i> FR1 Assays	AVAILABLE	AVAILABLE
LymphoTrack® <i>IGH</i> FR2 Assays	AVAILABLE	AVAILABLE
LymphoTrack® <i>IGH</i> FR3 Assays	AVAILABLE	AVAILABLE
LymphoTrack® <i>IGH</i> FR1/2/3 Assays	AVAILABLE	AVAILABLE
LymphoTrack® <i>IGK</i> Assays	AVAILABLE	AVAILABLE
LymphoTrack® <i>TRG</i> Assays	AVAILABLE	AVAILABLE
LymphoTrack® <i>TRB</i> Assay	AVAILABLE	PLEASE INQUIRE

CE-marked assays are *in vitro* diagnostic products and are not available for sale or use within North America.

\*\*Minimal residual disease (MRD) applications are currently for research use only.

# Gel and Capillary Electrophoresis Menu

Inivoscribe offers assays that can be analyzed using two conventional methods of fragment analysis: gel electrophoresis or capillary electrophoresis.

Gel electrophoresis kits offer a comparatively easy and inexpensive solution for clonality, translocation, and mutational testing and are often the method of choice for laboratories new to using these methods and techniques. PCR products are analyzed using non-denaturing polyacrylamide gels (PAGE) and often require a heteroduplex step for resolution of generated amplicons.

Capillary electrophoresis kits are supplied with fluorescently labeled primers, allowing the resulting PCR products to be analyzed on Applied Biosystems (ABI) platforms (e.g. 3130, 3500). Fragment analysis by capillary electrophoresis offers the ability to detect fragments with a high level of accuracy and analytical sensitivity and allows for greater sample throughput compared to gel detection methods. In addition, capillary electrophoresis detection often facilitates a more objective interpretation of results than gel-based detection.

The table below summarizes which detection methods are available for our clonality and translocation assays either as Research Use Only or CE-marked IVDs.

CE-Marked IVD Assays	Gel	ABI
IdentiClone® <i>IGH + IGK</i> B-Cell Clonality Assay	AVAILABLE	AVAILABLE
IdentiClone® <i>IGH</i> Gene Clonality Assay	AVAILABLE	AVAILABLE
IdentiClone® <i>IGK</i> Gene Clonality Assay	AVAILABLE	AVAILABLE
IdentiClone® <i>IGL</i> Gene Clonality Assay	AVAILABLE	AVAILABLE
IdentiClone® <i>TCRB + TCRG</i> T-Cell Clonality Assay	AVAILABLE	AVAILABLE
IdentiClone® <i>TCRB</i> Gene Clonality Assay	AVAILABLE	AVAILABLE
IdentiClone® T-Cell Receptor Gamma Gene Rearrangement Assay 2.0	NOT AVAILABLE	AVAILABLE
IdentiClone® <i>TCRG</i> Gene Clonality Assay	AVAILABLE	AVAILABLE
IdentiClone® <i>TCRD</i> Gene Clonality Assay	AVAILABLE	AVAILABLE
IdentiClone® <i>BCL1/JH</i> Translocation Assay	AVAILABLE	NOT AVAILABLE
IdentiClone® <i>BCL2/JH</i> Translocation Assay	AVAILABLE	NOT AVAILABLE
Research Use Only (RUO) Assays	Gel	ABI
<i>IGH + IGK</i> B-Cell Clonality Assay	AVAILABLE	AVAILABLE
<i>IGH</i> Gene Rearrangement Assay	AVAILABLE	AVAILABLE
<i>IGH</i> Gene Clonality Assay	AVAILABLE	AVAILABLE
<i>IGH</i> Somatic Hypermutation Assay v2.0	AVAILABLE	AVAILABLE
<i>IGL</i> Gene Clonality Assay	AVAILABLE	AVAILABLE
<i>TCRB + TCRG</i> T-Cell Clonality Assay	AVAILABLE	AVAILABLE
<i>TCRB</i> Gene Clonality Assay	AVAILABLE	AVAILABLE
T-Cell Receptor Gamma Gene Rearrangement Assay	AVAILABLE	AVAILABLE
T-Cell Receptor Gamma Gene Rearrangement Assay 2.0	NOT AVAILABLE	AVAILABLE
<i>TCRG</i> Gene Clonality Assay	AVAILABLE	AVAILABLE
<i>TCRD</i> Gene Clonality Assay	AVAILABLE	AVAILABLE
<i>BCL1/JH</i> Translocation Assay	AVAILABLE	NOT AVAILABLE
<i>BCL2/JH</i> Translocation Assay	AVAILABLE	NOT AVAILABLE
<i>BCL2/JH</i> t(14;18) Translocation Assay	AVAILABLE	NOT AVAILABLE
<i>BCR/ABL</i> t(9;22) Translocation Assay	AVAILABLE	AVAILABLE
<i>PML/RARA</i> t(15;17) Translocation Assay	AVAILABLE	AVAILABLE

CE-marked assays are *in vitro* diagnostic products and are not available for sale or use within North America.

# Common Technical Support Questions

1. **What sample types may be suitable for analysis with Invivoscribe Gel and Capillary assays?**

We recommend high-quality DNA for clonality testing with our assays. This can be extracted from frozen or fresh tissue, peripheral blood, bone marrow, skin biopsies, etc.

2. **When should the recommended controls be run with our assays?**

The no template, positive, and negative controls should be included in every run for each target, per the product insert or instructions for use.

3. **What is the purpose of the Specimen Control Size Ladder and Amplification Control master mix? What is the difference between these master mixes?**

The Specimen Control Size Ladder and Amplification Control master mixes are used as troubleshooting tools that allow you to determine if the quality and quantity of your DNA sample is suitable for use with our assays. The Specimen Control Size Ladder amplifies DNA at approximately 100, 200, 300, 400, and 600 base pairs; whereas, the Amplification Control amplifies DNA at 235 bp.

4. **How should the master mix and controls be stored and thawed?**

The master mixes should be stored at -65 to -85 °C and should be thawed at room temperature and vortexed prior to use. If you intend to use master mixes multiple times, we recommend aliquoting the master mixes to minimize the number of freeze/thaw cycles. For the *FLT3* CDx Mutation Assay: Opened vials of master mixes stored frozen may incur up to 4 freeze thaw cycles. Opened vials of controls stored frozen may incur up to 8 freeze thaw cycles.

5. **Where can more information about the primers used in our assays be found?**

Most primer information is proprietary to Invivoscribe and cannot be disclosed. We can, however, tell you the target area for the primers in each master mix, if you contact our support team by emailing [support@invivoscribe.com](mailto:support@invivoscribe.com) or by calling +1 858-224-6600.

6. **Which targets are recommended for the study of B-cell malignancies?**

The EuroClonality/BIOMED-2 Group has shown that combined testing of *IGH* and *IGK* achieves a clinical sensitivity of 99%. If purchasing these assays separately is cost prohibitive, our *IGH* + *IGK* Gene Clonality Assay (does not include *IGH* Tubes D and E) may be a feasible alternative option (see Figure 2 and Table 1 in *Leukemia* (2007) 21, 201-206). We also offer next-generation sequencing LymphoTrack® Assays for *IGH* and *IGK* for use with MiSeq® or Ion S5/PGM™ instruments. In addition, a high percentage of B-ALL patients have *TRG* rearrangements, which can be detected using our assays to detect *TRG* gene rearrangements.

7. **What are the differences between our *IGH* Gene Rearrangement Assays and the *IGH* Gene Clonality Assays?**

The *IGH* Gene Rearrangement Assay was designed by Invivoscribe; whereas, the *IGH* Gene Clonality Assay was designed by the EuroClonality/BIOMED-2 Group. Both assays target the conserved *IGH* framework regions, Framework 1, Framework 2, and Framework 3. The *IGH* Gene Clonality Assay also targets incomplete *D<sub>H</sub> - J<sub>H</sub>* rearrangements. The *IGH* Gene Clonality Assay includes 33 reactions per master mix and the *IGH* Gene Rearrangement Assay includes 30 reactions per master mix.

8. **What do *IGH* Tubes D and E target do and why are they challenging to interpret?**

Tubes D and E of our *IGH* Gene Clonality Assays target incomplete *IGH* *D<sub>H</sub> - J<sub>H</sub>* rearrangements. It is common to see known amplicons listed in the instructions for use in cases where a polyclonal background is absent (this is likely because these rearrangements are rare). Some of our customers are concerned by this, especially because there may be some samples that have robust germline amplification greater than the valid size range. We do not expect the germline amplification to outcompete true *D<sub>H</sub> - J<sub>H</sub>* rearrangements. PCR amplicons generated from germline templates are much larger than true *D<sub>H</sub> - J<sub>H</sub>* rearrangements. As a result, PCR products of germline amplifications are less robust when a specific target is present in samples.

9. **Why does the polyclonal control produce a peak around 148 bp when amplified with *IGK* Tube A – 6FAM?**

The 148 bp peak is a result of the restricted repertoire of *IGK* and this peak commonly appears flanked by several smaller peaks on each side. It is still possible to have a true clonal rearrangement at this size in samples. If you suspect that this peak is clonal in one of your samples, we recommend following up with heteroduplex analysis. Alternatively, NGS-based LymphoTrack® and LymphoTrack® Dx Assays provide an easier interpretation for *IGK* and reduces the number of master mixes to just one reaction.

10. **What T-cell receptor kits would you recommend to detect T-cell clonal rearrangements?**

Ideally, you should perform tests for *TRB*, *TRG*, and *TRD* to achieve the highest sensitivity. The EuroClonality/BIOMED-2 Group has shown that testing both *TRB* and *TRG* offers roughly the same sensitivity for the detection of T-cell malignancies as testing all three targets; however, they highly recommend testing all three assays in parallel to achieve optimal clinical sensitivity. *TRD* is especially useful in cases of suspected immature T-cell proliferations (see Figure 2 and Table 2 in *Leukemia* (2007) 21, 201-206). We also offer NGS kits for *TRG* for use with MiSeq® or Ion S5/PGM™ instruments and for *TRB* for use with MiSeq®.

11. **What are the differences between the *TCRG* Gene Clonality Assay and the T-Cell Receptor Gamma Gene Rearrangement Assay 2.0?**

The *TCRG* Gene Clonality Assay was designed by the EuroClonality/ BIOMED-2 Group and consists of two master mixes. For polyclonal populations, four Gaussian distributions are generated. The T-Cell Receptor Gamma Gene Rearrangement Assay 2.0 was designed by Invivoscribe and its performance was subsequently reviewed and validated by the EuroClonality/ BIOMED-2 Group. It targets all functional V<sub>H</sub> - J<sub>H</sub> rearrangements in a single master mix and produces smaller amplicons grouped under a single Gaussian distribution. This allows for easier interpretation and makes the assay more suitable for DNA extracted from FFPE tissue, which may consist of partially degraded DNA that would not amplify well with the larger valid size range of the *TCRG* Gene Clonality Assay.

12. **What are the differences between the *IGH-BCL2* Translocation Assay and the *IGH-BCL2* t(14;18) Translocation Assay?**

The *IGH-BCL2* Translocation Assay was designed by the EuroClonality/BIOMED-2 Group and is available as either a CE-IVD or research use only assay whereas; the *IGH-BCL2* t(14;18) Translocation Assay was designed by Invivoscribe and is only available for research use only. Both of these assays target MBR and Mcr translocations, but the *IGH-BCL2* Translocation Assay also targets the translocations at the 3' Mbr. The *IGH-BCL2* t(14;18) Translocation Assay was designed as a nested PCR allowing greater sensitivities (1 clonal cell per 10,000 normal cells) to be achieved. The limit of detection of the *IGH-BCL2* Translocation Assay is 1 clonal cell per 100 normal cells. Lastly, the *IGH-BCL2* Translocation Assay includes 33 reactions, whereas the *IGH-BCL2* t(14;18) Translocation Assay includes 30 reactions.

13. **Do you offer quantitative chromosome translocation (e.g., *BCR-ABL1*) controls?**

Our controls are validated for qualitative use, although our customers do successfully use them with quantitative assays. Unfortunately, we cannot guarantee their performance with any assay that was not designed by Invivoscribe.

14. **Which capillary electrophoresis instruments are currently validated for use with our assay kits?**

Currently the capillary electrophoresis instruments Invivoscribe has validated include: ABI 3100 and 3130 series for all capillary electrophoresis detection assays. The ABI 310 and 3500 instrument series have also been validated for the majority of our capillary electrophoresis detection assays. We are not able to support using instruments not listed as validated in the instructions for use of our CE-IVD assays.

15. **What are the recommended settings for my ABI instrument?**

Instruments should be calibrated with the DS-30 matrix standards (Dye set D) for the ABI 310, 3100, or 3130 instrument series. For the ABI 3500 sequencer series, we advise that you calibrate the instrument with DS-33 matrix standards. We also recommend using either POP-4 or POP-7 depending on which ABI instrument you are using. If your equipment supports POP-7, we recommend using this polymer as it can be utilized for both fragment analysis and sequencing; whereas, POP-4 can only be utilized for fragment analysis.

16. **How should peaks outside the valid size range be interpreted when using assay kits?**

You should not interpret peaks outside of the valid size range; although, in theory, it is possible to have a true rearrangement fall outside this region. If you are concerned about a suspect peak, you may sequence your product for confirmation. Please note that samples should always be interpreted within the context of all available clinical information.

17. **Is cell-free DNA (cfDNA) a suitable sample type for Invivoscribe LymphoTrack® or LymphoTrack® Dx Assays?**

The average size of cfDNA (~170 bps) makes it a suitable sample type to run with *IGH* FR3 master mixes. The use of cfDNA with *TRG* master mixes might be possible, but expected amplicon sizes generated with this assay are near the upper limits of the fragment lengths typically found with this sample type.

18. **Is DNA extracted from FFPE tissue suitable to use with Invivoscribe LymphoTrack® or LymphoTrack® Dx Assays?**

To ensure DNA from challenging specimens is of sufficient quality and quantity to generate a valid result, samples may be tested with the Specimen Control Size Ladder master mix.

19. **On which instruments can I use the LymphoTrack® and LymphoTrack® Dx Assays?**

We have different versions of our assays for the S5/PGM™ and MiSeq® instruments (LymphoTrack *TRB* is currently available only on MiSeq®). No other DNA sequencers (e.g. 454) are currently supported. Assays for the Ion S5/PGM™ and MiSeq® platforms differ slightly in terms of the total number of indices, etc., but both have similar benefits such as a one-step PCR reaction and included bioinformatics software.

20. **How much DNA is needed for the LymphoTrack® and LymphoTrack® Dx Assays?**

50 ng of high-quality genomic DNA is required for the Ion S5/PGM™ and MiSeq® LymphoTrack and LymphoTrack Dx Assays for clonality and somatic hypermutation applications.

21. **Can I use a different library quantification method or kit?**  
We recommend using the KAPA™ kit for MiSeq® assays and either the 2100 Bioanalyzer® or the LabChip® GX for the Ion S5/ PGM™ assays.
22. **Will the LymphoTrack® or LymphoTrack® Dx analysis software work on my computer?**  
The software requires Microsoft Windows 7 (64-bit) and Excel 2007, 2010, or 2013 and will work with most desktop or laptop PCs. For specific requirements please refer to the software instructions for use.
23. **Can I use the LymphoTrack® or LymphoTrack® Dx bioinformatics software with a different assay?**  
No, the software will only work with datasets obtained by our LymphoTrack and LymphoTrack Dx Assays.
24. **What characters can I use when naming my samples and the file pathways? What types of files are accepted by the LymphoTrack® and LymphoTrack® Dx Software - MiSeq®?**  
Our software only recognizes file names and pathways that contain the following characters (A-Z, a-z, 0-9, . (dot), \_ (underscore), - (hyphen)). In addition, spaces in the pathname for the data files or software (pathnames include file folders and file names) should be avoided. If the software encounters a character that is not listed above or extra spaces, an error message may be generated. Furthermore, the software is only compatible with adaptor-trimmed fastq.gz files that are generated by the MiSeq® Reporter Software when the MiSeq® instrument is used. An example of the naming format that the MiSeq® Reporter uses: SampleName\_S1\_L001\_R1\_001.fastq.gz and SampleName\_S1\_L001\_R2\_001.fastq.gz.
25. **Do the Invivoscribe MiSeq® indices correspond to the Illumina® indices?**  
The indices included in our MiSeq® master mixes follow Illumina®'s TruSeq LT nomenclature. For instance, *IGH* FR1 MiSeq® 01 corresponds to A001. Information for the other indices can be found in the instructions for use on how to set up the MiSeq® Sample Sheet to detect the appropriate indices.
26. **Why am I getting a low percent passing filter and Q30 score?**  
Low Q30 and percent passing filter (%PF) scores could be an indication that the flow cell is overloaded. If this is suspected, verify your amplicon and library calculations and quantifications are correct. Low run metrics can also be attributed to many additional factors including poor quality DNA, contamination, flow cell or instrument issues, etc. Please refer to your Illumina MiSeq® user guides and contact Illumina® Support.
27. **Why is the same V<sub>H</sub>-J<sub>H</sub> rearrangement combination and sequence shared by two groups of reads, one of which is several bases shorter than the other when looking at the Read Summary tab of the excel document created by the LymphoTrack® Visualization Tool?**  
Our software was designed to list every unique sequence separately in order for the customer to see all of the data and make their own determination on how to interpret it. The several base pair difference can be due to a number of factors including amplification errors and sequencing errors. It could also be a result of similarities between some of the primer sequences that were designed to ensure maximum coverage. We also include a Merged Read Summary report for your reference that combines sequences that only differ by 1 or 2 basepairs.
28. **Do I need to perform an adapter ligation prior to sequencing my products?**  
Performing an adapter ligation is not needed. The primers included in our LymphoTrack and LymphoTrack Dx master mixes already include the appropriate index barcodes and adapter sequences. After PCR amplification, you will be able to proceed with amplicon purification, amplicon quantification, library pooling, and sequencing.
29. **If the LymphoTrack® or LymphoTrack® Dx software generated an error, what information should I submit to Technical Support?**  
Please submit the \*.txt Log file that should have been created by the software in the output folder, a screenshot of the sample directory, and the Lot Number of the software CD you are using to [support@invivoscribe.com](mailto:support@invivoscribe.com).
30. **Are controls provided with the kits? Can you purchase additional controls? How are they supplied?**  
Each kit contains the necessary positive and negative controls required to perform the assay; additional controls may also be purchased separately. Single-tube DNA controls are provided as 100 µL aliquots of 200 µg/mL in 1/10 TE Buffer, 50 µL aliquots of 50 µg/mL in 1/10 TE Buffer, and 45 µL aliquots of 15 µg/mL in 1/10 TE Buffer. Single-tube RNA controls are provided as 100 µL aliquots of 400 µg/ml in RNase free in glass distilled water.
31. **What are the differences between dilution sets, sensitivity panels, and proficiency panels?**
- 31a. **RNA Dilution Sets**  
BCR/ABL b3a2 (Cat# 4-085-0210), BCR/ABL b2a2 (Cat# 4-085-0310), and BCR/ABL e1a2 (Cat# 4-085-0110). These sets contain six tubes: 100% negative control RNA and volume to volume (v/v) dilutions (10<sup>-1</sup>, 10<sup>-2</sup>, 10<sup>-3</sup>, 10<sup>-4</sup>, and 10<sup>-5</sup>) of the positive control RNA into the negative control RNA (IVS-0048). The RNA Dilution Sets are supplied at a concentration of 400 µg/mL, and each tube contains 50 µL. These dilution sets may be used to establish a standard reference curve, as proficiency controls, as sensitivity controls for specific target assays, and as routine testing controls for cDNA synthesis, amplification and detection.
- 31b. **RNA Sensitivity Panels**  
These panels consist of seven tubes: 100% positive control RNA and v/v dilutions (10<sup>-1</sup>, 10<sup>-2</sup>, 10<sup>-3</sup>, 10<sup>-4</sup>, 10<sup>-5</sup>, and 10<sup>-6</sup>) of the positive control RNA into the negative control RNA (IVS-0035). The RNA Sensitivity Panels are supplied at a concentration of 400 µg/mL, and each tube contains 100 µL. The RNA Sensitivity Panels may be used as sensitivity controls for specific target assays, and as routine testing controls for cDNA synthesis, amplification and detection.
- 31c. **DNA Sensitivity Panels**  
Consist of six tubes: 100% clonal DNA and v/v dilutions of the clonal DNA into negative polyclonal DNA (IVS-0000) to make 30%, 20%, 10%, 5%, and 1% dilutions. The DNA Sensitivity Panels are supplied at a concentration of 200 µg/mL and each tube contains 100 µL. The DNA Sensitivity Panels may be used as sensitivity controls for specific target assays.
- 31d. **RNA Proficiency Panel**  
The proficiency panel for BCR-ABL1 t(9;22) can be used as a sensitivity control for specific target assays, and as routine testing controls for cDNA synthesis, amplification and detection. It consists of ten tubes: 100% positive control RNA and v/v dilutions (10<sup>-2</sup> and 10<sup>-4</sup>) of IVS-0003, IVS-0011 and IVS-0032. It also includes BCR-ABL1 Negative Clonal Control RNA (IVS-0035).



# Poster Abstracts

## Evaluation of an Alternative Fragmentation Method in High Throughput NGS Sample Testing of Minimal Residual Disease in Hematological Malignancies

Poster Presented at: Association of Molecular Pathology 2019 Annual Meeting. 2019 Nov. 7-9. Baltimore, MD, USA.

## A Next-Generation-Sequencing Based Analysis of Clonality across 39 Subjects Treated for Lymphoproliferative Disorders Reveals Matching Clones in the Diverse *IGH* Locus

Poster Presented at: Association of Molecular Pathology 2019 Annual Meeting. 2019 Nov. 7-9. Baltimore, MD, USA.

## Comparing DNA Extraction Methods for the LymphoTrack IVD *TRG* Assay

Poster Presented at: Association of Molecular Pathology 2019 Annual Meeting. 2019 Nov. 7-9. Baltimore, MD, USA.

## Comparing Minimal Residual Disease Detection in Multiple Myeloma using NGS-Based LymphoTrack® Assays and Flow Cytometry

Poster Presented at: Association of Molecular Pathology Global 2019 Annual Meeting. 2019 May 16-18. Hong Kong, CN.

## LymphoTrack® Low Positive Control and LymphoQuant® Internal Control for MiSeq® and Ion S5/PGM™ LymphoTrack Assays

Poster Presented at: Association of Molecular Pathology Global 2019 Annual Meeting. 2019 May 16-18. Hong Kong, CN.

## Validation of an NGS Based Assay for Monitoring *FLT3* ITD and TKD Variants in AML Subjects

Poster Presented at: Association of Molecular Pathology Global 2019 Annual Meeting. 2019 May 16-18. Hong Kong, CN.

## Minimal Residual Disease in AML can be Monitored Utilizing Cell-Free DNA

Poster Presented at: Association of Molecular Pathology 2018 Annual Meeting. 2018 Nov. 1-3. San Antonio, TX, USA.

## Detection of Clonal Rearrangements in Multiple Myeloma Sample using LymphoTrack® Assays

Poster Presented at: Association of Molecular Pathology 2018 Annual Meeting. 2018 Nov. 1-3. San Antonio, TX, USA.

## Genetic Heterogeneity and Stratification of AML Samples with *NPM1* Mutation Detected by the MyAML® NGS Test

Poster presented at: Association for Molecular Pathology 2017 Annual Meeting. 2017 November 16-18, Salt Lake City, UT, USA.

## Clonality Detection Using Next-Generation Sequencing and Capillary Electrophoresis Methods in Suspect Lymphoproliferative Samples

Poster presented at: Association for Molecular Pathology 2017 Annual Meeting. 2017 November 16-18, Salt Lake City, UT, USA.

## Validation of the LeukoStrat® CDx *FLT3* Mutation Assay: Used to Detect both Internal Tandem Duplication (ITD) and Tyrosine Kinase Domain (TKD) Mutations and Response to Midostaurin in 1058 Patients with AML

Poster presented at: Association for Molecular Pathology 2017 Annual Meeting. 2017 November 16-18, Salt Lake City, UT, USA.

## Multiple Highly Concordant Assays Facilitate Analyses of Clinical Samples at Different Scales and Sensitivities

Poster presented at: Association for Molecular Pathology 2017 Annual Meeting. 2017 November 16-18, Salt Lake City, UT, USA.

## Detection of Clonal *TRG* and *TRB* Gene Rearrangements Using Next-Generation Sequencing

Poster presented at: Association for Molecular Pathology 2017 Annual Meeting. 2017 November 16-18, Salt Lake City, UT, USA.

## Analysis and Characterization of Hematologic Cancers Using a Comprehensive NGS Panel Comprised of DNA and RNA Baits Targeting 704 Genes

Poster presented at: 22nd Congress of the European Hematology Association. 2017 June 22-25. Madrid, Spain.

## Next Generation Sequencing Targeted Panel for Minimal Residual Disease Monitoring in Acute Myeloid Leukemia

Poster presented at: 22nd Congress of the European Hematology Association. 2017 June 22-25. Madrid, Spain.

## Detection of Clonality in Clinical Specimens from Suspected B-Cell Malignancies Using Comprehensive *IGH* Lymphotrack® MiSeq® and PGM® Assays

Poster presented at: 22nd Congress of the European Hematology Association. 2017 June 22-25. Madrid, Spain.

## Small Customizable NGS Based Target Capture Panels Detect Variants in Clinical Specimens at Frequencies as Low as 0.5%

Poster presented at: 22nd Congress of the European Hematology Association. 2017 June 22-25. Madrid, Spain.

## Detecting B-Cell Clonality in Clinical Samples using a Comprehensive NGS LymphoTrack Dx® *IGH* FR1/2/3 Assay

Poster presented at: Association for Molecular Pathology Global 2017 Meeting. 2017 April 3-5. Berlin, Germany.

## Assessment of Minimal Residual Disease in Patients with Acute Myeloid Leukemia by Monitoring *FLT3* and *NPM1* Mutations

Poster presented at: Association for Molecular Pathology Global 2017 Meeting. 2017 April 3-5. Berlin, Germany.

## A Precision Medicine Approach Incorporating Both Molecular and In Vitro Functional Data to Treat Patients with Relapsed/Refractory Acute Myeloid Leukemia

Poster Presented at: 58th Annual American Society for Hematology Meeting. 2016 Dec. 3-6. San Diego, CA, USA.

\*For copies of our recent posters, please email us at [marketing@invivoscribe.com](mailto:marketing@invivoscribe.com) or visit our website at [www.invivoscribe.com](http://www.invivoscribe.com)



---

**Precision Medicine Assays Detect Novel Targetable *FLT3* Fusions Amenable to Therapeutic Intervention in a Patient with Refractory Acute Myeloid Leukemia**

Poster Presented at: 58th Annual American Society for Hematology Meeting. 2016 Dec. 3-6. San Diego, CA, USA.

---

**Next-Generation Sequencing of *FLT3/ITD* for Minimal Residual Disease Monitoring in Leukemia Patients**

Poster Presented at: Association for Molecular Pathology 2016 Annual Meeting. November 10-12, 2016 at the Charlotte Convention Center in Charlotte, NC, USA.

---

**Next-Generation Sequencing of *NPM1* for Minimal Residual Disease Monitoring in Leukemia Patients**

Poster Presented at: Association for Molecular Pathology 2016 Annual Meeting. November 10-12, 2016 at the Charlotte Convention Center in Charlotte, NC, USA.

---

**Detection of Clonal Immunoglobulin and T-Cell Receptor Gene Rearrangements in Acute Myeloid Leukemia**

Poster Presented at: Association for Molecular Pathology 2016 Annual Meeting. November 10-12, 2016 at the Charlotte Convention Center in Charlotte, NC, USA.

---

**Development of a Comprehensive *IGH* NGS Assay for Detecting Suspected B-Cell Clonality**

Poster Presented at: Association for Molecular Pathology 2016 Annual Meeting. November 10-12, 2016 at the Charlotte Convention Center in Charlotte, NC, USA.

---

**Detection of Minimal Residual Disease in *FLT3/ITD* AML**

Poster presented at: American Society of Clinical Oncology 2016 Annual Meeting. June 3-7, 2016 at McCormick Place in Chicago, Illinois, USA.

---

**Development of LymphoTrack® Bioinformatics Methods: Clonality Testing, Somatic Hypermutation, and Minimal Residual Disease**

Poster Presented at: Association for Molecular Pathology 2015 Annual Meeting. 2015 Nov 4-8. Austin, TX, USA.

---

**Detection of Clonal *TRG* Gene Rearrangements Shows Improved Sensitivity and Positive Predictive Value Compared to Fragment Analysis Using BIOMED-2 Primers and Capillary Electrophoresis**

Poster Presented at: Association for Molecular Pathology 2015 Annual Meeting. 2015 Nov 4-8. Austin, TX, USA.

---

**Development of an NGS Assay for *IGK* that can be Combined with *IGH* for Identifying Clonal Populations in Lymphoid Malignancies**

Poster Presented at: 20th Congress of the European Hematology Association. 2015 June 11-14. Vienna, Austria.

---

**Clinical Assessment of Chronic Lymphocytic Leukemia (CLL) samples for Somatic Hypermutation Status by Next-Generation Sequencing and Sanger Sequencing**

Poster Presented at: 20th Congress of the European Hematology Association. 2015 June 11-14. Vienna, Austria.

---

---

**Somatic Hypermutation and V-J Gene Usage for CLL Prognosis: Evaluating Data from MiSeq® NGS vs. PCR-Sanger Sequencing Approaches**

Poster Presented at: 56th Annual American Society for Hematology Meeting. 2014 Dec. 6-9. San Francisco, CA, USA.

---

**International Validation of a Harmonized NGS PGM™ Assay at Clinical Labs in the US and the EU**

Poster Presented at: Association for Molecular Pathology 2014 Annual Meeting. 2014 Nov 13-15. National Harbor, MD, USA.

---

**Performance of an *IGH* Somatic Hypermutation Assay with Associated LymphoTrack® Bioinformatics Developed for the MiSeq® NGS Platform**

Poster Presented at: 19th Congress of the European Hematology Association. 2014 June 12-15. Milan, Italy.

---

**Concordance in *IGH* & *TRG* Clonality Testing: Comparison of Data Generated Using the MiSeq® & PGM™ Platforms**

Poster Presented at: 19th Congress of the European Hematology Association. 2014 June 12-15. Milan, Italy.

---

**Combined *TRG* and *IGH* Clonality Testing on the PGM™ Using LymphoTrack® Reagents & Bioinformatics**

Poster Presented at: 19th Congress of the European Hematology Association. 2014 June 12-15. Milan, Italy.

---

**Identifying and Monitoring *IGH* Clonality Using Massively Parallel Sequencing and Associated Bioinformatics**

Poster Presented at: Association for Molecular Pathology 2013 Annual Meeting. 2013 Nov. 15-16. Phoenix, AZ, USA.

---

**Detecting Minimal Residual Disease Using a Massively Parallel Sequencing *TCRG* Assay**

Poster Presented at: Association for Molecular Pathology 2013 Annual Meeting. 2013 Nov. 15-16. Phoenix, AZ, USA.

---

**Identifying and Monitoring *TCRG* Clonality Using Massively Parallel Sequencing and Associated Bioinformatics**

Poster Presented at: 18th Congress of the European Hematology Association. 2013 June 13-16. Stockholm, Sweden.

---

# Product List by Catalog Number

## Research Use Only Assays Capillary & Gel Fragment Analysis

1-100-0010	<i>IGH</i> + <i>IGK</i> B-Cell Clonality Assay – Gel Detection
1-100-0020	<i>IGH</i> + <i>IGK</i> B-Cell Clonality Assay MegaKit – Gel Detection
1-100-0031	<i>IGH</i> + <i>IGK</i> B-Cell Clonality Assay – ABI Fluorescence Detection
1-100-0041	<i>IGH</i> + <i>IGK</i> B-Cell Clonality Assay MegaKit – ABI Fluorescence Detection
1-101-0010	<i>IGH</i> Gene Rearrangement Assay – Gel Detection
1-101-0020	<i>IGH</i> Gene Clonality Assay – Gel Detection
1-101-0030	<i>IGH</i> Gene Rearrangement Assay MegaKit – Gel Detection
1-101-0040	<i>IGH</i> Gene Clonality Assay MegaKit – Gel Detection
1-101-0051	<i>IGH</i> Gene Rearrangement Assay – ABI Fluorescence Detection
1-101-0061	<i>IGH</i> Gene Clonality Assay – ABI Fluorescence Detection
1-101-0071	<i>IGH</i> Gene Rearrangement Assay MegaKit – ABI Fluorescence Detection
1-101-0081	<i>IGH</i> Gene Clonality Assay MegaKit – ABI Fluorescence Detection
1-102-0020	<i>IGK</i> Gene Clonality Assay – Gel Detection
1-102-0021	<i>IGK</i> Gene Clonality Assay – ABI Fluorescence Detection
1-102-0030	<i>IGK</i> Gene Clonality Assay MegaKit – Gel Detection
1-102-0031	<i>IGK</i> Gene Clonality Assay MegaKit – ABI Fluorescence Detection
1-103-0010	<i>IGL</i> Gene Clonality Assay – Gel Detection
1-103-0011	<i>IGL</i> Gene Clonality Assay – ABI Fluorescence Detection
1-103-0020	<i>IGL</i> Gene Clonality Assay MegaKit – Gel Detection
1-103-0021	<i>IGL</i> Gene Clonality Assay MegaKit – ABI Fluorescence Detection
1-200-0010	<i>TCRB</i> + <i>TCRG</i> T-Cell Clonality Assay – Gel Detection
1-200-0011	<i>TCRB</i> + <i>TCRG</i> T-Cell Clonality Assay – ABI Fluorescence Detection
1-200-0020	<i>TCRB</i> + <i>TCRG</i> T-Cell Clonality Assay MegaKit – Gel Detection
1-200-0021	<i>TCRB</i> + <i>TCRG</i> T-Cell Clonality Assay MegaKit – ABI Fluorescence Detection
1-205-0010	<i>TCRB</i> Gene Clonality Assay – Gel Detection
1-205-0011	<i>TCRB</i> Gene Clonality Assay – ABI Fluorescence Detection
1-205-0020	<i>TCRB</i> Gene Clonality Assay MegaKit – Gel Detection
1-205-0021	<i>TCRB</i> Gene Clonality Assay MegaKit – ABI Fluorescence Detection
1-206-0010	<i>TCRD</i> Gene Clonality Assay – Gel Detection
1-206-0011	<i>TCRD</i> Gene Clonality Assay – ABI Fluorescence Detection
1-206-0020	<i>TCRD</i> Gene Clonality Assay MegaKit – Gel Detection
1-206-0021	<i>TCRD</i> Gene Clonality Assay MegaKit – ABI Fluorescence Detection
1-207-0010	T-Cell Receptor Gamma Gene Rearrangement Assay – Gel Detection
1-207-0020	<i>TCRG</i> Gene Clonality Assay – Gel Detection
1-207-0021	<i>TCRG</i> Gene Clonality Assay – ABI Fluorescence Detection
1-207-0030	T-Cell Receptor Gamma Gene Rearrangement Assay MegaKit – Gel Detection
1-207-0040	<i>TCRG</i> Gene Clonality Assay MegaKit – Gel Detection
1-207-0041	<i>TCRG</i> Gene Clonality Assay MegaKit – ABI Fluorescence Detection
1-207-0051	T-Cell Receptor Gamma Gene Rearrangement Assay – ABI Fluorescence Detection
1-207-0071	T-Cell Receptor Gamma Gene Rearrangement Assay MegaKit – ABI Fluorescence Detection
1-207-0101	T-Cell Receptor Gamma Gene Rearrangement Assay 2.0 – ABI Fluorescence Detection
1-207-0111	T-Cell Receptor Gamma Gene Rearrangement Assay 2.0 MegaKit – ABI Fluorescence Detection
1-308-0010	<i>BCL1/IGH</i> Translocation Assay – Gel Detection
1-308-0020	<i>BCL1/IGH</i> Translocation Assay MegaKit – Gel Detection
1-309-0010	<i>BCL2/JH</i> t(14;18) Translocation Assay – Gel Detection
1-309-0020	<i>BCL2/JH</i> Translocation Assay – Gel Detection
1-309-0030	<i>BCL2/JH</i> t(14;18) Translocation Assay MegaKit – Gel Detection
1-309-0040	<i>BCL2/JH</i> Translocation Assay MegaKit – Gel Detection
1-310-0010	<i>BCR/ABL</i> t(9;22) Translocation Assay – Gel Detection
1-310-0020	<i>BCR/ABL</i> t(9;22) Translocation Assay MegaKit – Gel Detection
1-310-0031	<i>BCR/ABL</i> t(9;22) Translocation Assay – ABI Fluorescence Detection
1-310-0041	<i>BCR/ABL</i> t(9;22) Translocation Assay MegaKit – ABI Fluorescence Detection
1-311-0010	<i>PML/RARα</i> t(15;17) Translocation Assay – Gel Detection
1-311-0011	<i>PML/RARα</i> t(15;17) Translocation Assay – ABI Fluorescence Detection
1-311-0020	<i>PML/RARα</i> t(15;17) Translocation Assay MegaKit – Gel Detection
1-311-0021	<i>PML/RARα</i> t(15;17) Translocation Assay MegaKit – ABI Fluorescence Detection
1-412-0010	<i>FLT3</i> Mutation Assay – Gel Detection
1-412-0020	<i>FLT3</i> Mutation Assay MegaKit – Gel Detection
1-412-0031	<i>FLT3</i> Mutation Assay – ABI Fluorescence Detection
1-412-0041	<i>FLT3</i> Mutation Assay MegaKit – ABI Fluorescence Detection

2-096-0020	Specimen Control Size Ladder – Unlabeled
2-096-0021	Specimen Control Size Ladder – 6FAM
2-101-0010	<i>IGH</i> Tube A – Unlabeled
2-101-0011	<i>IGH</i> Tube A – 6FAM
2-101-0020	<i>IGH</i> Tube B – Unlabeled
2-101-0030	<i>IGH</i> Tube C – Unlabeled
2-101-0031	<i>IGH</i> Tube C – HEX
2-101-0040	<i>IGH</i> Tube D – Unlabeled
2-101-0041	<i>IGH</i> Tube D – HEX
2-101-0050	<i>IGH</i> Tube E – Unlabeled
2-101-0051	<i>IGH</i> Tube E – 6FAM
2-101-0060	<i>IGH</i> Framework 1 (FR1) – Unlabeled
2-101-0061	<i>IGH</i> Framework 1 (FR1) – 6FAM
2-101-0070	<i>IGH</i> Framework 2 (FR2) – Unlabeled
2-101-0080	<i>IGH</i> Framework 3 (FR3) – Unlabeled
2-101-0081	<i>IGH</i> Framework 3 (FR3) – HEX
2-101-0091	<i>IGH</i> Framework 2 (FR2) – 6FAM
2-101-0101	<i>IGH</i> Tube B – 6FAM
2-101-0170	Hypermutation Mix 1 v2.0 – Unlabeled
2-101-0171	Hypermutation Mix 1 v2.0 – 6FAM
2-101-0180	Hypermutation Mix 2 v2.0 – Unlabeled
2-101-0181	Hypermutation Mix 2 v2.0 – 6FAM
2-102-0010	<i>IGK</i> Tube A – Unlabeled
2-102-0011	<i>IGK</i> Tube A – 6FAM
2-102-0020	<i>IGK</i> Tube B – Unlabeled
2-102-0021	<i>IGK</i> Tube B – 6FAM
2-103-0010	<i>IGL</i> Tube – Unlabeled
2-103-0011	<i>IGL</i> Tube – 6FAM
2-205-0010	<i>TCRB</i> Tube A – Unlabeled
2-205-0011	<i>TCRB</i> Tube A – 6FAM & HEX
2-205-0020	<i>TCRB</i> Tube B – Unlabeled
2-205-0021	<i>TCRB</i> Tube B – 6FAM
2-205-0030	<i>TCRB</i> Tube C – Unlabeled
2-205-0031	<i>TCRB</i> Tube C – 6FAM & HEX
2-206-0010	<i>TCRD</i> Tube – Unlabeled
2-206-0011	<i>TCRD</i> Tube – 6FAM & HEX
2-207-0010	T-Cell Receptor Gamma Mix 1 – Unlabeled
2-207-0020	T-Cell Receptor Gamma Mix 2 – Unlabeled
2-207-0021	T-Cell Receptor Gamma Mix 2 – HEX
2-207-0030	<i>TCRG</i> Tube A – Unlabeled
2-207-0031	<i>TCRG</i> Tube A – 6FAM & HEX
2-207-0040	<i>TCRG</i> Tube B – Unlabeled
2-207-0041	<i>TCRG</i> Tube B – 6FAM & HEX
2-207-0071	T-Cell Receptor Gamma Mix 1 – 6FAM
2-207-0091	<i>TCRG</i> – 6FAM
2-308-0010	<i>BCL1/IGH</i> Tube – Unlabeled
2-309-0010	<i>BCL2/JH</i> t(14;18) (Mbr) Mix 1b – Unlabeled
2-309-0020	<i>BCL2/JH</i> t(14;18) (mcr) Mix 2b – Unlabeled
2-309-0030	<i>BCL2/JH</i> t(14;18) (Mbr) Mix 1a – Unlabeled
2-309-0040	<i>BCL2/JH</i> t(14;18) (mcr) Mix 2a – Unlabeled
2-309-0050	<i>BCL2/JH</i> Tube A – Unlabeled
2-309-0060	<i>BCL2/JH</i> Tube B – Unlabeled
2-309-0070	<i>BCL2/JH</i> Tube C – Unlabeled
2-310-0010	<i>BCR/ABL</i> t(9;22) Mix 1a – Unlabeled
2-310-0020	<i>BCR/ABL</i> t(9;22) Mix 2a – Unlabeled
2-310-0030	<i>BCR/ABL</i> t(9;22) Mix 3a – Unlabeled
2-310-0040	<i>BCR/ABL</i> t(9;22) Mix 1b – Unlabeled
2-310-0041	<i>BCR/ABL</i> t(9;22) Mix 1b – HEX
2-310-0050	<i>BCR/ABL</i> t(9;22) Mix 2b – Unlabeled
2-310-0051	<i>BCR/ABL</i> t(9;22) Mix 2b – HEX
2-310-0060	<i>BCR/ABL</i> t(9;22) Mix 2c – Unlabeled
2-310-0061	<i>BCR/ABL</i> t(9;22) Mix 2c – HEX
2-310-0070	<i>BCR/ABL</i> t(9;22) Mix 3b – Unlabeled
2-310-0071	<i>BCR/ABL</i> t(9;22) Mix 3b – 6FAM
2-310-0080	<i>BCR/ABL</i> t(9;22) Mix 3c – Unlabeled
2-310-0081	<i>BCR/ABL</i> t(9;22) Mix 3c – 6FAM
2-310-0090	<i>BCR/ABL</i> t(9;22) Mix 3d – Unlabeled
2-310-0101	<i>BCR/ABL</i> t(9;22) Mix 3d – 6FAM
2-311-0011	<i>PML/RARα</i> t(15;17) Mix 1 – HEX
2-311-0031	<i>PML/RARα</i> t(15;17) Mix 2b – HEX
2-311-0041	<i>PML/RARα</i> t(15;17) Mix 2c – HEX

## Master Mixes

2-096-0010	Amplification Control Master Mix – Unlabeled
2-096-0011	Amplification Control Master Mix – 6FAM

## BCR/ABL RNA Dilution Sets

4-085-0110	BCR/ABL e1a2 RNA Dilution Set
4-085-0210	BCR/ABL b3a2 RNA Dilution Set
4-085-0310	BCR/ABL b2a2 RNA Dilution Set

## DNA Sensitivity Panels

4-086-0040	Sensitivity Panel – IVS-0004 Clonal Control DNA
4-086-0070	Sensitivity Panel – IVS-0007 Clonal Control DNA
4-086-0090	Sensitivity Panel – IVS-0009 Clonal Control DNA
4-086-0100	Sensitivity Panel – IVS-0010 Clonal Control DNA
4-086-0190	Sensitivity Panel – IVS-0019 Clonal Control DNA
4-086-0210	Sensitivity Panel – IVS-0021 Clonal Control DNA
4-086-0300	Sensitivity Panel – IVS-0030 Clonal Control DNA

## RNA Sensitivity Panels

4-087-0030	Sensitivity Panel – IVS-0003 Clonal Control RNA
4-087-0110	Sensitivity Panel – IVS-0011 Clonal Control RNA
4-087-0150	Sensitivity Panel – IVS-0015 Clonal Control RNA
4-087-0200	Sensitivity Panel – IVS-0020 Clonal Control RNA
4-087-0320	Sensitivity Panel – IVS-0032 Clonal Control RNA

## Cell Line DNA Controls

R-088-0230	FLT3 ITD Positive Control DNA – GPR
R-088-0240	FLT3 TKD Positive Control DNA – GPR
R-088-0250	FLT3 Extraction Control – GPR
4-088-0008	IGH SHM Positive Control DNA
4-088-0010	IVS-0001 Clonal Control DNA
4-088-0098	LymphoTrack® B-cell Low Positive Control
4-088-0108	LymphoTrack® T-cell Low Positive Control
4-088-0118	LymphoQuant® B-cell Internal Control
4-088-0128	LymphoQuant® T-cell Internal Control
4-088-0190	IVS-0004 Clonal Control DNA
4-088-0210	20% IVS-0004 Clonal Control DNA
4-088-0220	10% IVS-0004 Clonal Control DNA
4-088-0230	5% IVS-0004 Clonal Control DNA
4-088-0370	IVS-0007 Clonal Control DNA
4-088-0390	20% IVS-0007 Clonal Control DNA
4-088-0400	10% IVS-0007 Clonal Control DNA
4-088-0410	5% IVS-0007 Clonal Control DNA
4-088-0420	1% IVS-0007 Clonal Control DNA
4-088-0430	IVS-0008 Clonal Control DNA
4-088-0470	5% IVS-0008 Clonal Control DNA
4-088-0480	1% IVS-0008 Clonal Control DNA
4-088-0490	IVS-0009 Clonal Control DNA
4-088-0500	30% IVS-0009 Clonal Control DNA
4-088-0510	20% IVS-0009 Clonal Control DNA
4-088-0520	10% IVS-0009 Clonal Control DNA
4-088-0530	5% IVS-0009 Clonal Control DNA
4-088-0540	1% IVS-0009 Clonal Control DNA
4-088-0550	IVS-0010 Clonal Control DNA
4-088-0560	30% IVS-0010 Clonal Control DNA
4-088-0580	10% IVS-0010 Clonal Control DNA
4-088-0590	5% IVS-0010 Clonal Control DNA
4-088-0730	IVS-0013 Clonal Control DNA
4-088-1090	IVS-0019 Clonal Control DNA
4-088-1100	30% IVS-0019 Clonal Control DNA
4-088-1110	20% IVS-0019 Clonal Control DNA
4-088-1120	10% IVS-0019 Clonal Control DNA
4-088-1130	5% IVS-0019 Clonal Control DNA
4-088-1140	1% IVS-0019 Clonal Control DNA
4-088-1210	IVS-0021 Clonal Control DNA
4-088-1220	30% IVS-0021 Clonal Control DNA
4-088-1230	20% IVS-0021 Clonal Control DNA
4-088-1240	10% IVS-0021 Clonal Control DNA
4-088-1250	5% IVS-0021 Clonal Control DNA
4-088-1260	1% IVS-0021 Clonal Control DNA
4-088-1390	IVS-0024 Clonal Control DNA
4-088-1430	5% IVS-0024 Clonal Control DNA
4-088-1690	IVS-0029 Clonal Control DNA
4-088-1700	30% IVS-0029 Clonal Control DNA
4-088-1730	5% IVS-0029 Clonal Control DNA
4-088-1750	IVS-0030 Clonal Control DNA
4-088-1760	30% IVS-0030 Clonal Control DNA
4-088-1770	20% IVS-0030 Clonal Control DNA
4-088-1780	10% IVS-0030 Clonal Control DNA
4-088-1790	5% IVS-0030 Clonal Control DNA
4-088-1800	1% IVS-0030 Clonal Control DNA
4-088-1810	IVS-0031 Clonal Control DNA
4-088-1840	10% IVS-0031 Clonal Control DNA
4-088-1860	1% IVS-0031 Clonal Control DNA

## Cell Line RNA Controls

4-089-0100	IVS-0002 Clonal Control RNA
4-089-0190	IVS-0003 Clonal Control RNA
4-089-0200	10 <sup>-1</sup> IVS-0003 Clonal Control RNA
4-089-0210	10 <sup>-2</sup> IVS-0003 Clonal Control RNA
4-089-0220	10 <sup>-3</sup> IVS-0003 Clonal Control RNA
4-089-0230	10 <sup>-4</sup> IVS-0003 Clonal Control RNA
4-089-0240	10 <sup>-5</sup> IVS-0003 Clonal Control RNA
4-089-0250	10 <sup>-6</sup> IVS-0003 Clonal Control RNA
4-089-0910	IVS-0011 Clonal Control RNA
4-089-0920	10 <sup>-1</sup> IVS-0011 Clonal Control RNA
4-089-0930	10 <sup>-2</sup> IVS-0011 Clonal Control RNA
4-089-0940	10 <sup>-3</sup> IVS-0011 Clonal Control RNA
4-089-0950	10 <sup>-4</sup> IVS-0011 Clonal Control RNA
4-089-0960	10 <sup>-5</sup> IVS-0011 Clonal Control RNA
4-089-1270	IVS-0015 Clonal Control RNA
4-089-1720	IVS-0020 Clonal Control RNA
4-089-1730	10 <sup>-1</sup> IVS-0020 Clonal Control RNA
4-089-1740	10 <sup>-2</sup> IVS-0020 Clonal Control RNA
4-089-1750	10 <sup>-3</sup> IVS-0020 Clonal Control RNA
4-089-1760	10 <sup>-4</sup> IVS-0020 Clonal Control RNA
4-089-2800	IVS-0032 Clonal Control RNA
4-089-2810	10 <sup>-1</sup> IVS-0032 Clonal Control RNA
4-089-2820	10 <sup>-2</sup> IVS-0032 Clonal Control RNA
4-089-2830	10 <sup>-3</sup> IVS-0032 Clonal Control RNA
4-089-2840	10 <sup>-4</sup> IVS-0032 Clonal Control RNA
4-089-2850	10 <sup>-5</sup> IVS-0032 Clonal Control RNA
4-089-2860	10 <sup>-6</sup> IVS-0032 Clonal Control RNA
4-089-3070	IVS-0035 Clonal Control RNA

## Plasmid DNA Control

4-090-0070	IVS-P002 Clonal Control DNA
------------	-----------------------------

## Tissue DNA Control

4-092-0010	IVS-0000 Polyclonal Control DNA
------------	---------------------------------

## RNA Proficiency Panel

4-310-0100	Proficiency Panel for BCR/ABL t(9;22) Translocations
------------	--

## Somatic Hypermutation Sanger Sequencing Assays

5-101-0030	IGH Somatic Hypermutation Assay v2.0 – Gel Detection
5-101-0031	IGH Somatic Hypermutation Assay v2.0 – ABI Fluorescence Detection
5-101-0040	IGH Somatic Hypermutation Assay v2.0 MegaKit – Gel Detection
5-101-0041	IGH Somatic Hypermutation Assay v2.0 MegaKit – ABI Fluorescence

## ABI Reagents

6-098-0051	HI-Deionized Formamide with ROX Size Standard (ABI 310)
6-098-0061	HI-Deionized Formamide with ROX Size Standard (ABI 3100)

## Next-Generation Sequencing CE-IVD LymphoTrack® Dx Assays

9-121-0059	LymphoTrack® Dx IGHV Leader Somatic Hypermutation Assay Kit A – MiSeq®
9-121-0069	LymphoTrack® Dx IGHV Leader Somatic Hypermutation Assay Panel – MiSeq®
9-121-0129	LymphoTrack® Dx IGH FR1/2/3 Assay Kit A – MiSeq®
9-121-0139	LymphoTrack® Dx IGH FR1/2/3 Assay Panel – MiSeq®
9-121-0009	LymphoTrack® Dx IGH FR1 Assay Kit A – MiSeq®
9-121-0039	LymphoTrack® Dx IGH FR1 Assay Panel – MiSeq®
9-121-0089	LymphoTrack® Dx IGH FR2 Assay Kit A – MiSeq®
9-121-0099	LymphoTrack® Dx IGH FR2 Assay Panel – MiSeq®
9-121-0109	LymphoTrack® Dx IGH FR3 Assay Kit A – MiSeq®
9-121-0119	LymphoTrack® Dx IGH FR3 Assay Panel – MiSeq®
9-121-0057	LymphoTrack® Dx IGH FR1/2/3 Assay – PGM™
9-121-0007	LymphoTrack® Dx IGH FR1 Assay – PGM™
9-121-0037	LymphoTrack® Dx IGH FR2 Assay – PGM™
9-121-0047	LymphoTrack® Dx IGH FR3 Assay – PGM™
9-122-0009	LymphoTrack® Dx IGK Assay Kit A – MiSeq®
9-122-0019	LymphoTrack® Dx IGK Assay Panel – MiSeq®
9-122-0007	LymphoTrack® Dx IGK Assay – SS/PGM™
9-225-0009	LymphoTrack® Dx TRB Assay Kit A – MiSeq®
9-225-0019	LymphoTrack® Dx TRB Assay Panel – MiSeq®
9-227-0019	LymphoTrack® Dx TRG Assay Kit A – MiSeq®
9-227-0009	LymphoTrack® Dx TRG Assay Panel – MiSeq®

## BCR/ABL RNA Dilution Sets

4-085-0110	BCR/ABL e1a2 RNA Dilution Set
4-085-0210	BCR/ABL b3a2 RNA Dilution Set
4-085-0310	BCR/ABL b2a2 RNA Dilution Set

## DNA Sensitivity Panels

4-086-0040	Sensitivity Panel – IVS-0004 Clonal Control DNA
4-086-0070	Sensitivity Panel – IVS-0007 Clonal Control DNA
4-086-0090	Sensitivity Panel – IVS-0009 Clonal Control DNA
4-086-0100	Sensitivity Panel – IVS-0010 Clonal Control DNA
4-086-0190	Sensitivity Panel – IVS-0019 Clonal Control DNA
4-086-0210	Sensitivity Panel – IVS-0021 Clonal Control DNA
4-086-0300	Sensitivity Panel – IVS-0030 Clonal Control DNA

## RNA Sensitivity Panels

4-087-0030	Sensitivity Panel – IVS-0003 Clonal Control RNA
4-087-0110	Sensitivity Panel – IVS-0011 Clonal Control RNA
4-087-0150	Sensitivity Panel – IVS-0015 Clonal Control RNA
4-087-0200	Sensitivity Panel – IVS-0020 Clonal Control RNA
4-087-0320	Sensitivity Panel – IVS-0032 Clonal Control RNA

## Cell Line DNA Controls

R-088-0230	FLT3 ITD Positive Control DNA – GPR
R-088-0240	FLT3 TKD Positive Control DNA – GPR
R-088-0250	FLT3 Extraction Control – GPR
4-088-0008	IGH SHM Positive Control DNA
4-088-0010	IVS-0001 Clonal Control DNA
4-088-0098	LymphoTrack® B-cell Low Positive Control
4-088-0108	LymphoTrack® T-cell Low Positive Control
4-088-0118	LymphoQuant® B-cell Internal Control
4-088-0128	LymphoQuant® T-cell Internal Control
4-088-0190	IVS-0004 Clonal Control DNA
4-088-0210	20% IVS-0004 Clonal Control DNA
4-088-0220	10% IVS-0004 Clonal Control DNA
4-088-0230	5% IVS-0004 Clonal Control DNA
4-088-0370	IVS-0007 Clonal Control DNA
4-088-0390	20% IVS-0007 Clonal Control DNA
4-088-0400	10% IVS-0007 Clonal Control DNA
4-088-0410	5% IVS-0007 Clonal Control DNA
4-088-0420	1% IVS-0007 Clonal Control DNA
4-088-0430	IVS-0008 Clonal Control DNA
4-088-0470	5% IVS-0008 Clonal Control DNA
4-088-0480	1% IVS-0008 Clonal Control DNA
4-088-0490	IVS-0009 Clonal Control DNA
4-088-0500	30% IVS-0009 Clonal Control DNA
4-088-0510	20% IVS-0009 Clonal Control DNA
4-088-0520	10% IVS-0009 Clonal Control DNA
4-088-0530	5% IVS-0009 Clonal Control DNA
4-088-0540	1% IVS-0009 Clonal Control DNA
4-088-0550	IVS-0010 Clonal Control DNA
4-088-0560	30% IVS-0010 Clonal Control DNA
4-088-0580	10% IVS-0010 Clonal Control DNA
4-088-0590	5% IVS-0010 Clonal Control DNA
4-088-0730	IVS-0013 Clonal Control DNA
4-088-1090	IVS-0019 Clonal Control DNA
4-088-1100	30% IVS-0019 Clonal Control DNA
4-088-1110	20% IVS-0019 Clonal Control DNA
4-088-1120	10% IVS-0019 Clonal Control DNA
4-088-1130	5% IVS-0019 Clonal Control DNA
4-088-1140	1% IVS-0019 Clonal Control DNA
4-088-1210	IVS-0021 Clonal Control DNA
4-088-1220	30% IVS-0021 Clonal Control DNA
4-088-1230	20% IVS-0021 Clonal Control DNA
4-088-1240	10% IVS-0021 Clonal Control DNA
4-088-1250	5% IVS-0021 Clonal Control DNA
4-088-1260	1% IVS-0021 Clonal Control DNA
4-088-1390	IVS-0024 Clonal Control DNA
4-088-1430	5% IVS-0024 Clonal Control DNA
4-088-1690	IVS-0029 Clonal Control DNA
4-088-1700	30% IVS-0029 Clonal Control DNA
4-088-1730	5% IVS-0029 Clonal Control DNA
4-088-1750	IVS-0030 Clonal Control DNA
4-088-1760	30% IVS-0030 Clonal Control DNA

4-088-1770	20% IVS-0030 Clonal Control DNA
4-088-1780	10% IVS-0030 Clonal Control DNA
4-088-1790	5% IVS-0030 Clonal Control DNA
4-088-1800	1% IVS-0030 Clonal Control DNA
4-088-1810	IVS-0031 Clonal Control DNA
4-088-1840	10% IVS-0031 Clonal Control DNA
4-088-1860	1% IVS-0031 Clonal Control DNA

## Cell Line RNA Controls

4-089-0100	IVS-0002 Clonal Control RNA
4-089-0190	IVS-0003 Clonal Control RNA
4-089-0200	10 <sup>-1</sup> IVS-0003 Clonal Control RNA
4-089-0210	10 <sup>-2</sup> IVS-0003 Clonal Control RNA
4-089-0220	10 <sup>-3</sup> IVS-0003 Clonal Control RNA
4-089-0230	10 <sup>-4</sup> IVS-0003 Clonal Control RNA
4-089-0240	10 <sup>-5</sup> IVS-0003 Clonal Control RNA
4-089-0250	10 <sup>-6</sup> IVS-0003 Clonal Control RNA
4-089-0910	IVS-0011 Clonal Control RNA
4-089-0920	10 <sup>-1</sup> IVS-0011 Clonal Control RNA
4-089-0930	10 <sup>-2</sup> IVS-0011 Clonal Control RNA
4-089-0940	10 <sup>-3</sup> IVS-0011 Clonal Control RNA
4-089-0950	10 <sup>-4</sup> IVS-0011 Clonal Control RNA
4-089-0960	10 <sup>-5</sup> IVS-0011 Clonal Control RNA
4-089-1270	IVS-0015 Clonal Control RNA
4-089-1720	IVS-0020 Clonal Control RNA
4-089-1730	10 <sup>-1</sup> IVS-0020 Clonal Control RNA
4-089-1740	10 <sup>-2</sup> IVS-0020 Clonal Control RNA
4-089-1750	10 <sup>-3</sup> IVS-0020 Clonal Control RNA
4-089-1760	10 <sup>-4</sup> IVS-0020 Clonal Control RNA
4-089-2800	IVS-0032 Clonal Control RNA
4-089-2810	10 <sup>-1</sup> IVS-0032 Clonal Control RNA
4-089-2820	10 <sup>-2</sup> IVS-0032 Clonal Control RNA
4-089-2830	10 <sup>-3</sup> IVS-0032 Clonal Control RNA
4-089-2840	10 <sup>-4</sup> IVS-0032 Clonal Control RNA
4-089-2850	10 <sup>-5</sup> IVS-0032 Clonal Control RNA
4-089-2860	10 <sup>-6</sup> IVS-0032 Clonal Control RNA
4-089-3070	IVS-0035 Clonal Control RNA

## Plasmid DNA Control

4-090-0070	IVS-P002 Clonal Control DNA
------------	-----------------------------

## Tissue DNA Control

4-092-0010	IVS-0000 Polyclonal Control DNA
------------	---------------------------------

## RNA Proficiency Panel

4-310-0100	Proficiency Panel for BCR/ABL t(9;22) Translocations
------------	--

## Somatic Hypermutation Sanger Sequencing Assays

5-101-0030	IGH Somatic Hypermutation Assay v2.0 – Gel Detection
5-101-0031	IGH Somatic Hypermutation Assay v2.0 – ABI Fluorescence Detection
5-101-0040	IGH Somatic Hypermutation Assay v2.0 MegaKit – Gel Detection
5-101-0041	IGH Somatic Hypermutation Assay v2.0 MegaKit – ABI Fluorescence

## ABI Reagents

6-098-0051	HI-Deionized Formamide with ROX Size Standard (ABI 310)
6-098-0061	HI-Deionized Formamide with ROX Size Standard (ABI 3100)

## Next-Generation Sequencing CE-IVD LymphoTrack® Dx Assays

9-121-0059	LymphoTrack® Dx IGHV Leader Somatic Hypermutation Assay Kit A – MiSeq®
9-121-0069	LymphoTrack® Dx IGHV Leader Somatic Hypermutation Assay Panel – MiSeq®
9-121-0129	LymphoTrack® Dx IGH FR1/2/3 Assay Kit A – MiSeq®
9-121-0139	LymphoTrack® Dx IGH FR1/2/3 Assay Panel – MiSeq®
9-121-0009	LymphoTrack® Dx IGH FR1 Assay Kit A – MiSeq®
9-121-0039	LymphoTrack® Dx IGH FR1 Assay Panel – MiSeq®

# Alphabetical Index

## A

ABI Fluorescence Detection Reagents	
HI-Deionized Formamide with ROX Size Standard (ABI 310)	147
HI-Deionized Formamide with ROX Size Standard (ABI 3100)	147
Amplification Control Master Mix	
Amplification Control Master Mix – 6FAM	146
Amplification Control Master Mix – Unlabeled	146
Analyte Specific Reagents	
<i>BCL2</i> / <i>JH</i> 3'Mbr - Unlabeled	131
<i>BCL2</i> / <i>JH</i> Mbr - Unlabeled	131
<i>BCL2</i> / <i>JH</i> mcr - Unlabeled	131
<i>BCR/ABL</i> b2.1- $\alpha$ 3.1 - Unlabeled	131
<i>BCR/ABL</i> b2.2- $\alpha$ 2.2 - 6FAM	131
<i>BCR/ABL</i> b2.2- $\alpha$ 3.2 - 6FAM	131
<i>BCR/ABL</i> e1.1- $\alpha$ 3.1 - Unlabeled	131
<i>BCR/ABL</i> e1.2- $\alpha$ 2.2 - HEX	131
<i>BCR/ABL</i> e1.2- $\alpha$ 3.2 - HEX	131
<i>BCR/ABL</i> b3.2- $\alpha$ 3.2 - 6FAM	131
<i>IGH</i> DH1 - 6 - HEX	131
<i>IGH</i> DH7 - 6FAM	131
<i>IGH</i> FR1 - 6FAM	131
<i>IGH</i> FR1 - Unlabeled	131
<i>IGH</i> FR2 - 6FAM	131
<i>IGH</i> FR2 - Unlabeled	131
<i>IGH</i> FR3 - HEX	131
<i>IGH</i> FR3 - Unlabeled	131
<i>IGH</i> Framework 1 - 6FAM	131
<i>IGH</i> Framework 2 - 6FAM	131
<i>IGH</i> Framework 2 - Unlabeled	131
<i>IGH</i> Framework 3 - HEX	131
<i>IGH</i> Framework 3 - Unlabeled	131
<i>IGKV</i> - J - 6FAM	131
<i>IGKV</i> - J - Unlabeled	131
<i>IGKV</i> - <i>K<sub>de</sub></i> - 6FAM	131
<i>IGKV</i> - <i>K<sub>de</sub></i> - Unlabeled	131
<i>IGLV</i> - J - 6FAM	131
<i>PML/RAR<math>\alpha</math></i> , <i>MYL1-RAR<math>\alpha</math></i> - Unlabeled	131
<i>PML/RAR<math>\alpha</math></i> , <i>MYL2-RAR<math>\alpha</math></i> - Unlabeled	131
<i>PML/RAR<math>\alpha</math></i> , <i>PML3-RAR<math>\alpha</math></i> - Unlabeled	131
<i>TCRB</i> V - J1 +2 - 6FAM & HEX	131
<i>TCRB</i> V - J1 +2 - Unlabeled	131
<i>TCRB</i> V - J2 - 6FAM	131
<i>TCRB</i> V - J2 - Unlabeled	131
<i>TCRB</i> D - J1 +2 - 6FAM & HEX	131
<i>TCRB</i> D - J1 +2 - Unlabeled	131
<i>TCRD</i> V - D - J - 6FAM & HEX	131
<i>TCRG</i> V(1-8)J - HEX	131
<i>TCRG</i> V(1-8,9)J - 6FAM	131
<i>TCRG</i> V(1-8,10)J - 6FAM & HEX	131
<i>TCRG</i> V(1-8,10)J - Unlabeled	131
<i>TCRG</i> V(2-5,8-11)J1+2+P - 6FAM	131
<i>TCRG</i> V(9,11)J - 6FAM & HEX	131
<i>TCRG</i> V(9,11)J - Unlabeled	131

## B

<i>BCL1</i> / <i>JH</i> Translocation Assay	
Gel Detection	116
<i>BCL2</i> / <i>JH</i> t(14;18) Translocation Assay	
Gel Detection	118
<i>BCL2</i> / <i>JH</i> Translocation Assay	
Gel Detection	120
<i>BCR/ABL</i> RNA Dilution Sets	120
<i>BCR/ABL</i> t(9;22) Translocation Assay	
ABI Fluorescence Detection	122
Gel Detection	122

## C

Controls	133
Custom Products	
Companion Diagnostics	149
Custom Designed Assays	149
Custom Controls	149
Validation Panels	149

## D

DNA	
LymphoTrack® T-Cell Low Positive Control	138
LymphoTrack® T-Cell Internal Control	139
LymphoTrack® B-Cell Low Positive Control	138
LymphoTrack® B-Cell Internal Control	139
<i>FLT3</i> ITD Positive Control DNA	135
<i>FLT3</i> TKD Positive Control DNA	135
IVS-0000 Polyclonal Control DNA	134
IVS-0001 Clonal Control DNA	135
IVS-0004 Clonal Control DNA	135
IVS-0007 Clonal Control DNA	135
IVS-0008 Clonal Control DNA	136
IVS-0009 Clonal Control DNA	136
IVS-0010 Clonal Control DNA	136
IVS-0013 Clonal Control DNA	136
IVS-0019 Clonal Control DNA	136
IVS-0021 Clonal Control DNA	136
IVS-0024 Clonal Control DNA	136
IVS-0029 Clonal Control DNA	137
IVS-0030 Clonal Control DNA	137
IVS-0031 Clonal Control DNA	137
IVS-P002 Clonal Control DNA	137
<i>IGH</i> SMH Positive Control DNA	
Quick Reference for DNA Controls	134

## E,F,G,H,I

Enzymes	
EagleTaq DNA Polymerase	147
Identiclone® <i>BCL1</i> / <i>JH</i> Translocation Assay	
Gel Detection	76
Identiclone® <i>BCL2</i> / <i>JH</i> Translocation Assay	
Gel Detection	78
Identiclone® <i>IGH</i> + <i>IGK</i> B-Cell Clonality Assays	
ABI Fluorescence Detection	59
Gel Detection	59
Identiclone® <i>IGH</i> Gene Clonality Assays	
ABI Fluorescence Detection	61
Gel Detection	61
Identiclone® <i>IGK</i> Gene Clonality Assays	
ABI Fluorescence Detection	63
Gel Detection	63
Identiclone® <i>IGL</i> Gene Clonality Assays	
ABI Fluorescence Detection	65
Gel Detection	65
Identiclone® <i>TCRB</i> + <i>TCRG</i> T-Cell Clonality Assays	
ABI Fluorescence Detection	67
Gel Detection	67
Identiclone® <i>TCRB</i> Gene Clonality Assays	
ABI Fluorescence Detection	69
Gel Detection	69
Identiclone® <i>TCRD</i> Gene Clonality Assays	
ABI Fluorescence Detection	75
Gel Detection	75
Identiclone® <i>TCRG</i> Gene Clonality Assays	
ABI Fluorescence Detection	73
Gel Detection	73

**A**

ABI Fluorescence Detection Reagents	
HI-Deionized Formamide with ROX Size Standard (ABI 310)	147
HI-Deionized Formamide with ROX Size Standard (ABI 3100)	147
Amplification Control Master Mix	
Amplification Control Master Mix - 6FAM	146
Amplification Control Master Mix - Unlabeled	146
Analyte Specific Reagents	
<i>BCL2/JH</i> 3'Mbr - Unlabeled	131
<i>BCL2/JH</i> Mbr - Unlabeled	131
<i>BCL2/JH</i> mcr - Unlabeled	131
<i>BCR/ABL</i> b2.1-a3.1 - Unlabeled	131
<i>BCR/ABL</i> b2.2-a2.2 - 6FAM	131
<i>BCR/ABL</i> b2.2-a3.2 - 6FAM	131
<i>BCR/ABL</i> e1.1-a3.1 - Unlabeled	131
<i>BCR/ABL</i> e1.2-a2.2 - HEX	131
<i>BCR/ABL</i> e1.2-a3.2 - HEX	131
<i>BCR/ABL</i> b3.2-a3.2 - 6FAM	131
<i>IGH</i> DH1 - 6 - HEX	131
<i>IGH</i> DH7 - 6FAM	131
<i>IGH</i> FR1 - 6FAM	131
<i>IGH</i> FR1 - Unlabeled	131
<i>IGH</i> FR2 - 6FAM	131
<i>IGH</i> FR2 - Unlabeled	131
<i>IGH</i> FR3 - HEX	131
<i>IGH</i> FR3 - Unlabeled	131
<i>IGH</i> Framework 1 - 6FAM	131
<i>IGH</i> Framework 2 - 6FAM	131
<i>IGH</i> Framework 2 - Unlabeled	131
<i>IGH</i> Framework 3 - HEX	131
<i>IGH</i> Framework 3 - Unlabeled	131
<i>IGKV</i> - J - 6FAM	131
<i>IGKV</i> - J - Unlabeled	131
<i>IGKV</i> - <i>K<sub>de</sub></i> - 6FAM	131
<i>IGKV</i> - <i>K<sub>de</sub></i> - Unlabeled	131
<i>IGLV</i> - J - 6FAM	131
<i>PML/RAR<math>\alpha</math></i> , MYL1-RAR $\alpha$ - Unlabeled	131
<i>PML/RAR<math>\alpha</math></i> , MYL2-RAR $\alpha$ - Unlabeled	131
<i>PML/RAR<math>\alpha</math></i> , PML3-RAR $\alpha$ - Unlabeled	131
<i>TCRB</i> V - J1 +2 - 6FAM & HEX	131
<i>TCRB</i> V - J1 +2 - Unlabeled	131
<i>TCRB</i> V - J2 - 6FAM	131
<i>TCRB</i> V - J2 - Unlabeled	131
<i>TCRB</i> D - J1 +2 - 6FAM & HEX	131
<i>TCRB</i> D - J1 +2 - Unlabeled	131
<i>TCRD</i> V - D - J - 6FAM & HEX	131
<i>TCRG</i> V(1-8)J - HEX	131
<i>TCRG</i> V(1-8,9)J - 6FAM	131
<i>TCRG</i> V(1-8,10)J - 6FAM & HEX	131
<i>TCRG</i> V(1-8,10)J - Unlabeled	131
<i>TCRG</i> V(2-5,8-11)J1+2+P - 6FAM	131
<i>TCRG</i> V(9,11)J - 6FAM & HEX	131
<i>TCRG</i> V(9,11)J - Unlabeled	131

**B**

<i>BCL1/JH</i> Translocation Assay	
Gel Detection	116
<i>BCL2/JH</i> t(14;18) Translocation Assay	
Gel Detection	118
<i>BCL2/JH</i> Translocation Assay	
Gel Detection	120
<i>BCR/ABL</i> RNA Dilution Sets	
	120
<i>BCR/ABL</i> t(9;22) Translocation Assay	
ABI Fluorescence Detection	122
Gel Detection	122

**C**

Controls	133
Custom Products	
Companion Diagnostics	149
Custom Designed Assays	149
Custom Controls	149
Validation Panels	149

**D**

DNA	
LymphoTrack® T-Cell Low Positive Control	138
LymphoTrack® T-Cell Internal Control	139
LymphoTrack® B-Cell Low Positive Control	138
LymphoTrack® B-Cell Internal Control	139
<i>FLT3</i> ITD Positive Control DNA	135
<i>FLT3</i> TKD Positive Control DNA	135
IVS-0000 Polyclonal Control DNA	134
IVS-0001 Clonal Control DNA	135
IVS-0004 Clonal Control DNA	135
IVS-0007 Clonal Control DNA	135
IVS-0008 Clonal Control DNA	136
IVS-0009 Clonal Control DNA	136
IVS-0010 Clonal Control DNA	136
IVS-0013 Clonal Control DNA	136
IVS-0019 Clonal Control DNA	136
IVS-0021 Clonal Control DNA	136
IVS-0024 Clonal Control DNA	136
IVS-0029 Clonal Control DNA	137
IVS-0030 Clonal Control DNA	137
IVS-0031 Clonal Control DNA	137
IVS-P002 Clonal Control DNA	137
<i>IGH</i> SMH Positive Control DNA	
Quick Reference for DNA Controls	134

**E,F,G,H,I**

Enzymes	
EagleTaq DNA Polymerase	147
Identclone® <i>BCL1/JH</i> Translocation Assay	
Gel Detection	.76
Identclone® <i>BCL2/JH</i> Translocation Assay	
Gel Detection	.78
Identclone® <i>IGH</i> + <i>IGK</i> B-Cell Clonality Assays	
ABI Fluorescence Detection	.59
Gel Detection	.59
Identclone® <i>IGH</i> Gene Clonality Assays	
ABI Fluorescence Detection	.61
Gel Detection	.61
Identclone® <i>IGK</i> Gene Clonality Assays	
ABI Fluorescence Detection	.63
Gel Detection	.63
Identclone® <i>IGL</i> Gene Clonality Assays	
ABI Fluorescence Detection	.65
Gel Detection	.65
Identclone® <i>TCRB</i> + <i>TCRG</i> T-Cell Clonality Assays	
ABI Fluorescence Detection	.67
Gel Detection	.67
Identclone® <i>TCRB</i> Gene Clonality Assays	
ABI Fluorescence Detection	.69
Gel Detection	.69
Identclone® <i>TCRD</i> Gene Clonality Assays	
ABI Fluorescence Detection	.75
Gel Detection	.75
Identclone® <i>TCRG</i> Gene Clonality Assays	
ABI Fluorescence Detection	.73
Gel Detection	.73

# Notes

---

---

---

---

---

---

---

---

## Warranty and Liability Limits

Invivoscribe, Inc (Invivoscribe®) is committed to providing the highest quality products. Invivoscribe® warrants that the products meet or exceed the performance standards described in the Instructions For Use, as to products with such an insert. If a product is covered by product specifications and does not perform as specified, our policy is to replace the product or credit the full purchase price. No other warranties of any kind, expressed or implied, are provided by Invivoscribe®. Invivoscribe® liability shall not exceed the purchase price of the product. Invivoscribe® shall have no liability for direct, indirect, consequential or incidental damages arising from the use, results of use, or inability to use its products; product efficacy under purchaser controlled conditions in purchaser's laboratory must be established and continually monitored through purchaser defined and controlled processes including but not limited to testing of positive, negative, and blank controls every time a sample is tested. Ordering, acceptance and use of product constitutes purchaser acceptance of sole responsibility for assuring product efficacy and purchaser agreement to the limitation of liability set forth in this paragraph.

## Intended Uses

Research Use Only products have not been approved by any regulatory agency for clinical use and are not for diagnostic or therapeutic use. Our CE-marked IdentiClone™ assays, sold in Europe and not for sale or use in the United States, are *in vitro* Diagnostic devices intended for detection of clonal gene rearrangements and translocations for patients with suspected lymphoproliferations.

## Patent Notice

Many of the products described herein are covered by one or more of the following: European Patent Number 1549764, European Patent Number 2418287, European Patent Number 2460889, Japanese Patent Number 4708029, United States Patent No. 7,785,783, United States Patent 8859748, United States Patent 10280462, additional United States Patents Pending and planned future applications. All of these patents and applications are licensed exclusively to Invivoscribe®. Additional patents licensed to Invivoscribe covering some of these products apply elsewhere, or as described in this catalog.

Use of these products may require nucleic acid amplification methods such as Polymerase Chain Reaction (PCR). Any necessary license to practice amplification methods or to use amplification enzymes or equipment covered by third party patents is the responsibility of the user and no such license is granted by Invivoscribe®, expressly or by implication.

## Notice

©2020 Invivoscribe, Inc. All rights reserved. The trademarks mentioned herein are the property of Invivoscribe®, and/or its affiliates, or (as to the trademarks of others used herein) their respective owners.

- ILLUMINA® and MISEQ® are registered trademarks of Illumina, Inc.
- THERMO FISHER SCIENTIFIC® and ION PGM™ and ION S5™ are trademarks of Thermo Fisher Scientific or its subsidiaries.
- AGILENT® and BIOANALYZER® are registered trademarks of Agilent Technologies, Inc.
- KAPATM is a trademark of Kapa Biosystems.
- PERKIN ELMER® and LABCHIP® are registered trademark of Perkin Elmer.
- MICROSOFT®, WINDOWS®, and EXCEL® are registered trademarks of Microsoft Corporation.
- Roche® is a registered trademark of F. Hoffmann–La Roche Ltd.



## 2020 PRODUCT CATALOG

25TH ANNIVERSARY EDITION



©2020 Invivoscribe, Inc. All Rights Reserved.

Distributed by Abacus dx

1800 ABACUS (AUS) 0800 222 170 (NZ) | [info@abacusdx.com](mailto:info@abacusdx.com) | [www.abacusdx.com](http://www.abacusdx.com)

abacus dx